

# INVESTIGATING OFFICER'S CRASH REPORTING GUIDE



IOWA DEPARTMENT OF TRANSPORTATION  
**MOTOR VEHICLE DIVISION**

REVISED: MARCH 2024

# Table of contents

<a href="#">Why Do We Investigate and Fill Out Crash Reports?</a> .....	3	<a href="#">Appendix A: Manner of Crash/Collision Examples</a> .....	94
<a href="#">Motor Vehicle Crash Data Cycle</a> .....	4	<a href="#">Code 1: Non-Collision</a> .....	94
<a href="#">Investigating Officer’s Report of Motor Vehicle Crash Form</a> .....	5	<a href="#">Code 2: Head-On</a> .....	95
<a href="#">Composition of the 2019 Paper Crash Form</a> .....	5	<a href="#">Code 3: Rear-End</a> .....	95
<a href="#">Header Shown on Page 1 and 3</a> .....	6	<a href="#">Code 4: Angle, Oncoming Left Turn</a> .....	96
<a href="#">"Unit 1" and "Unit 2" (page 1 and 2)</a> .....	6	<a href="#">Code 5: Broadside</a> .....	96
<a href="#">Driver’s Information Section</a> .....	7	<a href="#">Code 6: Sideswipe, Same Direction</a> .....	97
<a href="#">Owner Section</a> .....	11	<a href="#">Code 7: Sideswipe, Opposite Direction</a> .....	97
<a href="#">Motor Vehicle Unit Codes Section</a> .....	16	<a href="#">Code 8: Rear to Rear</a> .....	98
<a href="#">Commercial Motor Vehicle Section</a> .....	41	<a href="#">Code 9: Rear to Side</a> .....	98
<a href="#">Injury Section</a> .....	48	<a href="#">Appendix B: FAQ</a> .....	99
<a href="#">Location Section</a> .....	57	<a href="#">When is a Unit Turning and When is it Changing Lanes?</a> .....	99
<a href="#">Accident Environment Section</a> .....	59	<a href="#">Is a Trailer a Unit?</a> .....	100
<a href="#">Roadway Characteristics Section</a> .....	64	<a href="#">How do I Report an Unoccupied Runaway Vehicle?</a> .....	100
<a href="#">First Harmful Event/Work Zone-Related Section</a> .....	69	<a href="#">How do I Report a Runaway Tire Striking Another Vehicle?</a> .....	101
<a href="#">Non-Motorist Section</a> .....	72	<a href="#">Improper Use of Event Code 33</a> .....	101
<a href="#">Property Damage Section</a> .....	81	<a href="#">How do I Report a Hit and Run Crash When I Know Nothing About the Striking Vehicle?</a> .....	102
<a href="#">Witness Section</a> .....	82	<a href="#">When the Correct Manner of Crash Doesn’t Make Sense</a> .....	102
<a href="#">Secondary Crash Section</a> .....	83	<a href="#">How do I Report on Crash Involving Trains?</a> .....	103
<a href="#">Officer Section</a> .....	84	<a href="#">Crash Was on Private Property, Should I Report It?</a> .....	103
<a href="#">Diagram Section</a> .....	85	<a href="#">Appendix C: National Crime Information Center Approved Abbreviations</a> .....	104
<a href="#">Narrative Section</a> .....	86	<a href="#">Appendix D: Color Code</a> .....	105
<a href="#">Intersection Definitions</a> .....	87	<a href="#">Appendix E: Officer in the Line of Duty Form</a> .....	106
<a href="#">State and U.S. Territory Abbreviations</a> .....	88	<a href="#">Appendix F: Work Zone Area</a> .....	107
<a href="#">Iowa Counties and Their Numbers</a> .....	89	<a href="#">Appendix G: Light Conditions</a> .....	108
<a href="#">Code Sheet</a> .....	90	<a href="#">Appendix H: Seating Positions</a> .....	109
		<a href="#">Appendix I: Sequence of Events</a> .....	110
		<a href="#">Appendix J: Air Bags Diagram</a> .....	113
		<a href="#">Appendix K: Clockpoint Diagrams for Different Types of Motor Vehicles</a> .....	114
		<a href="#">Appendix L: Diagram of an Interchange</a> .....	115
		<a href="#">Appendix M: Commercial Motor Vehicle Information</a> .....	116
		<a href="#">Appendix N: Sequence of Events</a> .....	120
		<a href="#">Test Your Crash Knowledge</a> .....	122
		<a href="#">Index</a> .....	124

# Why do we investigate and fill out crash reports?

Investigating and reporting motor vehicle crashes is a necessary law enforcement officer duty. Reports are intended to help reduce the number of crashes, deaths, and injuries through the collection of data elements and studying the data on how crashes occur. You play a vital role in the collection of this data and you must understand each piece of information that you enter.

Every reported crash must be promptly investigated, and every reasonable effort made to obtain accurate information for the completion of the report. If this is not possible, law enforcement shall use their best judgment and record their considered opinions based on their investigation and experience. Crash prevention programs and successful prosecutions in court are both dependent upon thorough crash investigation and report writing. Because crash reports may be viewed by lawyers, judges, and insurance companies, the quality of the report is crucial. The location of the crash, road condition at the time of the crash, and other evidence at the scene cannot be recreated unless the officer during the initial investigation documents these events.

Compliance with instructions in this manual will help ensure that reports are filled out completely, accurately, uniformly, and will be of the greatest possible value for crash prevention purposes.

The biggest misconception about crash reports is that they are for insurance companies. Yes, the Iowa Traffic Crash Report is used by insurance companies; however, data reported on the form is also used by many others, including those listed below.

- The Iowa Department of Transportation (Iowa DOT) to update driver records and get problem drivers off our roads and enforcement of Iowa's financial responsibility law.
- City, county, and state traffic engineers to help redesign and upgrade roads and intersections.
- Law enforcement agencies to assign patrols to roads where an unusually high number of crashes occur.
- Federal safety agencies that develop safety initiatives, implement safety programs, initiate vehicle recalls, and contribute to making and changing laws.
- Researchers studying different segments of the driving population or helping design safer vehicles.
- Other stakeholders who need quality data to develop policies and programs to improve the safety and operation on Iowa's transportation network.

Accurate and timely data is important to everyone. Officers need to send in their crash reports to the Iowa DOT within 24 hours after their investigation. Ideally an initial crash report should be sent in within five days of the crash.

Crashes result in an economic cost of increased insurance rates, increased medical expenses, loss of property, loss of life, and loss of personal income. They produce a drain on law enforcement in both time and money, and pose a personal risk to every driver, passenger, and pedestrian in Iowa.

By gaining more complete and accurate information about traffic crashes and creating a more complete crash database, unsafe roadways can be identified, problems can be mitigated, and the state can move toward our goal of zero fatalities.

The Iowa DOT extends a sincere thank-you to law enforcement agencies and officers performing this valuable duty for the citizens of Iowa.

# MOTOR VEHICLE CRASH DATA CYCLE

COOPERATION IS THE KEY TO SAFER IOWA ROADS AND STREETS

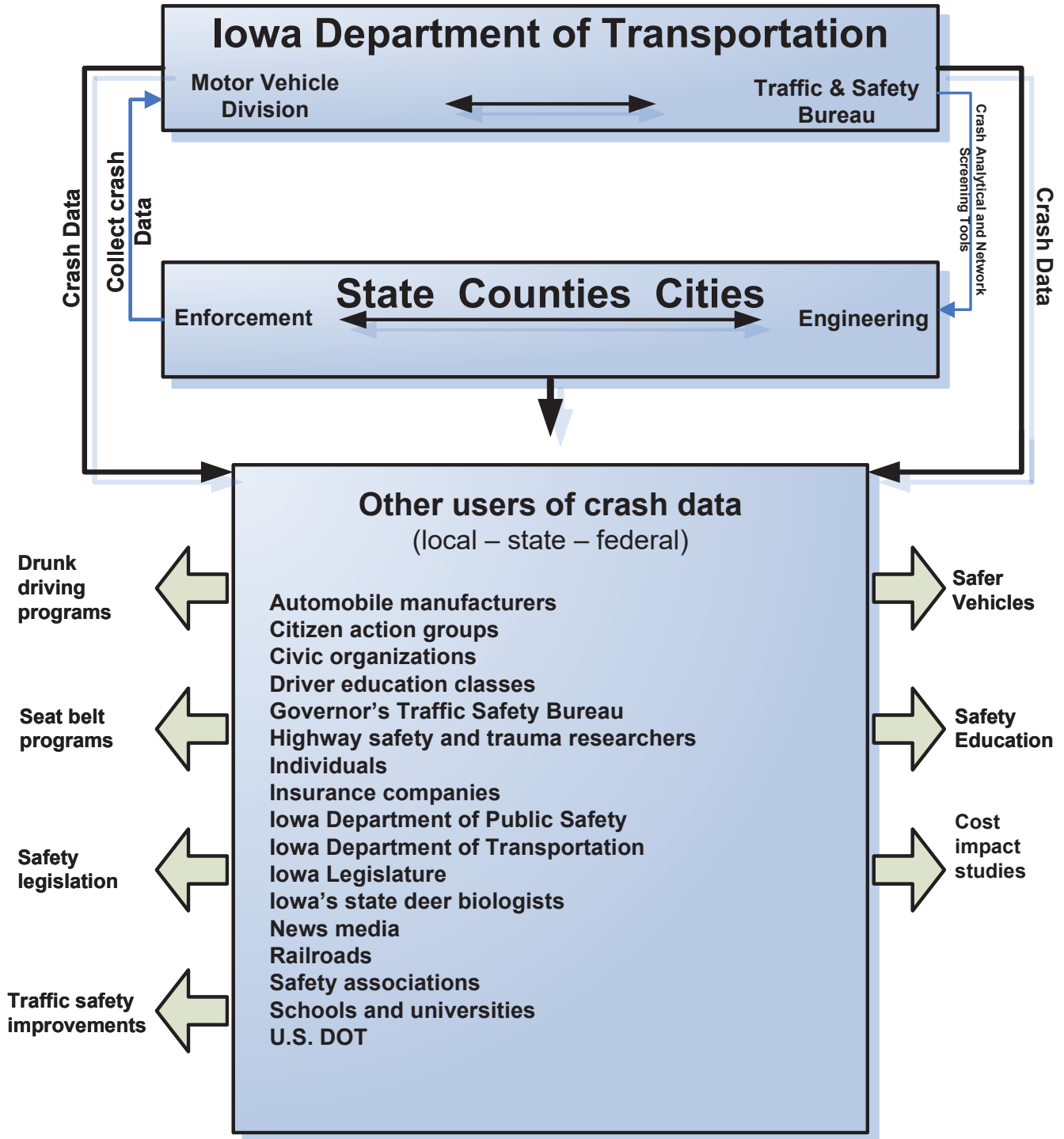

# INVESTIGATING OFFICER'S REPORT OF MOTOR VEHICLE CRASH FORM

This manual details how to complete the Investigating Officer's Report of Motor Vehicle Accident paper form. It is also applicable to Traffic and Criminal Software (TraCS ) because almost all of Iowa's crash reports are collected electronically using TraCS. This software package is available to all law enforcement agencies in Iowa to complete crash reports and transmit them to the Iowa DOT electronically. The crash report in TraCS is the Mobile Accident Reporting System (MARS) form. This guide will have some specific information for users of TraCS. Eventually this guide will be completely changed over to a TraCS-specific guide.

**WHAT IS A REPORTABLE CRASH?** A reportable crash is one in which all damages (vehicle and property) are combined and estimated to be \$1,500 or more, and/or an injury or fatality has occurred anywhere in the state of Iowa. This **would** include crashes that occur on private property.

## COMPOSITION OF THE 2019 PAPER CRASH FORM

---

The 2019 Investigating Officer's Report of Motor Vehicle Accident has a total of four pages (two sheets front and back).

- **Page 1** is for collecting all information about the motor vehicle labeled "Unit 1"; including driver, owner, commercial vehicle information, occupant safety restraint use, and injuries that occurred in this unit only.
- **Page 2** is for collecting all information about the motor vehicle labeled "Unit 2," if a second motor vehicle was involved in the crash.
- **Page 3** is for the information for location of crash, crash environment, roadway characteristics, first harmful event, and work zone related activity, followed by the "**Non-motorist**" section, non-motor vehicle property damage, witness information, secondary crash information, and officer information.
- **Page 4** finishes off the report with an area for a diagram and a narrative of the crash.

For crashes involving more than 2 units, it will require taking another packet and marking "unit 1" as "unit 3" and "unit 2" as "unit 4," as well as changing the page number.

In TraCS, you just need to add additional Units, Witnesses, Property Damage, or Injured Persons as needed.

Instructions on how to complete the report begin on the next page.



## HEADER SHOWN ON PAGE 1 AND PAGE 3



### INVESTIGATING OFFICER'S REPORT OF MOTOR VEHICLE ACCIDENT

Sheet 1 of 4

Law Enforcement Case Number:

5

MAIL REPORTS TO: Iowa Department of Transportation, Driver & Identification Services, P.O. Box 9204, Des Moines, Iowa 50306-9204

Date of Accident 1

Time of Accident 2

County 3

Accident occurred within corporate limits of (city): 4

### 1 & 2 CRASH DATE AND TIME

**DEFINITION:** The date (month, day and year) and time (00:00-23:59 military time) at which the crash occurred. Midnight is designated as 00:00 and is considered the start of a new day. If the date and time are not known, (usually a hit & run) use the date and time that the damage was first discovered.

**RATIONALE:** Important for management/administration, evaluation, and linkage.

### 3 COUNTY

**DEFINITION:** The county in which the crash physically occurred. (For a list of Iowa counties see [page 89](#).)

**RATIONALE:** Important for analyses of state and county area programs. Critical for linkage of the crash file to other state data files.

### 4 ACCIDENT OCCURRED WITHIN CORPORATE LIMITS OF (CITY)

**DEFINITION:** If the crash occurred within corporate limits of city, enter the name of the city.

**RATIONALE:** Important for analyses of state and county area programs. Critical for linkage of the crash file to other state data files.

### 5 LAW ENFORCEMENT CASE NUMBER

**DEFINITION:** Enter a unique case number defined by your agency in the "Law Enforcement Case Number" field that will identify this crash.

**RATIONALE:** Used to document a specific crash. If this identifier is available at the scene, it can also be recorded on the Emergency Medical Services (EMS) record for linkage purposes. Enables subfiles to be created for analyses and linked back to the crash data file.

## "UNIT 1" AND "UNIT 2" (PAGES 1 AND 2)

**DEFINITION:** A unit is any single **motor** vehicle (i.e., car, truck, semi, agricultural tractor, motorcycle, or other vehicle with an engine) or the combination of a power unit and a trailer. **Non-motorists** such as pedestrians, bicyclists, and horse and buggy occupants should not be entered as units (refer to the "Non-motorist" section on [page 72](#)). The first page of your report consists of all information pertaining to "Unit 1," and page 2 will consist of the second unit involved in the crash. If you need to add more units, use additional packets.

For each unit, start with completing the "Driver Information." Fields 1 through 14 relate directly to the driver that was physically operating the power unit of the vehicle involved.

Driver's Last Name <b>1</b>				First Name <b>1</b>				Middle Name <b>1</b>	
Address <b>2</b>						City <b>2</b>		State <b>2</b>	ZIP Code <b>2</b>
Date of Birth <b>3</b>		Driver License Number <b>5</b>			CDL	Citation Charge:			
Male <input type="radio"/>	Female <input type="radio"/>	State <b>7</b>	Class <b>8</b>	Endorsements <b>9</b>	Restrictions <b>10</b>	Yes <input type="radio"/>	No <input checked="" type="radio"/>	1. <b>11</b>	3.
								2.	4.
Alcohol Test Given: <b>12</b>		Test Results: <b>12</b>		Drug Test Given: <b>13</b>		Test Result: <b>13</b>		Re-exam: Yes <input type="radio"/>	No <input checked="" type="radio"/>
								Reason for Re-Exam Request: <b>14</b>	

## DRIVER'S INFORMATION

- If the vehicle is parked, skip to the “**Owner**” section.
- For crashes where the driver is unknown, leave the driver’s name field blank and skip to the “**Owner**” section.
- If the vehicle was disabled from a previous crash, two reports must be completed because these are two separate incidents.

In TraCS, if the “**Vehicle Action**” is a code 12 “**Legally parked**” or code 13 “**Illegally parked/unattended**,” the driver’s information will be grayed out. This is done to avoid having a person listed as a driver when the vehicle was not being actively driven at the time of the crash. Owner’s and insurance information is still gathered in these cases, but no one may be listed as the driver of a parked car.

### 1 DRIVER'S NAME

**DEFINITION:** The full name of the individual involved in the crash.

**RATIONALE:** This data element should be collected to facilitate linkage when names are available to health and insurance files and to corroborate the driver’s license number of drivers. This is required to meet Iowa’s financial responsibility laws and enables sanctions to be created when appropriate.

Clearly enter the “**Driver’s Last Name**,” “**First Name**,” and “**Middle Name**” with the last, first, and middle names **exactly** as it appears on the driver’s license.

### 2 DRIVER'S ADDRESS

**DEFINITION:** Current residence address of the driver

**RATIONALE:** Used to submit request for insurance information or to mail out sanction notices.

Enter the driver’s complete “**Address**,” “**City**,” “**State**,” and “**ZIP Code**.” If the driver is from a foreign country, a location other than one of the 50 U.S. states, U.S. territories, Canada, or Mexico, enter the name of the country in the “**State**” field. (If the address has changed, enter the new address and note the old in the “**Narrative**” section. Mark at the top of the form to “**See Narrative.**”) Advise the individual to notify the Iowa DOT of their new address if they are an Iowa resident.

### 3 DRIVER'S DATE OF BIRTH

**DEFINITION:** The date of birth of the person driving the vehicle using the MM/DD/YYYY format.

**RATIONALE:** Accurate reporting of date of birth is used to assess the effectiveness of occupant protection systems for specific age groups and to identify the need for safety programs directed toward them. This element is also critical in providing linkage between the crash, emergency medical services, and hospital records.

Enter the MM/DD/YYYY information in the driver’s “**Date of Birth**” field. When entering driver’s information, investigators should record the date of birth exactly as it appears on the driver’s license. Discrepancies in the driver’s date of birth should be explained in the narrative.

### 4 DRIVER'S GENDER

**DEFINITION:** The gender of the person involved in the crash.

**RATIONALE:** Used to evaluate the effect of gender of the person involved on occupant protection systems and motor vehicle design characteristics.

Indicate whether individual is a male or female.

Driver's Last Name <b>1</b>				First Name <b>1</b>				Middle Name <b>1</b>	
Address <b>2</b>						City <b>2</b>		State <b>2</b>	ZIP Code <b>2</b>
Date of Birth <b>3</b>		Driver License Number <b>5</b>			CDL Yes No <b>6</b>		Citation Charge: <b>11</b>		
Male <input type="radio"/>	Female <input type="radio"/>	State <b>7</b>	Class <b>8</b>	Endorsements <b>9</b>	Restrictions <b>10</b>	1.		3.	
						2.		4.	
Alcohol Test Given: <b>12</b>		Test Results: <b>12</b>		Drug Test Given: <b>13</b>		Test Result: <b>13</b>		Re-exam: Yes No <b>14</b>	
								Reason for Re-Exam Request: <b>14</b>	

## 5 DRIVER'S LICENSE NUMBER

**DEFINITION:** A unique set of alphanumeric characters assigned by the authorizing entity issuing a driver's license to the individual.

**RATIONALE:** This element is critical to providing linkage between crash and driver's license files at the state level.

- Use the unique alphanumeric identifier assigned by the official licensing authority of the state, commonwealth, foreign country, U.S. government, Indian nation, etc. Enter the information in the "Driver License Number" field **exactly** as it appears on the driver's license. Even if a person's license is suspended, revoked, or expired, the number should be entered here. If the driver has not been issued a license, enter "None" in this field unless the Iowa DOT has issued an assigned customer number. Here's an example: If the driver's license number is **C123456**, include the "C" in front of the number in the "Driver License Number" field. Put "IA" in the "State" field. In TraCS leave the DL# blank if the driver does not have a Driver's License.
- Investigating officers are encouraged to conduct a computer check on all drivers involved in a crash to ascertain the validity of their driver's license. If the license is determined to be invalid for any reason, officers are further encouraged to take appropriate enforcement action.

## 6 COMMERCIAL DRIVER'S LICENSE (CDL)

**DEFINITION:** This indicates that the license is a commercial driver's license.

**RATIONALE:** This information is mandated by the Federal Motor Carrier Safety Administration for commercial drivers. It is critical to providing linkage between crash and driver's license files at the state level. This information is important to separate the noncommercial licenses included by some states in Class C with the commercial licenses.

Indicate yes or no.

## 7 DRIVER'S LICENSE STATE

**DEFINITION:** The geographic or political entity issuing a driver's license, which includes the United States, the District of Columbia, and outlying areas; Indian nations, U.S. government, Canadian provinces, and Mexican states (including the Distrito Federal), as well as other jurisdictions.

**RATIONALE:** Necessary to evaluate the effectiveness of various licensing laws. This element is also critical in providing linkage between the crash and driver's license files at the state level.

Enter the standardized two-digit abbreviation for the state or country in which the driver is legally licensed. Refer to [page 88](#) for a listing of two letter state/country designations. If the driver is not licensed to drive a vehicle in any state or country, leave this data blank and write "None" in the "Driver License Number" field unless there is an assigned Iowa DOT customer number, then use "IA" to show Iowa issued this customer number. In TraCS, if the driver does not have a driver's license, select "NO" from the list for None.

## 8 CLASS

**DEFINITION:** This indicates the type of driver's license issued by the state and the type of motor vehicle the driver is qualified to drive.

**RATIONALE:** This information is mandated by the FMCSA for commercial drivers. This element is critical to providing linkage between the crash and driver's license files at the state level.

List the class as shown on the license.

## 9 ENDORSEMENTS

**DEFINITION:** Any provisions to the driver's license, both commercial and noncommercial.

**RATIONALE:** This information is mandated by the Federal Motor Carrier Safety Administration (FMCSA) for commercial drivers. This element is critical to providing linkage between the crash and driver's license files at the state level.

List the endorsement codes (not labels) exactly as shown on the license. Do not separate with commas or any other punctuation.

## 10 RESTRICTIONS

**DEFINITION:** Limitations assigned to an individual's driver's license by the license examiner.

**RATIONALE:** Used to identify if a driver involved in a crash has limitations on their driver's license that may have pertained to or led to the crash.

List the restriction codes (not labels) exactly as shown on the license. Do not separate with commas or any other punctuation.



Driver's Last Name <b>1</b>				First Name <b>1</b>				Middle Name <b>1</b>			
Address <b>2</b>						City <b>2</b>			State <b>2</b>	ZIP Code <b>2</b>	
Date of Birth <b>3</b>		Driver License Number <b>5</b>			CDL Yes No	Citation Charge: 1. <b>11</b>			3.		
Male <input type="radio"/>	Female <input type="radio"/>	State <b>7</b>	Class <b>8</b>	Endorsements <b>9</b>	Restrictions <b>10</b>	<input type="radio"/> 6 <input type="radio"/>	2.			4.	
Alcohol Test Given: <b>12</b>		Test Results: <b>12</b>		Drug Test Given: <b>13</b>		Test Result: <b>13</b>		Re-exam: Yes No <input type="radio"/> 14 <input type="radio"/>		Reason for Re-Exam Request: <b>14</b>	

### 11 CITATION CHARGE

**DEFINITION:** All motor vehicle-related violation codes, if any, that apply to this driver.

**RATIONALE:** Important for evaluation of safety laws and enforcement practices.

If a charge related to the crash is filed against a driver, enter the code number and abbreviated text in the “Citation Charge” field. For example: 321.277 – reckless driving. If more space is needed, add the additional charges to the narrative.

### 12 ALCOHOL TEST INFORMATION

**DEFINITION:** Indication of the presence of alcohol by test, type, and result.

**RATIONALE:** Alcohol remains the most prevalent drug involved in motor vehicle crashes. Capturing alcohol concentration whenever a driver or non-motorist is tested will provide an accurate assessment of the role of alcohol involvement. The type of test used to obtain the alcohol concentration also is important information to collect.

- a. “Alcohol Test Given” refers to a blood, breath, urine, or vitreous (fluid surrounding the eye) test that has been taken.

- Code 1** None (test not requested)
- Code 2** Blood
- Code 3** Urine
- Code 4** Breath
- Code 5** Vitreous
- Code 9** Refused (test requested but the driver refused to take the test)

- b. If the test result is known before the crash report is submitted to the Iowa DOT’s Office of Driver Services, enter the result under “Test Results.” If the test result is not available when the crash report is submitted, send the results later using a copy of the officer’s report you submitted earlier to the Iowa DOT and at the end of the “Narrative” leave blank line and then type in that “Test Results” were added.

- c. If any test was given and it was under the legal limit, still enter this information with the results.
- d. If you have indicated under “Driver Condition” that the driver was impaired and yet you have not indicated a test, indicate in the narrative the reason that they were impaired yet not tested.

### 13 DRUG TEST INFORMATION

**DEFINITION:** Indication of the administered drug test, type, and result. Excludes drugs administered post-crash.

**RATIONALE:** Identifying drug-related crashes helps develop and evaluate programs directed at reducing drug- and alcohol-related crashes. Whenever evidence of drug use is available, it should be captured.

“Drug Test Given” refers to the type of test that has been taken.

- Code 1** None (test not requested)
- Code 2** Blood
- Code 3** Urine
- Code 5** Vitreous
- Code 9** Refused (test requested but the driver refused to take the test)

“Drug Test Results” can fall into one of the below categories.

If the test is known before the crash report is submitted to the Iowa DOT’s Office of Driver Services, indicate what type of drug was present. If the test result is not available when the crash report is submitted, send the result when available.

- Code 01** Negative – when it has been determined that none was present.
- Code 02** Cannabis – when marijuana is present.

Driver's Last Name <b>1</b>				First Name <b>1</b>				Middle Name <b>1</b>						
Address <b>2</b>						City <b>2</b>				State <b>2</b>		ZIP Code <b>2</b>		
Date of Birth <b>3</b>			Driver License Number <b>5</b>					CDL Yes No		Citation Charge: 1. <b>11</b> 3.				
Male <input type="radio"/> <b>4</b>		Female <input type="radio"/> <b>4</b>		State <b>7</b>		Class <b>8</b>		Endorsements <b>9</b>		Restrictions <b>10</b>		2. <b>6</b> 4.		
Alcohol Test Given: <b>12</b>			Test Results: <b>12</b>			Drug Test Given: <b>13</b>			Test Result: <b>13</b>		Re-exam: Yes No <b>14</b>		Reason for Re-Exam Request: <b>14</b>	

**Code 03**

**Central nervous system depressants** – when it has been determined that drugs are present that are sometimes referred to as sedatives and tranquilizers, which are substances that can slow brain activity. Some of the common types are Benzodiazepines (Valium, Xanax), non-Benzodiazepine (Ambien, Lunesta, Sonata), Barbiturates (Mebaral, Nembutal). Used when the person is not prescribed these drugs.

**Code 04**

**Central nervous system stimulants** - when it has been determined that drugs are present that are sometimes referred to as speed or uppers, which are substances that can speed up brain activity. Some of the common types of CNS stimulants include Cocaine, "Crack", Amphetamines and Methamphetamine ("Crank"). Used when the person is not prescribed these drugs.

**Code 05**

**Hallucinogens** – when drugs are present that are used to modify people's perceptions, including LSD and Psilocybin (magic mushrooms).

**Code 06**

**Inhalants** – when ordinary household products are present that are inhaled or sniffed to get high.

**Code 07**

**Narcotic analgesics** – when drugs are present and the person is not prescribed the drugs used for relief of severe pain and includes Heroin, Morphine, and Codeine.

**Code 08**

**Dissociative anesthetic (PCP)** – when drugs used for general anesthetic are present.

**Code 09**

**Prescription drug** – when tested positive for a drug that has been prescribed to the individual.

**Code 98**

**Other (explain in the narrative field)**– when none of the above are applicable.

**14 RE-EXAM**

**DEFINITION:** This is a request for the driver's skills to be re-examined based on possible physical or mental impairment that the officer observed at the scene of the crash. A re-exam is not to be requested to punish the driver. You must be able to articulate a reason you think the driver should be re-examined.

**RATIONALE:** Expedite action taken against possible unsafe drivers.

Indicate whether you feel this person should be re-examined and give a brief description of why. You can use the "**Narrative**" field if you wish to give more information. You can also attach any other documentation you want to include with the report.

Owner's Last Name 1				First Name 1			Middle Name 1		
Address 2				City 2			State 2	ZIP Code 2	
License Plate No. 3	State: 4	Year: 4	VIN: 5		Color: 6	Year: 7	Make: 8	Model: 9	Style: 10
Trailer Plate No.: 11	State: 12	Year: 12	VIN: 13		Tow: 14	Tow #: 15	Towed to: 15	Approx. Cost to Repair or Replace 16	
Insurance Company Name: 17			Insurance Co. Phone Number: 17		Insurance Policy Number 17				

## OWNER SECTION

The “**Owner**” section of the Investigating Officer’s Crash Report details information concerning the owner of the vehicle, the vehicle information, as well as any vehicle, trailer, or object that is being towed by the power unit, and any insurance information related to this vehicle.

### 1 OWNER’S NAME

**DEFINITION:** The registered owner or owners of the main power unit, which could be a car, pickup, motorcycle, or a vehicle that could be considered a commercial vehicle such as a truck-tractor, etc. The power unit types are found on the code sheet under “**Vehicle Configuration.**”

**RATIONALE:** The actual owner’s information is used to meet the requirement of Iowa’s financial responsibility requirements and used to create sanctions, if needed. The vehicle information is used in various studies conducted on the safety of the vehicle and any improvements needed on a specific vehicle.

- a. Enter the “**Owner’s Last Name,**” “**First Name,**” and “**Middle Name**” exactly as it appears on the vehicle registration. If the vehicle is registered to a business firm or company, enter the company name in the “Owner’s Last Name” field and as it is shown on the registration.
- b. If there is more than one name on the registration, enter the name listed first on the registration.
- c. If the driver is the same as owner, it is acceptable to write “**Same as above.**” In TraCS you will be asked if the owner is the same as the driver and it will automatically fill in the same information.
- d. When there is a combination of vehicles, such as a car pulling a trailer or a semitrailer involved, enter the owner of the power unit only, which would be the car or the semi part of the semitrailer.
- e. Use the information that comes back on the registration check. If there is a discrepancy regarding ownership of the vehicle between the registration information and what the driver advises, please note that in the “**Narrative**” section.
- f. If a leased vehicle is involved in a crash, enter the name of the person or company to whom the vehicle is leased and not the name of the leasing company.
- g. To document the owner of a short-term rental vehicle, list the name of the rental company as shown on the rental agreement.

### 2 OWNER’S ADDRESS

**DEFINITION:** Current location where owner currently resides.

**RATIONALE:** Used to submit request for insurance information or to mail out sanction notices.

Enter the owner’s complete “**Address, City, State, and ZIP Code.**” If the owner is from a foreign country, a location other than one of the 50 U.S. States, U.S. Territories, Canada, or Mexico, enter the name of the country in the “**State**” field. (If the address has changed, enter the new address and note the old in the “**Narrative**” section. Mark at the top of the form to “**See Narrative.**”) Advise the individual to notify the Iowa DOT of their new address if they are an Iowa resident.

### 3 LICENSE PLATE NUMBER

**DEFINITION:** The alphanumeric identifier or other characters, exactly as displayed, on the registration plate or tag affixed to the motor vehicle. For combination trucks, the motor vehicle plate number is obtained from the power unit or tractor.

**RATIONALE:** Critical for linkage between the crash and motor vehicle registration files to access the motor vehicle identification number.

- a. Enter the entire license plate number, including all letters as it appears on the registration. Officers should verify the number on the registration to the number displayed on the license plate to ensure that the correct number is recorded.
- b. Entering the county name is not required.

Owner's Last Name 1				First Name 1				Middle Name 1				
Address 2						City 2			State 2	ZIP Code 2		
License Plate No. 3	State: 4	Year: 4	VIN: 5			Color: 6	Year: 7	Make: 8	Model: 9	Style: 10		
Trailer Plate No.: 11	State: 12	Year: 12	VIN: 13			Tow: 14	Tow #: 15	Towed to: 15	Approx. Cost to Repair or Replace 16			
Insurance Company Name: 17					Insurance Co. Phone Number: 17			Insurance Policy Number 17				

#### 4 LICENSE PLATE/STATE/YEAR

**DEFINITION:** The state, commonwealth, territory, Indian nation, U.S. government, foreign country, etc., issuing the registration plate and the year of registration as indicated on the license plate displayed on the motor vehicle. For foreign countries, the Model Minimum Uniform Crash Criteria (MMUCC) requires only the name of the country.

**RATIONALE:** This element is critical in providing linkage between the crash and motor vehicle registration files to access the motor vehicle identification number.

- Enter the state using the two-letter state abbreviations in the “**State**” field as shown [Appendix C on page 104](#).
- Enter the validation sticker year in the “**Year**” field in the “**License Plate No.**” section as this would be the most recent year of registration.

#### 5 VIN (MOTOR VEHICLE IDENTIFICATION NUMBER)

**DEFINITION:** A unique combination of alphanumeric characters assigned to a specific motor vehicle that is designated by the manufacturer.

**RATIONALE:** Important to identify specific motor vehicle design characteristics and occupant protection systems for effectiveness evaluations.

- This is a manufacturer-assigned number that is permanently affixed to the motor vehicle. You should attempt to verify the VIN listed on the registration against the VIN plate on the vehicle itself before entering it on the crash report.
- The VIN plate on most automobiles, pickup trucks, and vans is located on the front of the dashboard, in the front left corner, visible through the windshield.
- The VIN plate on most tractor-trailers is located on a plate in the passenger compartment. This plate can readily be seen by opening the driver’s door.
- The VIN plate on the majority of motorcycles is located on the fork or frame itself, not the number on the engine; most motorcycles have an engine serial number that is different from the VIN.
- Be sure to enter the full number in the “**VIN**” field.

#### 6 COLOR OF MOTOR VEHICLE

**DEFINITION:** The paint color of the vehicle driven.

**RATIONALE:** Used to ensure that the vehicle is the correct one that is shown in the registration files.

Enter the three-letter description in the “**Color**” field. Refer to [Appendix D on page 105](#) for color code description.

#### 7 YEAR OF MOTOR VEHICLE

**DEFINITION:** The year that is assigned to a motor vehicle by the manufacturer.

**RATIONALE:** Important for use in identifying motor vehicle model year for evaluation, research, and crash comparison purposes.

This information is found on the registration paperwork or can be obtained by running a registration check. You can enter the last two digits in the “**Year**” field by the make and model fields.

#### 8 MAKE OF MOTOR VEHICLE

**DEFINITION:** The distinctive name applied to a group of motor vehicles by a manufacturer.

**RATIONALE:** Important for use in identifying motor vehicle make, for evaluation, research, and crash comparison purposes.

Enter the manufacturer of the vehicle in the “**Make**” field. Some examples of make for passenger vehicle include Ford, Chrysler, Chevrolet, Toyota, etc. For trucks and buses some possible entries are Dodge, Ford, GMC, International, Freightliner, etc. For motorcycles, motorbikes, etc., appropriate entries would be Honda, HD (Harley-Davidson), Yamaha, etc. **Refer to [page 104](#) for more National Crime Information Center approved abbreviations.**

Owner's Last Name 1				First Name 1				Middle Name 1				
Address 2						City 2			State 2	ZIP Code 2		
License Plate No. 3		State: 4	Year: 4	VIN: 5			Color: 6	Year: 7	Make: 8	Model: 9	Style: 10	
Trailer Plate No.: 11		State: 12	Year: 12	VIN: 13			Tow: 14	Tow #: 15	Towed to: 15	Approx. Cost to Repair or Replace 16		
Insurance Company Name: 17				Insurance Co. Phone Number: 17				Insurance Policy Number 17				

### 9 MODEL OF MOTOR VEHICLE

**DEFINITION:** The manufacturer-assigned code denoting a family of motor vehicles (within a make) that have a degree of similarity in construction, such as body, chassis, etc.

**RATIONALE:** Important for use in identifying the motor vehicle model for evaluation, research, and crash comparison purposes.

Assigned by motor vehicle manufacturer and is obtained from the vehicle registration. Enter the manufacturer's model name such as Ram, F150, Impala, etc. On most pickup truck registrations the model is listed as 6000; however, this is not an acceptable model for this report. Officers should attempt to identify an appropriate model (pickups S-10, Sierra, Tundra, Ranger, etc.). If a model name cannot be located, then use an identifier such as "VAN, PK (pickup), SEMI," etc.



**SUV** - A full-size, multipurpose vehicle designed to have off-road capabilities. They are generally four-wheel drive and have a longer wheelbase with increased ground clearance. The vehicle includes a combined passenger and cargo area.



**Pickup** (use abbreviation PK)  
The vehicle has a cab for passengers and an open-top, rear cargo area. Larger and more powerful than a small pickup, they are able to carry larger loads.



**Minivan** (use abbreviation VAN)  
A small passenger van that is identifiable by an enclosed passenger/cargo area and a relatively short hood. They often have a sliding side door and a rear hatch door.

### 10 STYLE OF MOTOR VEHICLE

**DEFINITION:** The specific type of vehicle being driven based on the chassis attached to it (i.e., truck, van, bus, etc.).

**RATIONALE:** Important for identifying the vehicle for evaluation, research and crash comparison purposes.

*Some examples of vehicle styles:*



**Two-door auto** (use abbreviation 2D)  
A passenger car equipped with two doors for entrance/exit and a separate trunk area for cargo.



**Four-door auto** (use abbreviation 4D)  
A passenger car equipped with four doors for entrance/exit and a separate trunk area for cargo.



**Station wagon** (use abbreviation SW)  
A station wagon is a passenger car with an enlarged cargo area. This auto has one or more rows of folding or removable seats behind the driver. The cargo area in the rear of the auto is not permanently separated from the passenger compartment area.

### 11 TRAILER PLATE NUMBER

**DEFINITION:** The trailer or vehicle's plate number that is being towed by the power unit that is not a commercial vehicle (i.e., car pulling a boat trailer or one vehicle towing another vehicle).

**RATIONALE:** Used to identify the towed trailer or vehicle.

- a. Note that this should not include **semitrailers** or other vehicles that weight **over 10,001 pounds** as these would be located in the "**Commercial**" section.

### 12 TRAILER PLATE STATE/YEAR

**DEFINITION:** The state, commonwealth, territory, Indian nation, U.S. government, foreign country, etc., issuing the registration plate and the year of registration as indicated on the registration plate displayed on the trailer or towed vehicle. For foreign countries, MMUCC requires only the name of the country.

**RATIONALE:** This element is critical in providing linkage between the crash and motor vehicle registration files to access the motor vehicle identification number.

- a. Enter the state using the two-letter state abbreviations in the "**State**" field as shown on [page 88](#).
- b. Enter the validation sticker year in the "**Year**" field as this would be the most recent year of registration.



Owner's Last Name 1				First Name 1				Middle Name 1				
Address 2						City 2			State 2	ZIP Code 2		
License Plate No. 3	State: 4	Year: 4	VIN: 5			Color: 6	Year: 7	Make: 8	Model: 9	Style: 10		
Trailer Plate No.: 11	State: 12	Year: 12	VIN: 13			Tow: 14	Tow #: 15	Towed to: 15	Approx. Cost to Repair or Replace 16			
Insurance Company Name: 17					Insurance Co. Phone Number: 17			Insurance Policy Number 17				

### 13 TRAILER VIN

**DEFINITION:** A unique combination of alphanumeric characters assigned to a specific motor vehicle or trailer that is designated by the manufacturer.

**RATIONALE:** Important to identify specific motor vehicle design characteristics and occupant protection systems for effectiveness evaluations.

- This is a manufacturer-assigned number that is permanently affixed to the motor vehicle. You should attempt to verify the VIN listed on the registration against the VIN plate on the vehicle itself before entering it on the crash report.
- The VIN plate on most automobiles, pickup trucks, and vans is located on the front left corner of the dashboard and visible through the windshield.
- The VIN plate on most tractor-trailers is located on a plate in the passenger compartment. This plate can readily be seen by opening the driver's door.
- The VIN plate on the majority of motorcycles is located on the fork or frame itself, not the number on the engine; most motorcycles have an engine serial number that is different from the VIN.
- Be sure to enter the full number in the "VIN" field.
- If unable to locate a VIN for the trailer, write "Unknown" in the "VIN" field.

#### Code 1

**Driven away** – the vehicle was able to drive away on its own power even if it had just been pulled out of a ditch. There cannot be a code 4 or 5 in the "Extent of Damage" field.

#### Code 2

**Disabled, privately arranged** – the vehicle is not able to be driven safely from the scene of the crash and the driver or owner is making their own arrangements to have it towed. There cannot be a code 1, 2, or 3 in the "Extent of Damage" field.

#### Code 3

**Disabled, officer arranged** – the vehicle is not able to be driven safely from the scene and the officer is making the arrangements to have it towed. Should not be used because of an arrest and there cannot be a code 1, 2, or 3 in the "Extent of Damage" field.

#### Code 4

**Not disabled, privately arranged** – the vehicle can be driven away safely; however, the driver or owner is electing for whatever reason to have it privately towed. There cannot be a code 4 or 5 in the "Extent of Damage" field.

#### Code 5

**Not disabled, officer arranged** – the vehicle can be driven away safely; however, the driver or owner is electing for whatever reason to have it towed and the officer is making the arrangements. This will also cover when the officer is having the vehicle towed away because they have arrested the individual or the individual has been transported to the hospital. There cannot be a code 4 or 5 in the "Extent of Damage" field.

#### Code 6

**Abandoned/Left at scene** – the vehicle was left at scene usually due to weather issues till the vehicle could be removed safely from the scene. Officer may not have the information about how damaged the vehicle was at the time of the crash because of the severity of the weather.

### 14 TOW

**DEFINITION:** Describes how it was towed away and allows officers the ability to write a tow number and where it was towed to for their records.

**RATIONALE:** Determines whether a commercial vehicle qualifies for submission to the Federal Motor Carrier Safety Administration systems.

- This field allows the Iowa DOT staff the ability to see if a commercial vehicle meets one of the requirements needed to submit to the FMCSA. There are six selections that can be made and they should match up with the "Extent of Damage" field.

There should not be a vehicle that was listed as code 4 "Disabling damage" or code 5 "Severe, vehicle totaled" in the "Extent of Damage" field being able to have a code 1 "Driven away" in the "Tow" field. The codes are as follows:

Owner's Last Name <b>1</b>				First Name <b>1</b>				Middle Name <b>1</b>				
Address <b>2</b>						City <b>2</b>			State <b>2</b>	ZIP Code <b>2</b>		
License Plate No. <b>3</b>	State: <b>4</b>	Year: <b>4</b>	VIN: <b>5</b>			Color: <b>6</b>	Year: <b>7</b>	Make: <b>8</b>	Model: <b>9</b>	Style: <b>10</b>		
Trailer Plate No.: <b>11</b>	State: <b>12</b>	Year: <b>12</b>	VIN: <b>13</b>			Tow: <b>14</b>	Tow #: <b>15</b>	Towed to: <b>15</b>	Approx. Cost to Repair or Replace <b>16</b>			
Insurance Company Name: <b>17</b>					Insurance Co. Phone Number: <b>17</b>			Insurance Policy Number <b>17</b>				

**15 TOW NUMBER/TOWED TO**

This is for law enforcement use and may contain the tow number and where it was towed to.

**16 COST OF REPAIR OR REPLACE**

**DEFINITION:** This is an estimation of the cost to repair or replace the vehicle.

**RATIONALE:** Used to determine if a crash is reportable or not. It is also used for sanctioning purposes when the party that contributed to the crash does not have insurance and the other parties damages are \$1,500 or more.

Enter an estimate of the approximate cost to repair or replace to the nearest dollar in the **“Approx. Cost to Repair or Replace”** field. If there is an attachment to a vehicle, this amount should be included with the estimated cost of repair.

**17 INSURANCE**

**DEFINITION:** This is the name of the insurance company that is providing coverage on the vehicle, along with the policy and phone number.

**RATIONALE:** The information is used to meet Iowa’s financial responsibility requirements and the coverage is verified with the insurance company.

- a. **“Insurance Company Name”** – the actual name of the insurance company and not the agent from whom the policy was purchased, some examples are Allied, Allstate, Progressive, etc.
- b. **“Insurance Co. Phone Number”** – the phone number is helpful if we have to contact the company and should be found on the insurance card.
- c. **“Insurance Policy Number”** – used by the insurance company to provide required verification of insurance.

Initial Travel Direction 1	Veh. Action 2	Veh. Config. 3	Cargo Body Type 4	Vehicle Defect 5	Point of Initial Impact 6	Most Damaged Area 7	Extent of Damage 8	Total Occip Veh. 9
Special Veh Func 10	Emergency Status 11	Bus Use 12	Driver Condition 13	Vision Obscured 14	Contributing Circumstances Driver (up to two) 15		Driver Distractions 16	Speed Limit 17
Traffic Controls 18	Horizontal Alignment 19	Vertical Alignment 20	SEQUENCE OF EVENTS		First Event 21	Second Event	Third Event	Fourth Event
								Most Harmful

## MOTOR VEHICLE UNIT CODES SECTION

### 1 INITIAL TRAVEL DIRECTION

Enter the “Initial Travel Direction” (direction of travel *before* the crash or loss of control occurred) for each vehicle as shown by entering the direction code). Use the following compass direction codes.

- Code 01** North
- Code 02** East
- Code 03** South
- Code 04** West
- Code 99** Unknown (Should be used only in cases when there is no way to determine direction of travel prior to the crash.)

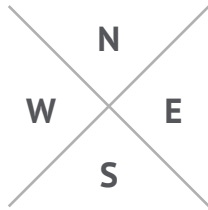

**Warning:** Be sure to enter the initial travel direction and not the driver’s *intended* travel direction. For instance, if a vehicle traveling north is struck in an intersection while turning west, the vehicle’s *initial* travel direction is north, not west.

### 2 VEHICLE ACTION

Enter the appropriate code for each vehicle in the “Veh. Action” field that describes what each vehicle was doing prior to the crash.

**Code 01** **Movement essentially straight** – used when this vehicle’s path of travel was straight ahead on the roadway without any attempted or intended changes.

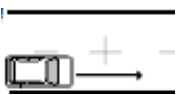

**Code 02** **Turning left** – used when this vehicle was moving forward and turned left, changing lanes from one roadway to a different roadway (e.g., from or to a driveway, parking lot, or intersection).

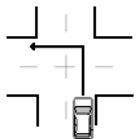

**Code 03** **Turning right** – used when this vehicle was moving forward and turned right, changing lanes from one roadway to a different roadway (e.g., from or to a driveway, parking lot, or intersection).

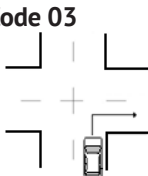

**Code 04**



**Making U-turn** – used when this vehicle was making a U-turn on the trafficway.

**Code 05**

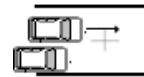

**Overtaking/Passing** – used when this vehicle was traveling straight ahead and was in the process of passing or overtaking another vehicle on the left or right.

**Code 06**



**Changing lanes** – used when this vehicle was traveling straight ahead and changed travel lanes to the right or left while on the same roadway.

**Code 07**

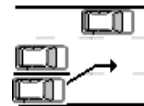

**Entering traffic lane (merging)** – used when this vehicle was moving forward and merging from the left or right into a traffic lane (e.g., roadway narrows, entrance ramps).

**Code 08**

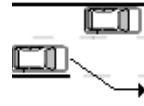

**Leaving traffic lane** – used when this vehicle was moving forward and is leaving a traffic lane merging from the left or right into a traffic lane (e.g., roadway narrows, exit ramps).

**Code 09**



**Backing** – used when this vehicle was traveling backwards within the trafficway. Do not use this attribute if the vehicle was backing into a parking space (see code 18 “Entering a parked position”).

**Code 10**

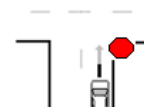

**Slowing/Stopping (decelerating)** – used when this vehicle was traveling straight ahead within the road portion of the trafficway and was decelerating.

**Code 11**

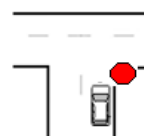

**Stopped in traffic** – used when this vehicle was stopped momentarily, with the motor running within the road portion of the trafficway (e.g., stopped for a traffic signal or waiting for another vehicle to perform a maneuver).

Initial Travel Direction	Veh. Action	Veh. Config.	Cargo Body Type	Vehicle Defect	Point of Initial Impact	Most Damaged Area	Extent of Damage	Total Occip Veh.
1	2	3	4	5	6	7	8	9
Special Veh Func	Emergency Status	Bus Use	Driver Condition	Vision Obscured	Contributing Circumstances Driver (up to two)	Driver Distractions	Speed Limit	
10	11	12	13	14	15	16	17	
Traffic Controls	Horizontal Alignment	Vertical Alignment	SEQUENCE OF EVENTS	First Event	Second Event	Third Event	Fourth Event	Most Harmful
18	19	20		21				

**Code 12**

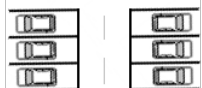

**Legally parked** – a parked motor vehicle is a motor vehicle not in-transport, other than a working motor vehicle, that is not in motion and not located on the roadway (travel lanes). In roadway lanes used for travel during some periods and for parking during other periods, a parked motor vehicle is considered in-transport during periods when parking is forbidden. This attribute includes any stopped motor vehicle where the entirety of the vehicle’s primary outline as defined by the four sides of the vehicle (e.g., tires, bumpers, fenders) and load, if any, is not within the roadway.

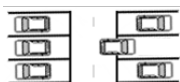

**Illegally parked/unattended** – used when the vehicle was parked illegally or was disabled on trafficway.

**Code 14**

**Negotiating a curve** – applies to vehicles traveling along a curved section of roadway.

**Code 15**

**Starting in road** - is used when this vehicle was in the process of starting forward from a stopped position and intending to proceed straight ahead within the road portion of the trafficway (e.g., start up from traffic signal).

**Code 16**

**Accelerating in road** - is used when this vehicle was traveling straight ahead within the road portion of the trafficway and was accelerating.

**Code 17**

**Leaving a parked position** - is used when this vehicle was entering the travel lane from a parking area adjacent to the traffic lanes (i.e., in the process of leaving the parking position). This attribute includes vehicles that were previously stopped/parked on the shoulder, roadside, median, etc.

**Code 18**

**Entering a parked position** - is used when this vehicle was leaving the travel lane to a parking area adjacent to the traffic lanes (i.e., in the process of parking). This attribute includes vehicles that are stopping/parking on the shoulder, roadside, median, etc.

**Code 98**

**Other** (*explain in narrative*) – is used when this vehicle’s movement is known but none of the specified attributes are applicable. An example would be a vehicle that unintentionally travels (e.g., slips out of gear and rolls) backward.

**Code 99**

**Unknown** – used when a vehicle’s action can’t be determined; just because a vehicle can’t be identified, doesn’t mean its actions are unknown.

**3 VEHICLE CONFIGURATION**

**DEFINITION:** This element indicates the general structure of the vehicle.

**RATIONALE:** The data element provides information about the general structure of the motor vehicle that is important to evaluate the types of motor vehicles that have the most crashes and the effectiveness of the various safety countermeasures.

**Code 01**

**Passenger car**



**Code 02**

**Four-tire light truck (pickup)**



**Code 03**

**Sport utility vehicle (SUV)**  
(small and large)



**Code 04**

**Passenger van** (seats less than nine)



**Code 05**

**Passenger van** (seats nine to 15)  
**Not for bus use**



**Code 06**

**Cargo/Panel van**



**Code 07**

**Single-unit truck** (two axles, six tires)



Initial Travel Direction 1	Veh. Action 2	Veh. Config. 3	Cargo Body Type 4	Vehicle Defect 5	Point of Initial Impact 6	Most Damaged Area 7	Extent of Damage 8	Total Occip Veh. 9
Special Veh Func 10	Emergency Status 11	Bus Use 12	Driver Condition 13	Vision Obscured 14	Contributing Circumstances Driver (up to two) 15	Driver Distractions 16	Speed Limit 17	
Traffic Controls 18	Horizontal Alignment 19	Vertical Alignment 20	SEQUENCE OF EVENTS	First Event 21	Second Event	Third Event	Fourth Event	Most Harmful

**Code 08** Single-unit truck (three axles or more)



**Code 09** Other light truck (less than or equal to 10,000 pounds) *(Describe in narrative)*



**Code 10** Vehicle less than or equal to 10,000 pounds, placarded for HazMat



**Code 11** **Truck/Trailer** – used when a single-unit truck is pulling a trailer. If the truck has no applicable cargo body type, then use the trailer’s cargo body type. Note: Truck trailers can include light trucks (less than 10,000 pounds) pulling trailers that increased the GCWR to over 10,000 pounds. This is different than a tractor-semitrailer (Code 13).



**Code 12** Truck tractor (bobtail)



**Code 13** Tractor/Semitrailer



**Code 14** Tractor/Doubles



**Code 15** **Tractor/Triples** (Not permitted in Iowa without special permission)



**Code 16** Other heavy truck (greater than 10,000 pounds, cannot classify) *(Describe in narrative)*

**Code 17** Motorcycle



**Code 18** Three-wheeled enclosed



**Code 19** Three-wheeled unenclosed



**Code 20** Moped



**Code 21** Motor home/Recreational vehicle



**Code 22** School bus (seats more than 15)



**Code 23** Small school bus (seats nine to 15)



**Code 24** Other bus (seats more than 15)



**Code 25** Other small bus (seats nine to 15)



**Code 26** Farm tractor



**Code 27** Farm vehicle/equipment *(Describe in narrative)*



**Code 28** All-terrain vehicle (ATV)





















Initial Travel Direction 1	Veh. Action 2	Veh. Config. 3	Cargo Body Type 4	Vehicle Defect 5	Point of Initial Impact 6	Most Damaged Area 7	Extent of Damage 8	Total Occip Veh. 9
Special Veh Func 10	Emergency Status 11	Bus Use 12	Driver Condition 13	Vision Obscured 14	Contributing Circumstances Driver (up to two) 15	Driver Distractions 16	Speed Limit 17	
Traffic Controls 18	Horizontal Alignment 19	Vertical Alignment 20	SEQUENCE OF EVENTS	First Event 21	Second Event	Third Event	Fourth Event	Most Harmful

### 4 CARGO BODY TYPE

**DEFINITION:** A description of the vehicle's primary cargo-carrying capability.

**RATIONALE:** Required by Federal Motor Carrier Safety Administration (CFR 350.201). This data element provides additional information about the motor vehicle, including all major cargo body types. The information it provides can be important in helping FMCSA make decisions on regulatory strategies for different types of motor vehicles. This data element is collected at the scene because FMCSA requires reporting within 90 days.

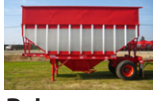
- Code 29 **Snowmobile**  

- Code 30 **Golf cart**  

- Code 31 **Street-legal, low-speed vehicle**  
(These vehicles have a top speed of 30 mph)  

- Code 32 **Limousine/Taxi (seats eight or less)**  

- Code 33 **Limousine/Taxi (seats nine to 15)**  

- Code 33 **Limousine/Taxi (seats more than 15)**  

- Code 35 **Maintenance/Construction vehicle**  
(May also be working on the road or traveling from point to point)  

- Code 36 **Train**  

- Code 98 **Other** *(Describe in narrative)*
- Code 99 **Unknown** *(Describe in narrative)*

- Code 01 **Not applicable**
- Code 02 **Van/Enclosed box** (This is NOT the same as a passenger van.)  

- Code 03 **Dump truck (grain, gravel)**  

- Code 04 **Cargo tank**  

- Code 05 **Flatbed (includes curtain side trailers)**  

- Code 06 **Concrete mixer**  

- Code 07 **Auto transporter**  

- Code 08 **Garbage/Refuse**  

- Code 09 **Hopper (grain, chips, gravel, and granules)**  

- Code 10 **Pole**  

Initial Travel Direction 1	Veh. Action 2	Veh. Config. 3	Cargo Body Type 4	Vehicle Defect 5	Point of Initial Impact 6	Most Damaged Area 7	Extent of Damage 8	Total Occip Veh. 9
Special Veh Func 10	Emergency Status 11	Bus Use 12	Driver Condition 13	Vision Obscured 14	Contributing Circumstances Driver (up to two) 15		Driver Distractions 16	Speed Limit 17
Traffic Controls 18	Horizontal Alignment 19	Vertical Alignment 20	SEQUENCE OF EVENTS	First Event 21	Second Event	Third Event	Fourth Event	Most Harmful

Code 11

Log trailer



Code 12

Intermodal container chassis



Code 13

Small utility trailer (one axle)



Code 14

Large utility (two-plus axles)



Code 15

Boat



Code 16

Camper



Code 17

Large mobile home



Code 18

Oversize load



Code 19

Towed vehicle



Code 20

Bus



Code 98

Other truck cargo type

*(Describe in narrative)*



Code 99

Unknown *(Describe in narrative)*

## 5 VEHICLE DEFECT

**DEFINITION:** Pre-existing motor vehicle defects or maintenance conditions that may have contributed to the crash.

**RATIONALE:** Important for determining the significance of pre-existing problems, including equipment and operation, in motor vehicles involved in crashes that could be useful in determining the need for improvements in manufacturing and consumer alerts.

**Note:** For each vehicle involved in the crash, enter the code in the “**Vehicle defect**” field that best describes any vehicle defect discovered during the course of the investigation that you determine was a factor in the crash or contributed to its severity. If more than one defect exists, choose the one that best describes or most contributed to the crash and make note of others in the “**Narrative**” section of the report. **Example:** *If a vehicle with worn tires is legally stopped at a traffic signal and is rear-ended by another vehicle, the condition of the tires of the stopped vehicle probably had no effect on crash occurrence or severity.*

Code 01

**None** – used when the vehicle does not have any detectable defects.

Code 02

**Brake system** – used when brake systems fail and includes parking brakes.

Code 03

**Steering** – used when the tie rod ends, kingpins, power steering components, or ball joints may have contributed to the crash.

Code 04

**Blowout** – used when the tire blows as the vehicle is in motion.

Code 05

**Other tire defect** *(explain in narrative)* – used when there is a defect with the tire, but it does not blowout.

Code 06

**Wheels** – used when there is a loss of lug nuts.

Code 07

**Windows/windshield** – used when there is a pre-existing defect to the windows or windshield such as improper tinting or cracks.

Code 08

**Wipers** – used when windshield wipers or rear windows wipers are not functioning.

Initial Travel Direction 1	Veh. Action 2	Veh. Config. 3	Cargo Body Type 4	Vehicle Defect 5	Point of Initial Impact 6	Most Damaged Area 7	Extent of Damage 8	Total Occip Veh. 9
Special Veh Func 10	Emergency Status 11	Bus Use 12	Driver Condition 13	Vision Obscured 14	Contributing Circumstances Driver (up to two) 15		Driver Distractions 16	Speed Limit 17
Traffic Controls 18	Horizontal Alignment 19	Vertical Alignment 20	SEQUENCE OF EVENTS	First Event 21	Second Event	Third Event	Fourth Event	Most Harmful

- Code 09**      **Mirrors** – used when there is a pre-existing defect to the mirrors, or they are gone or broken and hanging.
- Code 10**      **Trailer hitch/Truck coupling/Safety chain** – used when there is a defective trailer hitch or an improper trailer hitch.
- Code 11**      **Headlights** – used when one or both headlights are not functioning.
- Code 12**      **Taillight(s)** – used when one or both taillights are not functioning.
- Code 13**      **Turn signal** – used when one of the turn signals are not functioning.
- Code 14**      **Body/door(s)** – used when the body or door(s) contributed to the crash, including the trunk, hood, tailgate, rear doors of cargo vans, etc.
- Code 15**      **Power train** – used when the vehicles power train components may have contributed to the crash. Examples are universal joints, drive shaft, transmission, engine, differential, and stuck throttles.
- Code 16**      **Suspension** – used when the vehicle’s suspension components may have contributed to the crash, including springs, shock absorbers, struts, and control arms.
- Code 17**      **Exhaust** – used when the exhaust systems have failure such as exhaust manifolds, headers, muffler, catalytic converter, tailpipe, etc.
- Code 18**      **Safety systems** – used when there is an indication that the air bags failed to deploy, or the air bag deployed inappropriately or when there is seat belt failure such as webbing excessively worn or came unlatched. This does not include improper use of seat belts.
- Code 98**      **Other** – used when nothing else above fits and should be have an explanation in the narrative.
- Code 99**      **Unknown** – used when it is unknown.

**6 POINT OF INITIAL IMPACT**

Refer to the diagram that represents a vehicle and enter the two-digit number in the “Point of Initial Impact” field that best indicates the point of initial impact where the first damage occurred on the vehicle.

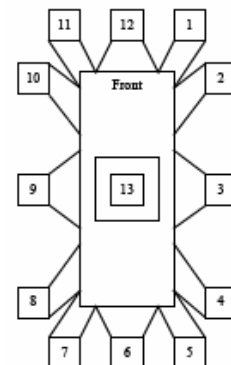

- 14 - Undercarriage
- 15 - Non-collision/no damage
- 16 - Cargo loss
- 98 - Other (explain in narrative)
- 99 - Unknown

**Note:** The diagram appears to represent a car. However, it can be adapted for any type of vehicle or combination. **Example:** *If the vehicle is a truck tractor/ semitrailer combination and the first damage was close to the rear on the driver’s side of the semitrailer, the correct point of initial impact code is 8.*

**7 MOST DAMAGED AREA**

Enter the most damaged area code for the unit, selected from the diagram, in the “Most Damaged Area” field.

**8 EXTENT OF DAMAGE**

Enter the appropriate “Extent of Damage” code. The code and descriptions listed below are provided to help make this determination.

- Code 1**      **None**
- Code 2**      **Minor damage** – used when there is light damage ranges from inconspicuous, slight, or superficial damage to conspicuous damage such as cracked glass, body dents, small holes in the body, and doors that operate with difficulty.
- Code 3**      **Functional damage** – used when there is damage that is not disabling but affects operation of the road vehicle or its parts. This also includes damage that does not prevent a vehicle from being driven a short distance, although further damage would result if the vehicle were driven more than a mile (i.e., flat tires, leaky radiators, bent axles, and wheels that scrape on the body or fenders).

Initial Travel Direction 1	Veh. Action 2	Veh. Config. 3	Cargo Body Type 4	Vehicle Defect 5	Point of Initial Impact 6	Most Damaged Area 7	Extent of Damage 8	Total Occip Veh. 9
Special Veh Func 10	Emergency Status 11	Bus Use 12	Driver Condition 13	Vision Obscured 14	Contributing Circumstances Driver (up to two) 15		Driver Distractions 16	Speed Limit 17
Traffic Controls 18	Horizontal Alignment 19	Vertical Alignment 20	SEQUENCE OF EVENTS	First Event 21	Second Event	Third Event	Fourth Event	Most Harmful

**Code 4**      **Disabling damage** – used when there is damage that precludes departure of the vehicle from the scene of the crash in its usual daylight-operating manner after simple repairs or being pulled from the ditch.

**Code 5**      **Severe, vehicle totaled** – used when there is severe damage is extensive damage; the vehicle may or may not be repairable.

**Code 9**      **Unknown**

“**Extent of Damage**” is one of the methods used to determine whether a commercial motor vehicle (CMV) crash is reportable to the federal government. CMVs with a code 4 or code 5 are expected to be towed unless otherwise explained in the narrative.

## 9 TOTAL OCCUPANTS IN VEHICLE

**DEFINITION:** The number of occupants that are in each vehicle including the driver. For vehicles that left the scene, use 1 for total occupants of that vehicle.

**RATIONALE:** Important to link occupants back to motor vehicles in which they were riding. Necessary, for example, to evaluate the effect motor vehicle type and specific make/model have on occupant protection effectiveness and injury status.

## 10 SPECIAL VEHICLE FUNCTION

**DEFINITION:** The type of special function being served by this vehicle regardless of whether the function is marked on the vehicle.

**RATIONALE:** Important to evaluate the outcome of vehicles used for special uses that are involved in crashes.

**Code 01**      **No special function** – used when the vehicle is not used for any special function.



**Police** – used if the vehicle is equipped with police emergency devices (lights and siren) that is owned or subsidized by any local, county, state, or federal government entity. The police vehicle is presumed to be in special use at all times, although not necessarily in “emergency use.” Vehicles not owned by a government entity that are used by law enforcement officers (e.g., undercover) are excluded.

**Code 03**



**Fire** – used when any readily identifiable (lights or markings) vehicles specially designed and equipped to respond to fire, hazmat, medical, and extrication incidents. This attribute includes medium and heavy vehicles such as engines, pumpers, ladder, platform aerial apparatus, heavy rescue vehicles, water tenders or tankers, brush or wilderness firefighting vehicles, etc.

**Code 04**



**Ambulance** – used when any readily identifiable (lights or markings) vehicles designed to transport sick or injured persons. The ambulance is presumed to be in special use at all times although not necessarily in “emergency use.”

**Code 05**



**Incident response vehicle** – used when government vehicles typically equipped with a variety of tools, including emergency medical equipment; traffic cones and control signs; absorbent material (for responding to spills); and emergency and work lighting. These multipurpose response units are intended to assist law enforcement, fire, and rescue personnel with trafficway incident management.

**Code 06**



**Non-transport emergency service vehicle** – used when any readily identified (lights and markings) vehicles that do not meet the criteria for ambulance, fire truck, or incident response vehicles and are specifically designed and equipped to respond to fire, hazmat, medical, and extrication incidents. This attribute includes light vehicles such as sedans, van, SUVs, pickups, trucks, motorcycles, etc., and includes vehicles that have been dispatched to an incident or have initiated operation in a nonemergency mode and are not transporting passengers, such as patients or suspects. An example is a fire chief’s unit, commonly an SUV.

**Code 07**



**Military** – used when any vehicle owned by any of the Armed Forces regardless of body type, including military police vehicles, military ambulances, military hearses, and military fire vehicles.



Initial Travel Direction 1	Veh. Action 2	Veh. Config. 3	Cargo Body Type 4	Vehicle Defect 5	Point of Initial Impact 6	Most Damaged Area 7	Extent of Damage 8	Total Occip Veh. 9
Special Veh Func 10	Emergency Status 11	Bus Use 12	Driver Condition 13	Vision Obscured 14	Contributing Circumstances Driver (up to two) 15		Driver Distractions 16	Speed Limit 17
Traffic Controls 18	Horizontal Alignment 19	Vertical Alignment 20	SEQUENCE OF EVENTS	First Event 21	Second Event	Third Event	Fourth Event	Most Harmful

**Code 08**



**Snowplow** – used when any vehicle is in the act of removing snow. This would exclude those vehicles in transport to or from work site unless they are clearing the public roadway. Also includes pickups with blade that are removing snow at the time of the crash.

**Code 09**



**Taxi** – used when a vehicle is being used during this trip (at the time of the crash) on a “fee-for-hire” basis to transport persons. Most of these vehicles will be marked and formally registered as taxis; however, vehicles that are used as taxis, even though they are not registered (e.g., Gypsy Cabs) are included here. Passengers do not have to be present at the time of the crash. Taxis and drivers off-duty at the time of the crash are coded as “No special use.” If it is unknown whether or not the taxi is on duty, then code the vehicle as a taxi. This attribute also applies for limousines on a “fee-for-hire” basis.

**Code 10**



**School** – used when any motor vehicle has satisfied all the following criteria. Operated, leased, owned, or contracted by a public or private school-type institution and where the institution’s students may range from pre-school through high school and the occupants are associated with the institution. At the time of the crash the vehicle is being used for transportation to and from a school or on a school sponsored activity or trip. This attribute also includes vehicles that are not externally identifiable as a school/pupil transport vehicle but do meet all of the other criteria above. For example: A transit bus, at the time of the crash, used exclusively (no other passengers except for students) to transport students to/from school or school-related activity.

**Code 98**

**Other** (*explain in narrative*) – used when there is some special use that may not be listed – include what that special use in this field.

**Code 99**

**Unknown** – used when it is unknown if the vehicle was being used for special use.

**11 EMERGENCY STATUS**

**DEFINITION:** Indicates operation of any motor vehicle that is legally authorized by a government authority to respond to emergencies with or without the use of emergency warning equipment, such as a police vehicle, fire truck, or ambulance while actually engaged in such response.

**RATIONALE:** Driver behavior related to emergency vehicle response is an emerging national issue. This is true for both operators of emergency vehicles and operators of vehicles in the vicinity of an emergency vehicle engaged in a response. It is the intent of this element to gather information that will guide development of training or other countermeasures to reduce the number of crashes involving emergency vehicle response.

Emergency status also refers to an official motor vehicle that is usually traveling with emergency signals in use typically red-light blinking, siren sounding, etc. If the vehicle is a special function vehicle such a military, police, ambulance, fire truck, or emergency service vehicle, then determine if the vehicle was on an emergency response at the time of the crash.

**Code 01 Not applicable** – used when this motor vehicle is not on an emergency response.

**Code 02 Yes, warning equipment used** – used when this motor vehicle was in an emergency response and it was using warning equipment at the time of the crash.

**Code 03 Yes, warning equipment not used**- used when this motor vehicle was in an emergency response and it was not using warning equipment as the time of the crash.

**Code 04 No, nonemergency, non-transport-** used when this motor vehicle **was not** in an emergency response and was not transporting anyone.

**Code 05 No, nonemergency transport** – used when this motor vehicle **was not** in an emergency response, but it was transporting someone.

**Code 99 Unknown**



Initial Travel Direction 1	Veh. Action 2	Veh. Config. 3	Cargo Body Type 4	Vehicle Defect 5	Point of Initial Impact 6	Most Damaged Area 7	Extent of Damage 8	Total Occip Veh. 9
Special Veh Func 10	Emergency Status 11	Bus Use 12	Driver Condition 13	Vision Obscured 14	Contributing Circumstances Driver (up to two) 15	Driver Distractions 16	Speed Limit 17	
Traffic Controls 18	Horizontal Alignment 19	Vertical Alignment 20	SEQUENCE OF EVENTS	First Event 21	Second Event	Third Event	Fourth Event	Most Harmful

## 12 BUS USE

**DEFINITION:** This data element describes the common type of bus service this vehicle was being used for at the time of the crash or the primary use for the bus if not in service at the time of the crash.

**RATIONALE:** Important in determining where and how school children are at the greatest risk of injury when being transported by a school bus and the extent to which school bus operations. This is used to help identify how the bus is used when reporting to Federal Motor Carrier Safety Administration and affects overall traffic safety. It also aids in correctly identifying to the FMCSA how the bus was being used at the time of the crash.

Buses are any motor vehicle with seats to transport nine or more people, including the driver's seat. This element does not include vans that are owned and operated for personal use.

**Note:** If the vehicle does not fall into the category for bus leave this element blank.

**Code 01 School (public or private)** – used when vehicles that meet the definition of a bus and are being used by a public or private school, district, or contracted carrier operation on behalf of the entity, providing transport for school children (up to the 12th grade) to/from school (public or private) or any other school function or activity. In addition, school includes buses that are not externally identifiable as a school/pupil transport vehicle. Example: A transit bus, at the time of the crash, used exclusively (no other passengers except students) to transport students to/from the school or school-related activity.

**Code 02 Transit/Commuter** – used when a government entity or private company that provides passenger transportation over fixed, scheduled routes within primarily urban geographical areas, for example inner-city mass transit bus/van service.

**Code 03 Intercity** – used when a company provides for-hire, long-distance passenger transportation between cities over fixed routes with regular schedules. Example: Greyhound bus service between major cities.

**Code 04 Charter/Tour** – used when a company provides transportation on a for-hire basis and demand-response basis, usually round trip service for a tour group or outing.

**Code 05 Shuttle** – used when private companies provide transportation services for their own employees, nongovernmental organizations (such as churches and nonprofit groups), and noneducational units of government (such as departments of corrections). Examples include buses/nine-passenger vans transporting people from airports, hotels, rental car companies, and business facility to facility.

**Code 06 Modified for personal/private use** – used when an individual has modified a bus for personal use such as traveling with their family.

**Code 07 Church** – used when the bus is being used to transport people to/from church and church related functions.

**Code 98 Other** – used when it is a bus that does not fit any of the criteria listed above, explain in the narrative.

**Code 99 Unknown** – used when it is unknown such as a hit and run situation.

## 13 DRIVER CONDITION

**DEFINITION:** This element identifies physical impairments to this driver that may have contributed to the cause of the crash as identified by law enforcement.

**RATIONALE:** Important for evaluating the effect that fatigue, medications/alcohol/drugs, or other conditions have on the crash. Depending on the condition used a review of driving privileges may be made for young drivers or those who contributed.

**Code 01 Apparently normal** – used when there is no indication of impairment exists.

**Code 02 Emotional (e.g., depressed, angry)** – used when the person is arguing with someone, is having a disagreement, is depressed and/or is emotionally upset.

Initial Travel Direction 1	Veh. Action 2	Veh. Config. 3	Cargo Body Type 4	Vehicle Defect 5	Point of Initial Impact 6	Most Damaged Area 7	Extent of Damage 8	Total Occip Veh. 9
Special Veh Func 10	Emergency Status 11	Bus Use 12	Driver Condition 13	Vision Obscured 14	Contributing Circumstances Driver (up to two) 15		Driver Distractions 16	Speed Limit 17
Traffic Controls 18	Horizontal Alignment 19	Vertical Alignment 20	SEQUENCE OF EVENTS	First Event 21	Second Event	Third Event	Fourth Event	Most Harmful

- Code 03**      **Asleep, fatigued** – used when indicated that a person was drowsy or sleepy. Alcohol or other drugs may be the source of this impairment.
- Code 04**      **Illness/Fainted** – used when indicated even if the source of the illness or loss of consciousness is alcohol or drug related.
- Code 05**      **Medical condition (seizure, reaction)** – used when it has been determined that a driver has had/or having a seizure or a reaction to a medical condition such as a diabetic episode.
- Code 06**      **Under the influence of alcohol** – used when the investigating officer indicates that the individual was under the influence of alcohol. When this code is used and there is no test given, it is helpful if this information is put into the narrative to explain why no test was given. If under the legal limit, you should still put the test in the “Alcohol” section if you suspect that it played a factor. This helps to review certain operating while intoxicated (OWI) laws.
- Code 07**      **Under the influence of drugs/meds** – used when there is an indication that the individual is under drugs or having a reaction to medication. It is helpful to put as much information in the narrative about the observation that caused the usage of this code.
- Code 08**      **Physical impairment** – used when a physical impairment is present that may have contributed to the crash.
- Code 09**      **Walks with cane/crutches – used** when the driver is currently restricted to the use of cane/crutches not related to the crash and the officer feels this may have contributed to the crash.
- Code 10**      **Paraplegic/Wheelchair restricted** – used when this person has to use a wheelchair or is paraplegic and the officer feels this may have contributed to the crash.

- Code 11**      **Impaired due to previous injury** – used when the person who is involved in this crash was previously involved in another crash that was subsequent to current incident. This will be a rare occurrence.
- Code 12**      **Hearing impaired/deaf** – used if the driver is hearing impaired or deaf and the officer feels this may have contributed to the crash (i.e., failure to hear siren of emergency vehicle).
- Code 13**      **Visually impaired** – used when the driver is visually impaired, and the officer feels this may have contributed to the crash.
- Code 98**      **Other (explain in narrative)** – used when none of the above fit, explain in the “Narrative” section.
- Code 99**      **Unknown** – used if hit and run drivers.

## 14 VISION OBSCURED

**DEFINITION:** This data element records impediments to a driver’s visual field.

**RATIONALE:** Used to determine if there is something of the roadway that needs to be corrected or what other factors may have contributed to the crash.

- Code 01**      **Not obscured** – used when there is no indication of a visual obstruction for the driver.
- Code 02**      **Trees/Crops** – used when any of these natural features are noted to have obstructed the view of the driver.
- Code 03**      **Embankment** – used when this feature is noted to have obstructed the view of driver and will include a raised embankment or a sag in the roadway.
- Code 04**      **Hillcrest** – used when a hill feature is noted to have obstructed the view of driver.
- Code 05**      **Building(s)** – used when a man-made structure is noted to have obstructed the view of the driver and includes houses, sheds, barns, or storage structures.

Initial Travel Direction 1	Veh. Action 2	Veh. Config. 3	Cargo Body Type 4	Vehicle Defect 5	Point of Initial Impact 6	Most Damaged Area 7	Extent of Damage 8	Total Occip Veh. 9
Special Veh Func 10	Emergency Status 11	Bus Use 12	Driver Condition 13	Vision Obscured 14	Contributing Circumstances Driver (up to two) 15		Driver Distractions 16	Speed Limit 17
Traffic Controls 18	Horizontal Alignment 19	Vertical Alignment 20	SEQUENCE OF EVENTS	First Event 21	Second Event	Third Event	Fourth Event	Most Harmful

- Code 06**      **Sign/Billboard** – used when a man-made structure is noted to have obstructed the view of the driver and includes traffic signs, poles, signals, etc.
- Code 07**      **Parked vehicles** – used when a vehicle that is parked in a designated parking area or space, stopped in an area off the roadway or is a working motor vehicle is noted to have obstructed the view of the driver. The vehicle may be but does not have to a contact vehicle but did contribute to the crash.
- Code 08**      **Moving vehicles** – used when a vehicle that is in motion or stopped on the roadway is noted to have obstructed the view of the driver. The vehicle may be but does not have to be a contact vehicle but did contribute to the crash.
- Code 09**      **Person/Object in or on vehicle** – used when a person or object inside the vehicle or on the vehicle obstructs the view of the driver.
- Code 10**      **Blinded by sun or headlights** – used when the glare from the sun or headlights obstructed the view of the driver.
- Code 11**      **Broken/Dirty windshield** – used when the windshield is either broken or dirty and obstructs the view of the driver.
- Code 12**      **Frosted windows/windshield** – used when the windows or windshield is frosted over and obstructs the view of the driver.
- Code 13**      **External mirrors** – used when an exterior mirror on this driver’s vehicle created a visual obstruction do to its size or placement.
- Code 14**      **Blowing snow** – used when the blowing of snow is a factor in the obstruction of the driver’s view.
- Code 15**      **Fog/Smoke/Dust** – used when one or more of these conditions exist and are noted to have obstructed the view of the driver. Do not use this attribute when only the vehicle windshield is described as fogged as this would fall under code 12 “Frosted windows/windshield.”
- Code 16**      **Splash/Spray of passing vehicle** – used when this condition is noted to have obstructed the view of the driver. The splash or spray can come from water or mud; however, the use of this attribute does not require it to be raining at the time of the crash.
- Code 17**      **Inadequate vehicle lighting** – used when the driver’s vision was impaired because the exterior lighting system (including headlights, fog lights, etc.) of the driver’s vehicle was deficient in some way. This would include being turned off or not operating properly. This response should not be used to describe inadequate lighting systems of other vehicles (e.g., oncoming motor vehicles) or for inadequate highway lighting.
- Code 18**      **Exterior angle/blind spot on vehicle** – used when the size of shape of a driver’s own vehicle created a visual obstruction, including trailer, vehicle height, and blind spot. Not to be confused with visual obstructions from other vehicles or a vehicle’s interior components such as head restraints, sunshades, etc.
- Code 98**      **Other** (*explain in narrative*) – used when none of the above fit and should be explained in the narrative.
- Code 99**      **Unknown** – used when the vehicle is a hit and run.

Initial Travel Direction 1	Veh. Action 2	Veh. Config. 3	Cargo Body Type 4	Vehicle Defect 5	Point of Initial Impact 6	Most Damaged Area 7	Extent of Damage 8	Total Occip Veh. 9
Special Veh Func 10	Emergency Status 11	Bus Use 12	Driver Condition 13	Vision Obscured 14	Contributing Circumstances Driver (up to two) 15		Driver Distractions 16	Speed Limit 17
Traffic Controls 18	Horizontal Alignment 19	Vertical Alignment 20	SEQUENCE OF EVENTS	First Event 21	Second Event	Third Event	Fourth Event	Most Harmful

## 15 CONTRIBUTING CIRCUMSTANCES DRIVER

**DEFINITION:** The actions by the driver that may have contributed to the crash. This data element is based on the judgment of the law enforcement officer investigating the crash and need not match violation codes.

**RATIONALE:** Important for evaluating the effect that dangerous driver behavior has on crashes. You can use up to two contributing circumstances for the driver you feel best fit the situation you are investigating. Contributing circumstance information is used to review an individual for unsafe driving practices and may cause either a re-exam or some type of sanction action.

- Code 01**      **Ran traffic signal** – used when the driver did not stop at a traffic signal when it was red.
- Code 02**      **Ran stop sign** – used when the driver did not stop at a “stop” traffic sign.
- Code 03**      **Exceeded authorized speed** – used when the driver was going over the posted speed limit.
- Code 04**      **Driving less than the posted speed limit** – used when the driver is driving too slow which impedes traffic.
- Code 05**      **Driving too fast for conditions** – used when the driver is driving too fast for conditions on the road that would cause a failure to have control. Examples would be icy conditions, oil slicks, or work zones areas in which the driver is not able to slow rapidly or keep control of vehicle if necessary.
- Code 06**      **Lost control** – used when the driver is unable to maintain control of the vehicle for any reason.
- Code 07**      **Following too close** – used when the driver has not allowed enough space between his vehicle and the vehicle in front of him so that they are able to stop quickly. Also is used if they are following a fire truck too closely, failure to maintain safe passing distance between trucks, or following vehicles in caravan too closely to allow entry.

- Code 08**      **Operating vehicle in a reckless/erratic/careless/negligent manner** – used when the driver is driving in such a manner that endangers others or has a wanton disregard for the safety of other vehicles or non-motorists on the roadway. This could be used for those cases in which you know that the vehicles have been drag racing.
- Code 09**      **Improper or erratic lane changing** – used when the driver is making unsafe lane changes.
- Code 10**      **Aggressive driving/road rage** – used when there is evidence to support that the driver exhibited road rage or is acting in an unsafe manner such as acceleration followed by sudden braking.
- Code 11**      **Made improper turn** – used when the driver was making a right turn from left-turn lane; left turn from right-turn lane; or is making a too wide right or left turn or making a unsafe U-turn (from shoulder, etc.).
- Code 12**      **Failed to yield to emergency vehicle** – used when the driver fails to yield to an emergency vehicle that has lights and sirens engaged or to a stopped school bus or other emergency vehicle that requires the driver to stop.
- Code 13**      **Traveling wrong way/on wrong side** – used when the driver is driving the wrong way on a one-way street or is driving on the wrong side of the roadway either intentional or unintentional.
- Code 14**      **Traveling on prohibited trafficway** – used when vehicles are using a trafficway they are prohibited from using. Example: A moped on the interstate or trucks using a roadway that is prohibited to them.
- Code 15**      **Over-correcting/Over-steering** - used when the officer has reason to believe the driver was over-correcting or over-steering and the action contributed to the crash.



Initial Travel Direction 1	Veh. Action 2	Veh. Config. 3	Cargo Body Type 4	Vehicle Defect 5	Point of Initial Impact 6	Most Damaged Area 7	Extent of Damage 8	Total Occip Veh. 9
Special Veh Func 10	Emergency Status 11	Bus Use 12	Driver Condition 13	Vision Obscured 14	Contributing Circumstances Driver (up to two) 15		Driver Distractions 16	Speed Limit 17
Traffic Controls 18	Horizontal Alignment 19	Vertical Alignment 20	SEQUENCE OF EVENTS	First Event 21	Second Event	Third Event	Fourth Event	Most Harmful

**Code 16**      **Failed to keep in proper lane** – used when the driver crosses the centerline and strikes oncoming vehicle. Vehicle is going straight in turn lane or is using more than one lane on its side of a multilane highway and crosses the lane of travel currently being used but not for purposes of passing or changing lanes. This attribute does not apply to vehicles that run off the roadway (there is usually some other reason for this such as failure to have control, swerving, etc.) or that cross the median (would fall under driving on wrong side).

**Code 17**      **Failure to signal intentions** – used when there is an indication that the driver did not use turning signals or in the case of a motorcyclist who failed to use hand signals.

**Code 18**      **Swerved to avoid vehicle/object/non-motorist/animal in roadway** – used when the driver indicates that they had to swerve to avoid another vehicle, object in the roadway, animal, or a non-motorist that would include a bicyclist, pedestrian, horse and buggy, horse rider, and wheelchair occupant.

**Code 19**      **Starting or backing improperly** – used when the driver made unsafe start from a parked position such as backing up on a one-way or starting onto a highway from a parked position on shoulder.

**Code 20**      **Failure to dim lights/ have lights on** – used when the driver failed to dim lights to oncoming vehicles or did not have their lights on when needed. Example: Foggy weather or night time/early morning driving, when it is difficult to see another vehicle clearly without lights.

**Code 21**      **Vehicle stopped on railroad tracks** – used when the driver has the vehicle stopped on railroad tracks either intentionally or unintentionally.

**Code 22**      **Vehicle drove around grade crossing gates** – used when the driver drives around the crossing gate.

### This next section deals with “Passing” contributing circumstances.

**Code 30**      **On wrong side** – used when the driver is passing another vehicle on the wrong side.

**Code 31**      **Where prohibited by signs/markings** – used when the driver is passing where they are prohibited by either signs or markings on the road.

**Code 32**      **With insufficient distance/inadequate visibility** – used when the driver was passing with insufficient sight distance.

**Code 33**      **Through/Around barrier** – used when the driver drove through a barrier or roadblock or drove around it. Road closures would be an example.

**Code 96**      **Other passing** (*explain in narrative*) – used when none of the other attributes for passing is correct for the situation. Be sure to explain in narrative to assist with any updates that may be needed in future rewrites.

### This section deals with “Failed to Yield Right of Way (FTYROW).”

**Code 40**      **From stop sign** – used when the driver failed to yield from a sign marked “Stop.” Not to be confused with running the stop sign as the driver has stopped but then failed to wait until any other vehicle that has the right of way has cleared.

**Code 41**      **From yield sign** – used when the driver failed to yield from a sign marked “Yield.”

**Code 42**      **Making left turn** – used when the driver failed to yield while making a left-hand turn.

**Code 43**      **Making a right turn on red signal** – used when the driver failed to yield while making a right turn while the signal light is red.

**Code 44**      **From driveway** – used when the driver fails to yield while turning onto a roadway from a driveway (includes business driveway and parking lots, as well as residential driveways).



Initial Travel Direction 1	Veh. Action 2	Veh. Config. 3	Cargo Body Type 4	Vehicle Defect 5	Point of Initial Impact 6	Most Damaged Area 7	Extent of Damage 8	Total Occip Veh. 9
Special Veh Func 10	Emergency Status 11	Bus Use 12	Driver Condition 13	Vision Obscured 14	Contributing Circumstances Driver (up to two) 15		Driver Distractions 16	Speed Limit 17
Traffic Controls 18	Horizontal Alignment 19	Vertical Alignment 20	SEQUENCE OF EVENTS	First Event 21	Second Event	Third Event	Fourth Event	Most Harmful

**Code 45**      **From parked position** – used when the driver fails to yield while coming from a parked position.

**Code 46**      **To non-motorist** – used when the driver fails to yield to a bicyclist, pedestrian, skater, or any other non-motorist.

**Code 47**      **At uncontrolled intersection** – used when the driver failed to yield in an uncontrolled intersection.

**Code 97**      **Other FTYROW** (*explain in narrative*) – used when none of the other FTYROW attributes fit the crash being investigated. Be sure to explain in the narrative so that it can be noted for future re-writes.

**Code 55**      **Towing improperly** – used when towing with improper connection (e.g., only a cable, etc.) or using vehicle to push another vehicle.

**Code 56**      **Getting off/out of vehicle** – used for either moving or nonmoving vehicles. Example: When a driver opens door to leave vehicle in front of moving traffic.

**Code 57**      **Overloading/Improper loading with passengers/cargo** – used when the driver has more than three passengers in the front seat or the trunk is open with extra-large cargo protruding. Also includes sitting/standing on rails, tailgate of pickup, or improperly sitting in bed of pickup. Being overweight/over length or oversized.

**Code 58**      **Operator inexperience** – used when the driver’s inexperience has contributed to the crash. Used when there is a new driver, new truck/bus driver, or the driver is unfamiliar with vehicle they are driving. This is based on the judgment of the investigating officer.

**Code 88**      **No improper action** – used when the officer feels that the driver did nothing to contribute to the crash. **Note:** *You cannot have a two-vehicle crash and both drivers having a code 88 otherwise there would not have been an incident to report, at least one of the drivers must have another attribute.*

**Code 98**      **Other** (*explain in narrative*) – used when none of the other attributes fit the situation you are investigating. Explain in narrative so this can be taken into consideration for any future updates.

**Code 99**      **Unknown** – used when you have a driver who you have no information for because they left the scene. Any information that is updated later after the driver is found may be resubmitted to the department by using a photocopy of the report and marking it as a supplemental or retransmitting through TraCS.

**This section deals with “Other” situations and would need to have explanation put in the “Narrative” section.**

**Code 50**      **Vision obstructed** – used when the driver’s vision is obstructed, and this contributes to the crash.

**Code 51**      **Operating without required equipment** – used when the driver is driving without the proper required equipment (i.e., left-hand mirror).

**Code 52**      **Failure to obey displayed vehicle warnings or instructions** – used when the driver failed to follow construction instructions (e.g., arrows directing traffic mounted on vehicle), instructions on emergency vehicles (ambulances, fire trucks, police cars). Failure to observe right turn warning on trucks or buses and failure to heed hazard lights on disabled vehicle or school bus arm.

**Code 53**      **Disregard signs/road markings** – used when the driver disregarded any signs or road markings. Not used when in passing as there is another attribute for that under passing contributing circumstances.

**Code 54**      **Illegal off-road driving** – used when the driver is driving off pavement or roadway (physically driving on shoulder, in ditch, on sidewalk, or on median).

Initial Travel Direction 1	Veh. Action 2	Veh. Config. 3	Cargo Body Type 4	Vehicle Defect 5	Point of Initial Impact 6	Most Damaged Area 7	Extent of Damage 8	Total Occip Veh. 9
Special Veh Func 10	Emergency Status 11	Bus Use 12	Driver Condition 13	Vision Obscured 14	Contributing Circumstances Driver (up to two) 15		Driver Distractions 16	Speed Limit 17
Traffic Controls 18	Horizontal Alignment 19	Vertical Alignment 20	SEQUENCE OF EVENTS		First Event 21	Second Event	Third Event	Fourth Event

## 16 DRIVER DISTRACTIONS

**DEFINITION:** This element identifies the attribute that best describes this driver's attention to driving prior to the driver's realization of an impending critical event or just prior to impact if realization of an impending critical event does not occur. Distraction from the primary task of driving occurs when drivers divert their attention from the driving task to some other activity and can be inside the motor vehicle (internal) or outside the motor vehicle (external). Also, driving while daydreaming or lost in thought is identified as distracted driving by the National Highway Traffic Safety Administration. Physical conditions/impairments (fatigue, alcohol, medical condition, etc.) or psychological states (anger, emotional, depressed, etc.) are not identified as distractions by NHTSA, but are located in the "Driver Condition" section.

**RATIONALE:** Important to identify specific driver behavior during a crash and understand and mitigate the effects of distracting activities.

**Note:** Record the attribute that best describes this driver's attention to driving prior to the driver's realization of an impending critical event or just prior to impact if realization of an impending critical event does not occur.

When coding this element, witness statements, including those from vehicle passengers or pedestrians, may be used to provide information to the officer and should be included in the "Narrative" section of the report. If you have written statements provided by these sources, they can also be attached.

Because of the nature of the rise in crashes stemming from driver distractions this is a required field that needs to be completed to aid in preventive tactics.

**Code 01**      **Not applicable/No driver** – used when there is no driver present in the vehicle because it is parked or left unattended for any reason.

**Code 02**      **Not distracted** – used when the driver was completely attentive to driving.

This section deals with distractions using electronic devices.

- Code 03**      **Manual operation of an electronic communication device (texting, typing, dialing)** – used when the driver was texting, typing, or dialing on any electronic device.
- Code 04**      **Talking on hand-held device** – used when the driver was talking on a cell phone or any other hand-held device.
- Code 05**      **Talking on hands-free device** – used when the driver was talking on a device that is not held in the hand but may be attached to the vehicle as a source of power or is located in the ear.
- Code 06**      **Adjusting devices (radio, climate)** – used when someone is distracted from the driving task while adjusting the air conditioner, heater, radio, cassette, using the radio, using the cassette, CD or any other music-related device that are mounted in the vehicle, global positioning system, or adjusting any other device that is located inside of the vehicle. Also is used when there is an adjustment to door locks, adjusting sideview mirrors, speed controls, or seat. It is helpful to know what exactly the distraction was in the narrative (i.e., driver was adjusting radio).
- Code 96**      **Other activity with electronic device (explain in narrative)** – used when any activity that is not covered with the above attributes. Please explain in narrative to aid in any upgrades needed to the codes in the future.

Initial Travel Direction 1	Veh. Action 2	Veh. Config. 3	Cargo Body Type 4	Vehicle Defect 5	Point of Initial Impact 6	Most Damaged Area 7	Extent of Damage 8	Total Occup. Veh. 9
Special Veh. Func. 10	Emergency Status 11	Bus Use 12	Driver Condition 13	Vision Obscured 14	Contributing Circumstances Driver (up to two) 15		Driver Distractions 16	Speed Limit 17
Traffic Controls 18	Horizontal Alignment 19	Vertical Alignment 20	SEQUENCE OF EVENTS	First Event 21	Second Event	Third Event	Fourth Event	Most Harmful

**This section is related to other distractions inside the vehicle.**

**Code 10** **Passenger** – used when the driver was distracted by another occupant in this driver’s vehicle prior to crash. Example: Conversing with or looking at another occupant (e.g., baby/child in back seat, rowdy teenager, argumentative spouse, etc.).

**Code 11** **Unrestrained animal** – used when the driver is distracted by an animal that is unrestrained inside of the vehicle. Example: Holding animal on lap; animal running beneath driver’s feet; animal moving between windows in the front or back portion of the vehicle.

**Code 12** **Eating or drinking related** – used when the driver is eating or drinking or involved in an activity related to these actions (e.g., picking food from carton placed on passenger seat, reaching to throw out used food wrapper, etc.).

**Code 13** **Smoking related** – used when the driver is smoking or involved in an activity related to smoking, such as lighting his cigarette, putting his ashes in the ash tray, etc.

**Code 14** **Reaching for object(s)/fallen objects** – used when the driver is reaching for an object that is located on the seat next to them or in the back of the front seat(s) or is reaching for an object that has fallen. A cigarette that has fallen would be used here instead of smoking related.

**Code 15** **Inattentive/lost in thought** – used when the driver is not completely attentive to driving because they are thinking about items other than the driving tasks.

**Code 16** **Looked but did not see** – used when the driver is paying attention to driving (not distracted), but does not see the relevant vehicle, object, etc. This attribute should be used when a driver has an opportunity to take some action prior to impact, but the driver takes no action and no distractions apply. This situation frequently occurs when an overtaking vehicle is in the

driver’s “blind spot” or at intersections when a crossing vehicle is not noticed. If the driver sees the vehicle, object, etc., but does not consider it a danger, and no distractions apply then the “Not Distracted” would be used.

**Code 97** **Other distraction inside vehicle** (*explain in narrative*) – used if you know there was a distraction, but it does not fit in any of the above categories. Please explain in the narrative to aid in any upgrades to the codes needed in the future.

**Code 98** **Distraction outside vehicle** (*explain in narrative*) – used when the driver was distracted by an outside person, object, or event prior to realization of impending danger. **Example:** *Animals on the roadside; a previous crash or nontraffic-related signs (e.g., advertisements, electronic billboards, etc.).*

**Code 99** **Unknown** – used when the driver is unknown.

**17 SPEED LIMIT**

**DEFINITION:** This is the posted speed limit and speed limits are in 5 mph increments. Refer to the highway speed limit that is operational at the time and place of the crash whether physically displayed or not.

**RATIONALE:** This element identifies the value indicated that best represents the speed limit just prior to this vehicle’s critical pre-crash event.

**Note:** Try not to confuse advisory signs (black on yellow) on entrance/exit ramps or near intersections with the actual legal maximum speed limit (regulatory – black on white). Disregard advisory or other speed signs because they do not indicate the legal speed limit.



When coding “**Speed Limit**” for roadways with two different speed limits, use the speed limit for the direction of travel where the critical pre-crash event **begins**.

Initial Travel Direction 1	Veh. Action 2	Veh. Config. 3	Cargo Body Type 4	Vehicle Defect 5	Point of Initial Impact 6	Most Damaged Area 7	Extent of Damage 8	Total Occip Veh. 9
Special Veh Func 10	Emergency Status 11	Bus Use 12	Driver Condition 13	Vision Obscured 14	Contributing Circumstances Driver (up to two) 15		Driver Distractions 16	Speed Limit 17
Traffic Controls 18	Horizontal Alignment 19	Vertical Alignment 20	SEQUENCE OF EVENTS	First Event 21	Second Event	Third Event	Fourth Event	Most Harmful

## 18 TRAFFIC CONTROLS

**DEFINITION:** The type of traffic control device (TCD) applicable to this motor vehicle at the crash location.

**RATIONALE:** This element needs to be collected at the scene because the presence of specific devices is better verified at the time of the crash. It is also important for determining the relationship between the use of TCDs and crashes and identifying the need for upgraded TCDs at specific crash locations.

**Note:** The roadway used for coding this element is the one this vehicle departed if it is off the roadway just prior to its critical pre-crash event. If this vehicle is in a junction just prior the crash, then this element is coded based on the roadway this vehicle was on before entering the junction. Code this element whether the device was functioning or not. If more than one device is present, use the one that is more relevant in the crash. Example: There is a stop sign but a law enforcement officer is directing traffic, it is more relevant to use the code 10 “Traffic director.”

If a traffic control is out due to a power failure and has a temporary control, the control that is temporarily being used should be recorded.

Guide signs do not constitute traffic controls and pavement markings are not considered as traffic control devices.

You may have a regulatory speed limit sign along with another traffic control device. Example: A warning sign for a dangerous condition in which the warning sign is more relevant and should be used.

Another set of questions arises from the issue of proximity of the device to the crash. Judgment must be applied in these situations. Typical signs that create such problems are “Do Not Pass” signs where a no passing zone extends for miles but is only marked at the beginning of the zone and other such signs that may pertain to a significant length of road. In these instances, if the crash occurs within reasonably close proximity of the sign and the sign type is relevant to the crash, it may be appropriate to code the sign.

### Code 01

**No controls present** – used when at the time of the crash, there was no intent to control (regulate or warn) vehicle traffic. Use this attribute if statutory controls apply (e.g., state law requires that when two vehicles meet at an uncontrolled intersection, the one on the right has the right-of-way). Also used when a traffic control is deactivated (e.g., traffic signal that emits no signals) during certain times of the day and was deactivated at the time of the crash. A traffic control that has just been installed and not yet activated is also coded as no control.

### Code 02



**Traffic signal** – used when there is any highway traffic signal by which traffic is alternatively directed to stop and permitted to proceed utilizing the colors of red, yellow, and green.

### Code 03



**Flashing traffic control signal** – used when there is a single colored head and flashes. This attribute should be used if it is a highway traffic signal that is flashing or includes a flashing red beacon that appears with a stop sign.

### Code 04



**Stop sign** – used when there is a traffic sign used to control vehicular traffic, usually erected at road junctions, that instructs drivers to stop and then to proceed only if the way ahead is clear.

### Code 05



**Yield sign** – used when there is a yield sign, which indicates a vehicle driver must slow down and prepare to stop if necessary usually while merging into traffic on another road but needn't stop if the way is clear.

### Code 06



**No passing zone (marked)** – used when there is a regulatory sign, which informs highway users of traffic laws or regulations and indicate the applicability of legal requirements that would not otherwise be apparent. In this case, passing is not allowed due to visibility or other dangerous issues with the road.



Initial Travel Direction 1	Veh. Action 2	Veh. Config. 3	Cargo Body Type 4	Vehicle Defect 5	Point of Initial Impact 6	Most Damaged Area 7	Extent of Damage 8	Total Occip Veh. 9
Special Veh Func 10	Emergency Status 11	Bus Use 12	Driver Condition 13	Vision Obscured 14	Contributing Circumstances Driver (up to two) 15		Driver Distractions 16	Speed Limit 17
Traffic Controls 18	Horizontal Alignment 19	Vertical Alignment 20	SEQUENCE OF EVENTS	First Event 21	Second Event	Third Event	Fourth Event	Most Harmful

Code 07



**Warning sign** – used when there is a sign warning traffic of existing or potentially hazardous conditions on or adjacent to a highway or street.

Code 08



**School zone sign** – used when there is a sign informing traffic users of a school in the area and that drivers should be watching for pedestrian traffic. If the sign was in effect at the time the crash occurred, it doesn't matter whether or not children were present. If the sign is flashing, use this attribute rather than "flashing traffic control signal."

Code 09

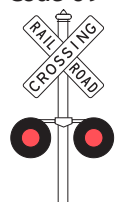

**Railway crossing device** – used when there is a crossing device to alert the driver of a train approaching. If the crossing has a flashing light, use this attribute instead of the flashing light. Other forms of warning may be wigwags, bells, and crossbucks.

Code 10



**Traffic director (person)** – used when a person (e.g., police officer, crossing guard, flagman, or officially designated person) is in the act of controlling both vehicular and pedestrian traffic.

Code 11



**Work zone sign** – used when there is a work zone present and used to warn vehicular traffic of a lane shift, uneven surface, worker ahead, etc.

Code 12

**Inoperative (not functioning properly)** – used when the device was not operating properly and there was no other traffic device present.

Code 13

**Traffic sign missing** – used when the device is missing completely.

Code 98

**Other** – used for any other device that functions as a traffic control device not listed as an attribute listed above. Example: Barricades, cones, drums, and object markers. Note this in the narrative.

Code 99

**Unknown** – used when the information is unknown. An example is that a driver is reporting they hit a deer and there is no investigation into the site.

## 19 HORIZONTAL ROADWAY ALIGNMENT

**DEFINITION:** The geometric or layout and inclination characteristics of the roadway in the direction of travel for this vehicle.

**RATIONALE:** Important to document the horizontal alignment and grade of the roadway as it relates to this specific vehicle involved in the crash for the purpose of evaluating vehicles that run-off-road, rollover, or are runaways.

**Note:** For vehicles departing the trafficway prior to their crash, the trafficway selected for classification is the one the vehicle departed.

Enter the description of the "Horizontal Alignment."

Code 01

**Straight** – used when the roadway is straight.

Code 02

**Traversing curve to left** – used when this vehicle's roadway is curved to the left.

Code 03

**Traversing curve to right** – used when this vehicle's roadway is curved to the right.

Code 98

**Other (explain in narrative)** – used when it is a non-trafficway area for example this vehicle is entering a trafficway but was not on a trafficway prior to the crash.

Code 99

**Unknown** – used when it is unknown, usually in the case of no investigating officer present at the site but crash is being reported for insurance purposes.



Initial Travel Direction	Veh. Action	Veh. Config.	Cargo Body Type	Vehicle Defect	Point of Initial Impact	Most Damaged Area	Extent of Damage	Total Occip Veh.
1	2	3	4	5	6	7	8	9
Special Veh Func	Emergency Status	Bus Use	Driver Condition	Vision Obscured	Contributing Circumstances Driver (up to two)	Driver Distractions	Speed Limit	
10	11	12	13	14	15	16	17	
Traffic Controls	Horizontal Alignment	Vertical Alignment	SEQUENCE OF EVENTS	First Event	Second Event	Third Event	Fourth Event	Most Harmful
18	19	20		21				

## 20 VERTICAL ATTRIBUTES/ ROADWAY GRADE

**DEFINITION:** The geometric or layout and inclination characteristics of the roadway in the direction of travel for this vehicle.

**RATIONALE:** Important to document the horizontal alignment and grade of the roadway as it relates to this specific vehicle involved in the crash for the purpose of evaluating vehicles that run-off-road, rollover, or are runaways.

**Note:** For vehicles departing the trafficway prior to their crash, the trafficway selected for classification is the one the vehicle departed. If this vehicle is in a junction just prior to its critical pre-crash event, the roadway selected for classification is the one it is on before entering the junction.

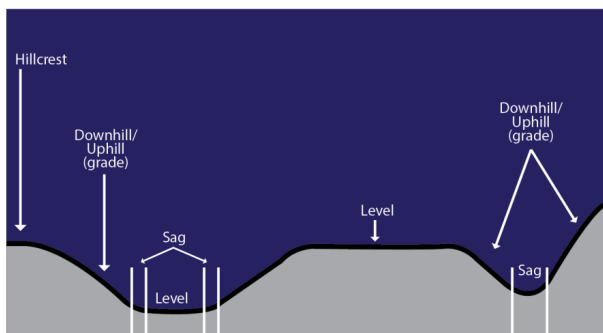

- Code 01**      **Level** – used when the roadway is level.
- Code 02**      **At crest** – used when at top of hill before descending or when you are done ascending.
- Code 03**      **Traversing uphill** – used when traveling uphill.
- Code 04**      **Traversing downhill** – used when traveling downhill.
- Code 05**      **At sag (bottom of hill)** – used when the transitioning between a change of grade at the bottom of a hill. It is not a dip, which is a flaw.
- Code 98**      **Other** (*explain in narrative*) – used when none of the above attributes apply example may be a dip, which is a flaw in the road due to erosion.
- Code 99**      **Unknown** – used when officer has not completed an investigation into the crash.

## 21 SEQUENCE OF EVENTS/ MOST HARMFUL EVENT

**DEFINITION:** The events in sequence related to **this** motor vehicle, from **this** motor vehicle's perspective, including both collision and non-collision events.

**RATIONALE:** Important for use in conjunction with most harmful event and motor vehicle maneuver to generate complete information about the crash.

The crash events table records in chronological sequence, the set of events resulting from an unstabilized situation that constitutes a motor vehicle traffic crash. The “crash” is concluded in time when all events that originate from the unstabilized situation are stabilized. The crash events table is designed to provide a coded description of all qualifying events that occurred in the crash.

With this coded chronological sequence of qualified crash events, traffic safety analysts can review the entire series of events involving in-transport motor vehicles. Various areas of concern to the highway safety community can be easily assessed using this data. For instance, the injury severity in crashes can be assessed relative to the number and type of impacts involved. Likewise, certain collision configurations that may create a greater hazardous condition for the occupants can be identified. Other possible areas of analysis would be the mix of vehicles sizes or the types of objects the different classes of vehicles impact.

To complete the “**Sequence of Events**” section, each event for each vehicle is recorded in the order in which they occur, timewise, based on the description of the crash from the crash report narrative, diagram, or other relevant case materials. “**Sequence of Events**” includes both harmful and nonharmful events that occur in the crash. Recording of the events ends at the last harmful event of the entire crash. Therefore, a nonharmful or pre-crash events (e.g., crossing the centerline) that occurs following the last harmful event of the crash will not be included.

For each vehicle involved in the crash, enter the number codes that best describe the events in sequence relating to the crash, including both non-collisions as well as collision events. Space is provided to record up to four events in sequence. While it may not be necessary to enter four events in every crash, investigators should enter as many events as possible that pertain to each crash. Some crashes may have more than four events. In this case, investigators should record the **first four** significant events in sequence in the fields: “**First Event**,” “**Second Event**,” “**Third Event**,” and “**Fourth Event**.” Additional events may be documented in the “**Narrative**” section of the report.

Initial Travel Direction 1	Veh. Action 2	Veh. Config. 3	Cargo Body Type 4	Vehicle Defect 5	Point of Initial Impact 6	Most Damaged Area 7	Extent of Damage 8	Total Occip Veh. 9
Special Veh Func 10	Emergency Status 11	Bus Use 12	Driver Condition 13	Vision Obscured 14	Contributing Circumstances Driver (up to two) 15	Driver Distractions 16	Speed Limit 17	
Traffic Controls 18	Horizontal Alignment 19	Vertical Alignment 20	SEQUENCE OF EVENTS	First Event 21	Second Event	Third Event	Fourth Event	Most Harmful

Additionally, investigators should enter the code number that best describes the “Most Harmful Event” related to the crash. The “Most Harmful Event” can be defined as the event that results in the most severe injury or, if no injury, the greatest property damage involving this vehicle. In most cases, the “Most Harmful Event” will be one of your selections in the “Sequence of Events” section, so the same code would be listed in two boxes.

**A. PRE-CRASH EVENTS:** These events, *except* “8 – Cargo/Equipment loss or shift,” cannot be listed as the “Most Harmful” or “First Harmful Events” because they did not cause the damage but are a prelude to the crash. **Example:** *Running off the road to the right does not cause damage; it is the hitting of some object or person that is the collision event or damage from a non-collision event such as overturning.*

*All codes in red are a Harmful Event.*

- Code 01** **Ran off road, right** (see Appendix I on [page 110](#) for examples) – used when the vehicle leaves the traveled portion of the roadway on the right side of the road.
- Code 02** **Ran off road, straight** – used when the vehicle leaves the traveled portion of the roadway straight ahead, would usually be an intersection that is not a four-way.
- Code 03** **Ran off road, left** – used when the vehicle leaves the traveled portion of the roadway on the left side of the road.
- Code 04** **Cross centerline (undivided)** – used when the vehicle crossed a centerline that is in on an undivided roadway.
- Code 05** **Crossed median (divided)** – used when a vehicle completely crosses the median (raised or grassy) and enters the shoulder or travel lanes on the opposite side of a divided highway.
- Code 06** **Evasive action (swerve, panic braking, avoidance)** – used when a vehicle uses some sort of evasive action that causes them to go into another travel portion or leave the roadway.
- Code 07** **Downhill runaway** – used when a vehicle that was not intending to move rolls downhill. Example: A parked vehicle with no driver comes out of

gear and rolls downhill or a vehicle that is jacked up and being worked on and it slips off the jack and rolls down the hill.

- Code 08** **Cargo/Equipment loss or shift** – used when there is a loss or shift of items carried on or in a motor vehicle or its trailing unit.
- Code 09** **Equipment failure (tires, brakes, etc.)** – used when equipment failure of some type causes the vehicle to lose control. The type of equipment failure should be placed under “Vehicle Defect.”
- Code 10** **Towed portion came apart (separation of unit)** – used when a trailing unit separates from its power unit or another trailing unit.
- Code 11** **Loss of traction** – used when either weather or some other element is present that causes a vehicle to lose traction with the pavement. This could also be an intentional act by the driver (i.e., wheelie or bouncing cars).
- Code 12** **Trailer fishtailing or swaying** – used when the pulled unit does not come apart but it sways or fishtails causing the vehicle’s driver to lose control. This could be weather related and then should have a “Weather Condition” code to reflect the condition that would cause the trailer to sway.
- Code 13** **Animal (avoided hitting)** – used when the animal was not hit but by their presence caused the driver to lose control.
- Code 94** **Other pre-crash (explain in narrative)** – used when none of the above attribute will work and explain in narrative for any future updates.

**B. NON-COLLISION EVENTS**

- Code 20** **Overturn/Rollover** – used when a motor vehicle rotates (rollover) at least one-quarter turn onto its side or end. For motorcycles, laying the motorcycle down on its side is sufficient to code this as a rollover/overturn and a harmful event if damage or injury is produced, even though the data

Initial Travel Direction 1	Veh. Action 2	Veh. Config. 3	Cargo Body Type 4	Vehicle Defect 5	Point of Initial Impact 6	Most Damaged Area 7	Extent of Damage 8	Total Occip Veh. 9
Special Veh Func 10	Emergency Status 11	Bus Use 12	Driver Condition 13	Vision Obscured 14	Contributing Circumstances Driver (up to two) 15	Driver Distractions 16	Speed Limit 17	
Traffic Controls 18	Horizontal Alignment 19	Vertical Alignment 20	SEQUENCE OF EVENTS	First Event 21	Second Event	Third Event	Fourth Event	Most Harmful

element rollover is not applicable to motorcycles. Ground is not to be entered in conjunction with this element.

**Code 21** **Jackknife** – used when there is a condition that occurs to an articulated vehicle, any vehicle with a trailing unit(s) connected by a hitch (e.g., truck tractor or single-unit truck with one or more trailers, articulated bus, car pulling a boat on a trailer, etc.) while in motion. The condition reflects a loss of control of the vehicle's driver in which the trailer(s) yaw(s) from its normal straight-line path behind the power unit, striking the power unit, and causing damage to the power unit or trailer. Jackknife should only be coded as a harmful event if there is clear indication of damage to the jackknifed vehicle or injury to its occupants caused by the jackknife.

**Code 22** **Non-contact vehicle (phantom)** – when the driver avoids contact with another vehicle that is reported as a non-contact or phantom vehicle. This includes a moving, parked, or working vehicle.

**Code 23** **Vehicle went airborne** – used when the vehicle left the ground. Example: The vehicle drove off a cliff, the vehicle was launched into the air after striking another vehicle, or after traversing a berm (a narrow shelf, path or ledge typically at the top or bottom of a slope and a mound or wall of earth or sand or the shoulder of a road.) Not to be used when the vehicle was going airborne during a rollover event.

**Code 24** **Fell/Jumped from vehicle** – used when an occupant of this vehicle falls or jumps (not suicide) from the vehicle causing injury. Example: An occupant of a motor vehicle in transport leans against the car door, it opens, and the occupant falls out; or a person riding on a vehicle's exterior (hood, roof, running board, etc.) falls or jumps, and is injured by the fall. If an occupant falls or jumps from a vehicle and is struck by that vehicle, use this attribute.

**Code 95** **Other non-collision** (*explain in narrative*) – used when it involves one vehicle and none of the other attributes fits the situation.

### C. COLLISION WITH - EXCEPT 34

**Code 30** **Collision with thrown or falling object** – used when any object is thrown (intentionally or unintentionally) and impacts an in-transport vehicle or the object falls onto, into, or in the path of an in-transport motor vehicle. If a tree limb falls from a tree and is contacted by a car or a person maliciously throws an object off an overpass into traffic below, this attribute is used. This excludes contacts made by loads or objects set in-motion by a motor vehicle, then the code 38 **“Struck/Struck by object/cargo/person from other vehicle”** is used.

**Code 31** **Collision with animal** – used when an animal is struck.

**Code 32** **Collision with non-motorist** ([see “Non-motorist” section](#)) – used when a non-motorist such as a pedestrian, bicyclist, horse and buggy, etc., is struck. **Do not** make non-motorist a unit. Units are only for those vehicles that are propelled by a motor or engine.

**Code 33** **Collision with vehicle in traffic/transit (moving)** – used when a motor vehicle hits another motor vehicle, this would include motorcycles, moped, etc., but excludes horse and buggy and other non-motorists. This should also be used for vehicles on private property that are “moving/in transit” with a driver. Also, if the vehicle is stopped at a traffic light, waiting for traffic to clear before turning, or for a parking spot to open, the vehicle is still considered to be “a vehicle in traffic/transit”.

**Code 34** **Re-entering roadway** – used when a vehicle that departed the roadway portion of the trafficway returns to the same roadway. Example: A motor vehicle in transport runs off the roadway right, strikes the guardrail face, and then re-enters the roadway.

Initial Travel Direction 1	Veh. Action 2	Veh. Config. 3	Cargo Body Type 4	Vehicle Defect 5	Point of Initial Impact 6	Most Damaged Area 7	Extent of Damage 8	Total Occip Veh. 9
Special Veh Func 10	Emergency Status 11	Bus Use 12	Driver Condition 13	Vision Obscured 14	Contributing Circumstances Driver (up to two) 15	Driver Distractions 16	Speed Limit 17	
Traffic Controls 18	Horizontal Alignment 19	Vertical Alignment 20	SEQUENCE OF EVENTS	First Event 21	Second Event	Third Event	Fourth Event	Most Harmful

This is not used when a vehicle is just entering the road from a driveway.

**Code 35 Collision with parked motor vehicle –** used when the impact occurred between a motor vehicle in-transport and a parked motor vehicle. A parked motor vehicle is a motor vehicle not in-transport, other than a working motor vehicle, that is not in motion and not located on the roadway (travel lanes). In roadway lanes used for travel during some periods and for parking during other periods, a parked motor vehicle is considered in-transport during periods when parking is forbidden.

**Code 36 Collision with work zone maintenance equipment –** used when a motor vehicle contacted is in the act of performing construction, maintenance, or utility work related to the trafficway when it became an involved unit. This “work” may be located within open or closed portions of the trafficway and motor vehicles performing these activities can be within or outside of the trafficway boundaries. The code does not include private construction/ maintenance vehicles or vehicles such as garbage trucks, delivery trucks, taxis, emergency vehicles, tow trucks, etc.

Some examples of when you would use Code 36:

- An asphalt/steam roller working in a highway construction zone paving the roadway or flattening dirt.
- A state highway maintenance crew painting lane lines on the road, mowing grass on the roadside, or median, repairing potholes, removing debris from the roadway, etc.
- A utility truck or a “cherry picker” performing maintenance on power lines along the roadway or maintaining a traffic signal.
- A private excavating company contracted by the state digging the

foundation for a new overpass.

- A street sweeper sweeping the street.
- A vehicle in a mobile work convoy displaying arrow boards or other signaling devices warning motorists of the work activity.

**Code 37 Collision with railway vehicle/train –** used when any land vehicle that is designed primarily for, or in use for, moving persons or property from one place to another on rails is involved in crash.

**Code 38 Struck/Struck by object/cargo/ person from other vehicle –** used when the injury or damage producing event is two motor vehicles in-transport making contact by something set-in-motion by one of the vehicles. In crashes involving harmful events caused by objects set-in-motion by a motor vehicle in transport, remember that a vehicle’s load is considered part of the vehicle and these are considered all one unit. Example: If cargo falls from a truck and strikes another motor vehicle, this is treated as a two-vehicle crash even if the two vehicles do not actually touch each other. If cargo falls from a truck and strikes a pedestrian or other non-motorist, the proper attribute would be code 32 “Non-motorist.”

**Code 96 Collision with other nonfixed object (explain in narrative) –** used when the collision involves a motor vehicle colliding with another nonfixed object and none of the other attributes fit the situation.



Initial Travel Direction 1	Veh. Action 2	Veh. Config. 3	Cargo Body Type 4	Vehicle Defect 5	Point of Initial Impact 6	Most Damaged Area 7	Extent of Damage 8	Total Occip Veh. 9
Special Veh Func 10	Emergency Status 11	Bus Use 12	Driver Condition 13	Vision Obscured 14	Contributing Circumstances Driver (up to two) 15	Driver Distractions 16	Speed Limit 17	
Traffic Controls 18	Horizontal Alignment 19	Vertical Alignment 20	SEQUENCE OF EVENTS	First Event 21	Second Event	Third Event	Fourth Event	Most Harmful

## D. COLLISION WITH A FIXED OBJECT

### Bridge Components

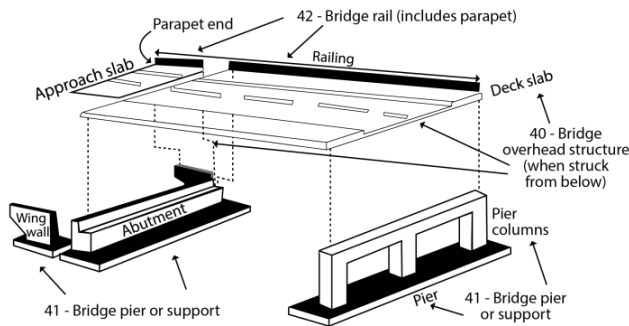

**Code 40** **Collision with bridge overhead structure** – used when striking the bottom of a bridge while traveling on a trafficway underneath the bridge.

**Code 41** **Collision with bridge pier or support** – used when striking the square or round column of stone, concrete, brick, steel, or wood for supporting a bridge between abutments. This attribute includes the bridge abutments that support the ends of a bridge. Abutments are generally designed for retaining or supporting the embankment under bridge ends and composed of stone, concrete, brick, or wood (includes the wing walls).

**Code 42** **Collision with bridge/Rail parapet** – used when striking the wooden, brick, stone, concrete, or metal fence-like structure that runs along the outermost edge of the roadway or sidewalk on the bridge or a rail constructed along the top of a parapet. Bridges do not need to support another roadway but may be an overpass for a train or even for a viaduct (water conduit).

**Code 43** **Collision with curb/Island/Raised median** - used when any of the following are struck. Curb is a concrete or asphalt structure that borders the roadway. It provides drainage control and pavement edge delineation. The face of the curb may be sloped or vertical. Raised median provides space to locate pedestrian safety feature, landscaping, and storm water management. A raised island can be

used to narrow the traveled way, either in midblock locations, or to create gateways to entrances.

**Code 44** **Collision with ditch** – used when any man-made structure for drainage purposes is struck. A ditch ends where a culvert begins and resumes on the opposite of the culvert. A collision with the sides of a ditch (“ditchbank” or “ditch embankment”) should be coded as a Ditch rather than an embankment.

**Code 45** **Collision with embankment** – used when a raised structure to hold back water, carry a roadway, or the result of excavation or washout (including erosion) that may be faced with earth, rock, stone, or concrete. An embankment is usually differentiated from a wall by its incline, whereas a wall is usually vertical.

**Code 46** **Collision with ground** – used when the impact is with an earthen or paved surface off of the roadway. “Ground” is not to be used when the harmful event is a “Rollover/Overturn.” Example: When a snowmobile comes out of a ditch and lands on the road causing damage to the vehicle, but the vehicle did not rollover or overturn. This code will not be used often.

**Code 47** **Collision with culvert/Pipe opening** – used when a man-made drain or channel crossing under a road, sidewalk, etc., is struck.

**Code 48** **Collision with guardrail face** – used when a when a guardrail face, which is a low barrier, that has the primary longitudinal structure composed of metal (plates, mesh, box beam, etc.) is struck. A guardrail is differentiated from code 50 “Concrete traffic barrier” by the material making up the greatest part of the longitudinal portion of the structure. In the case of guardrails, this is metal whereas in concrete barriers it is concrete (including concrete rails).

**Code 49** **Collision with guardrail end** – used when a vehicle strikes the end of a guardrail. Guardrails can have a separate flat or rounded piece of metal



Initial Travel Direction 1	Veh. Action 2	Veh. Config. 3	Cargo Body Type 4	Vehicle Defect 5	Point of Initial Impact 6	Most Damaged Area 7	Extent of Damage 8	Total Occip Veh. 9
Special Veh Func 10	Emergency Status 11	Bus Use 12	Driver Condition 13	Vision Obscured 14	Contributing Circumstances Driver (up to two) 15	Driver Distractions 16	Speed Limit 17	
Traffic Controls 18	Horizontal Alignment 19	Vertical Alignment 20	SEQUENCE OF EVENTS	First Event 21	Second Event	Third Event	Fourth Event	Most Harmful

- Code 50** **Collision with concrete traffic barrier** – used when the longitudinal traffic barriers constructed of concrete are struck. This includes all temporary concrete barriers regardless of location (i.e., temporary Jersey barrier on a bridge being used to control traffic during bridge repair/construction). Concrete walls (vertical side surfaces) do not apply here but are code 64 “Walls.”

**Code 57** **Collision with other post/pole/support-** *(explain in narrative)* – used for posts other than highway signs (e.g., reflectors on poles alongside of roadway, parking meters, flag poles, etc.).
- Code 51** **Collision with other traffic barrier** - *(explain in narrative)* – used for all other longitudinal barriers such as wood or rock and unknown barrier composition type.

**Code 58** **Collision with fire hydrant** – used when the roadside device used by fire departments to provide water for fighting fires is struck. Usually made of steel, these devices are also referred to as fire plugs or fire standpipes in some areas.
- Code 52** **Collision with cable barrier** – used when the flexible barrier system, which uses several cables typically supported by steel posts, is struck. These barriers are designed to help lessen the impact or keep vehicles within the confines of the road.

**Code 59** **Collision with mailbox** – used when a private residence mail/newspaper box, including the post, is struck. A cluster of private mailboxes is included in this attribute. This element does not include a U.S. mailbox, which are typically blue and are for general public use, these would be code 97 “**Other fixed object.**”
- Code 53** **Collision with impact attenuator/crash cushion** – used when a device for controlling the absorption of energy released during vehicle collision (crash cushion) is struck. Its most common application involves the protection of fixed-roadside objects such as bridge piers, elevated gores at exit ramps, etc. Example: Barrels filled with water or sand; plastic collapsible structures.

**Code 60** **Collision with tree** – used when a vehicle strikes a standing tree. This includes impacts from overhanging branches or tree stumps. If a vehicle strikes a tree lying in the roadway, use code 96 “**Other nonfixed object.**” If a tree falls on a vehicle as it is passing by, use code 30 “**Thrown or falling object.**”
- Code 54** **Collision with utility pole/light support** – used when the poles or supports for electrical, telephone, cable, lighting, and other utility pole type is struck.

**Code 61** **Collision with landscape/shrubbery** – used to refer to vegetation that is usually of a woody, multi-stemmed variety and in most instances is low-growing rather than tall. These may also be called bushes. Also used for the enhancement to the appearance of land, especially around buildings, by altering its contours, shrubs, and flowers.
- Code 55** **Collision with traffic sign support** – used when the post supporting traffic sign or the sign itself is hit by a motor vehicle. This includes mile marker posts and signs above the trafficway.

**Code 62** **Collision with snowbank** – used when snowfall and/or road plowing creates an essentially fixed barrier of snow/ice that are not snow-covered earth or rock embankments.
- Code 56** **Collision with traffic signal support** – used when the post supporting a traffic signal or the signal itself is hit by a motor vehicle.

**Code 63** **Collision with fence** – used when a fence or fence post is struck and can be made of wood, chain link, stone, etc.

Initial Travel Direction 1	Veh. Action 2	Veh. Config. 3	Cargo Body Type 4	Vehicle Defect 5	Point of Initial Impact 6	Most Damaged Area 7	Extent of Damage 8	Total Occip Veh. 9
Special Veh Func 10	Emergency Status 11	Bus Use 12	Driver Condition 13	Vision Obscured 14	Contributing Circumstances Driver (up to two) 15	Driver Distractions 16	Speed Limit 17	
Traffic Controls 18	Horizontal Alignment 19	Vertical Alignment 20	SEQUENCE OF EVENTS	First Event 21	Second Event	Third Event	Fourth Event	Most Harmful

**Code 64** **Collision with wall** – used for a primarily vertical structure composed of concrete, metal, timber, or stone that is not part of a building or a fence but typically is used for retaining earth, abating noise, and separating area (but not for containment as in the primary function of a fence). Also included are headwalls (or end walls) that are sometimes provided on culvert ends principally to protect the sides of the embankment around the culvert opening against erosion. This does not include wing walls, which are attached to ends of bridge abutments and extend back at an angle from the roadway. Wing walls should use code 41 “**Bridge pier or support.**”

**Code 65** **Collision with building** – used when the vehicle impacts a roofed and walled structure build for permanent use. The type of construction material used is not of interest, nor is the use of the building.

**Code 97** **Collision with other fixed object** (*explain in narrative*) – used when the object is fixed (considered a permanent structure) and is not described by any of the other fixed-object attributes.

## E. MISCELLANEOUS EVENTS

**Code 70** **Fire/Explosion** – used for a vehicle fire or explosion that occurs during the crash sequence or as a result of the crash. As it pertains to the occurrence of a fire or explosion, the crash circumstances are not considered stabilized until the threat of damage to this vehicle or injury consequences to this vehicle’s occupants has ceased. The event is not considered stabilized until all occupants have exited the vehicle and the scene has been declared safe by police or other authority. Fires that occur at a later time to vehicles abandoned at the scene (e.g., in open fields, on hillsides, etc.) or to vehicles removed from the scene to another location (tow yard, curbside, etc.) are not considered part of the crash.

**Code 71** **Immersion** – used when a motor vehicle enters a body of water and results in injury or damage. *Note: In immersion injuries/fatalities, the injury to the person may be noted as “drowning.”*

**Code 72** **Hit and run** – used when the vehicle left the scene. This should not be the first or only sequence. The object they hit should be listed in the Sequence of Events prior to this selection. This also applies when the driver flees the scene on foot. This really is only for the “run” part.

**Code 73** **Elding law enforcement** – used when the motor vehicle is trying to avoid being stopped by law enforcement.

**Code 74** **Gas inhalation/asphyxiation** – used when an injury or death results from toxic fumes such as carbon monoxide fumes leaking from the motor vehicle.

**Code 75** **Vehicle out of gear/rolled** – used when the vehicle comes out of gear and rolls causing damage or injury.

**Code 98** **Other** (*explain in narrative*) – used when none of the other attributes apply to the situation.

**Code 99** **Unknown** – used when you don’t know all events due to a vehicle that has left the scene, or it is unknown what was hit.

## COMMERCIAL MOTOR VEHICLE SECTION

Carrier Name/Lessee <b>1</b>									
Street Address <b>1</b>						City <b>1</b>		State <b>1</b>	ZIP Code <b>1</b>
Number of Axles <b>2</b>		Gross Veh. Weight Rating <b>3</b>		US DOT Number <b>4</b>			MC Number <b>5</b>		Underride/Override <b>6</b>
Haz Mat Involvement <b>7</b>		Haz Mat Placard <b>8</b>	Placard Number <b>9</b>	Haz Mat Released <b>10</b>	Haz Mat Class <b>11</b>	Haz Mat Name <b>12</b>			
Trailer Plate: <b>13</b>	State <b>14</b>	Year <b>14</b>	VIN <b>15</b>						
Trailer Plate: <b>16</b>	State <b>17</b>	Year <b>17</b>	VIN <b>18</b>						
Converter Dolly <b>19</b>		Dolly Plate: <b>20</b>	State <b>21</b>	Plate Year <b>21</b>	VIN <b>22</b>				

**DEFINITION:** Information collected concerning commercial vehicles, includes vehicles capable of carrying eight or more people (including the driver) and vehicles display a hazardous materials placard, regardless of weight.

**RATIONALE:** Required by the Federal Motor Carrier Safety Administration (CFR 350.201). The FMCSA has the authority to fine and sanction unsafe interstate (and some intrastate) truck and bus companies. A keyway to identify potentially unsafe motor carriers is to collect crash data by the identification number (USDOT number), name and address of the company. The street address allows FMCSA staff to visit carriers and review compliance with FMCSA Regulations and provides a cross-check for the correct identity of the carrier. The USDOT number, found on the power unit and assigned by the U.S. DOT or by a state, is a key element for carrier identifications and the FMCSA databases for crashes and for other carrier information. This data element is collected at the scene to meet the FMCSA's 90-day reporting requirement.

**This section must be completed if any of the following applies:**

1. Any truck that has a gross vehicle weight rating (GVWR) of 10,001 pounds or more, or a gross combination weight rating (GCWR) of 10,001 pounds or more.
2. Any motor vehicle with seating to transport nine (9) or more people, including the driver's seat.
3. Any motor vehicle displaying a hazardous materials placard (regardless of weight).

**AND** any of the following are true.

1. Any of the vehicles involved in the crash were towed due to disabling damages. The towed vehicle does not have to be the commercial motor vehicle (CMV).
2. Any party involved in the crash suffered injuries for which immediate treatment was necessary away from the scene. This code is not for those treated at the scene and released.
3. A fatality occurred.

Carrier Name/Lessee <b>1</b>									
Street Address <b>1</b>						City <b>1</b>		State <b>1</b>	ZIP Code <b>1</b>
Number of Axles <b>2</b>		Gross Veh. Weight Rating <b>3</b>		US DOT Number <b>4</b>			MC Number <b>5</b>		Underride/Override <b>6</b>
Haz Mat Involvement <b>7</b>		Haz Mat Placard <b>8</b>	Placard Number <b>9</b>	Haz Mat Released <b>10</b>	Haz Mat Class <b>11</b>	Haz Mat Name <b>12</b>			
Trailer Plate: <b>13</b>	State <b>14</b>	Year <b>14</b>	VIN <b>15</b>						
Trailer Plate: <b>16</b>	State <b>17</b>	Year <b>17</b>	VIN <b>18</b>						
Converter Dolly <b>19</b>		Dolly Plate: <b>20</b>	State <b>21</b>	Plate Year <b>21</b>	VIN <b>22</b>				

**Note:** If the crash occurred on private property, the “CMV” section does not need to be completed.

## 1 CARRIER NAME/LESSEE

- a. Enter the carrier’s name (an individual, partnership, or corporation) in the “**Carrier Name/Lessee**” field. The identification of the carrier can be found in three different ways.
- The carrier’s name may be displayed on both sides of the vehicle, usually the driver’s side door of the cab.
  - The carrier’s name should be on the shipping papers carried by the driver, on the driver’s log, or on the lease agreement. In the case of a bus, the driver carries a trip manifest, or a charter order, which gives the name of the motor carrier.
  - Ask the driver for the carrier’s name.
- b. Clearly enter the carrier’s principal place of business in the carrier’s “**Address, City, State, ZIP Code**” fields.

## 2 NUMBER OF AXLES

Enter the total number of axles on the vehicle, including the power unit and trailers in the “**Number of Axles**” field.

## 3 GVWR

**DEFINITION:** The gross vehicle weight rating (GVWR) is the amount recommended by the manufacturer as the upper limit to the operational weight for the motor vehicle and any cargo (human or other) to be carried. The gross combination weight rating (GCWR) is the sum of all GVWRs for each unit in the combination unit motor vehicle (power unit plus trailer(s)). Thus for single-unit trucks, there is no difference between the GVWR and GCWR. For combination trucks, the GCWR is the total of the GVWRs of all the units in the combination.

**RATIONALE:** Required by the Federal Motor Carrier Safety Administration (CFR 350.201). The FMCSA imposes certain regulations on all single or combination unit trucks that have a GCWR of more than 10,001 pounds. Additional regulations are imposed on all motor vehicles with a

GVWR/GCWR of more than 26,000 pounds. This data element is collected at the scene because FMCSA requires reporting within 90 days.

Select the correct range for the GVWR/GCWR for the unit(s).

If GVWR of the power unit is less than 10,001 pounds, the GVWR for the trailer should be combined with that of the power unit.

<b>Code 1</b>	<b>10,000 pounds or less</b>
<b>Code 2</b>	<b>10,001-26,000 pounds</b>
<b>Code 3</b>	<b>26,001 pounds or greater</b>

## 4 USDOT NUMBER

- Enter the USDOT number in the “**USDOT Number**” field, when applicable. If there is no USDOT number available, leave the field blank.
- The USDOT number should be displayed on the power unit of the CMV and are usually found on one or both doors.
- The number for the USDOT number will be numerical with a length of seven digits or less and preceded by “USDOT.”

## 5 MOTOR CARRIER NUMBER

- Enter the motor carrier number in the “**MC Number**” field, when applicable. If there is no motor carrier number available, leave the field blank.
- The motor carrier number should be displayed on the power unit of the CMV and are usually found on one or both doors.
- The motor carrier number will be numeric with a length of six digits or less and preceded by “MC.”



Carrier Name/Lessee 1									
Street Address 1						City 1		State 1	ZIP Code 1
Number of Axles 2		Gross Veh. Weight Rating 3		US DOT Number 4			MC Number 5		Underride/Override 6
Haz Mat Involvement 7		Haz Mat Placard 8	Placard Number 9	Haz Mat Released 10	Haz Mat Class 11	Haz Mat Name 12			
Trailer Plate: 13	State 14	Year 14	VIN 15						
Trailer Plate: 16	State 17	Year 17	VIN 18						
Converter Dolly 19		Dolly Plate: 20	State 21	Plate Year 21	VIN 22				

## 6 UNDERRIDE/OVERRIDE

**DEFINITION:** This element indicates whether an underride/override occurred for all vehicles during the crash.

**RATIONALE:** Needed to identify the magnitude of crashes in which an underride or override occurs to support National Highway Traffic Safety Administration rule-making activities in motor vehicle bumper compatibility research.

- a. An underride refers to a vehicle sliding under another vehicle during the crash.
  - b. An override refers to a vehicle riding over top of another vehicle during the crash.
- Note:** Either can occur with a parked vehicle.
- c. Select the appropriate code in the “**Underride/Override**” field.
  - d. If one unit is override, the other unit is underride

**Code 1**            **None**

**Code 2**            **Underride, compartment intrusion**



**Code 3**            **Underride, no compartment intrusion**



**Code 4**            **Underride, compartment intrusion unknown**



**Code 5**            **Override, moving vehicle**



**Code 6**            **Override, parked/stationary vehicle**



**Code 7**            **Unknown (explain in narrative)**

## 7 HAZMAT INVOLVEMENT

**DEFINITION:** Hazardous material is a substance or material that has been designated by the U.S. DOT or other authorizing entity as capable of posing an unreasonable risk to health, safety, and property when transported in commerce.

**RATIONALE:** This element identifies the presence of hazardous cargo for this vehicle and records information about the hazardous cargo when present.

**Code 01**            **Yes** – used when hazardous materials were indicated for this vehicle.

**Code 02**            **No** – used when there is no indication of hazardous materials for this vehicle.

**Code 03**            **Not applicable** – used when the vehicle involved is not capable of carrying hazardous material.

**Code 99**            **Unknown (explain in narrative)**

Carrier Name/Lessee 1									
Street Address 1						City 1		State 1	ZIP Code 1
Number of Axles 2		Gross Veh. Weight Rating 3		US DOT Number 4			MC Number 5		Override/Override 6
Haz Mat Involvement 7		Haz Mat Placard 8	Placard Number 9		Haz Mat Released 10	Haz Mat Class 11	Haz Mat Name 12		
Trailer Plate: 13	State 14	Year 14	VIN 15						
Trailer Plate: 16	State 17	Year 17	VIN 18						
Converter Dolly 19		Dolly Plate: 20	State 21	Plate Year 21		VIN 22			

## 8 HAZMAT PLACARD

**DEFINITION:** This element indicates the presence of a diamond panel indicating the presence of hazardous material being transported.

**RATIONALE:** Data collected is used to calculate the risk assessment, determine response methods, and develop regulations. Vehicles carrying hazardous materials are required to carry shipping papers containing the hazmat class and identification number.

- Code 01**      **Yes** – used when hazardous materials are involved.
- Code 02**      **No** – used when hazardous materials are involved, but officer indicates there is no placard.
- Code 03**      **Not applicable** – used when there is no indication of hazardous materials for this vehicle.
- Code 99**      **Unknown** (*explain in narrative*)

## 9 PLACARD NUMBER

**DEFINITION:** Four-digit hazardous material identification number or name taken from the middle of a diamond or rectangle box located on the vehicle.

**RATIONALE:** Data collected is used to calculate the risk assessment, determine response methods, and develop regulations. Vehicles carrying hazardous materials are required to carry shipping papers containing the hazmat class and identification number.

- Enter the hazardous material class number in the “Placard Number” field.
- If number is unknown, leave the field blank.

## 10 HAZMAT RELEASED

**DEFINITION:** This element indicates whether any hazardous cargo was released from the cargo tank or compartment.

**RATIONALE:** Required by the Federal Motor Carrier Safety Administration (CFR 350.201). The FMCSA devotes special attention to motor carriers that transport hazardous material, including calculating risk assessments, determining response methods, imposing higher regulations, and conducting compliance reviews on a higher percentage of hazmat carriers. Getting good data on crashes involving trucks carrying hazmat, and whether hazmat are spilled during the crash, helps FMCSA focus law enforcement efforts. This data element is collected at the scene because FMCSA requires reporting within 90 days.

- The intent of this field is to determine whether any of the placarded material was released or escaped from its transport container into the environment.
- Fuel or oil carried by the vehicle for its own use is not considered cargo and should not be reported in this field.

- Code 01**      **Yes** – used when there is hazardous material involved and was released from the material(s) cargo compartment.
- Code 02**      **No** – used when there is hazardous material involved but was not released from the cargo compartment.
- Code 03**      **Not applicable** – used when there is no hazardous material involved.
- Code 99**      **Unknown** (*explain in narrative*)

Carrier Name/Lessee 1									
Street Address 1						City 1		State 1	ZIP Code 1
Number of Axles 2		Gross Veh. Weight Rating 3		US DOT Number 4			MC Number 5		Override/Override 6
Haz Mat Involvement 7		Haz Mat Placard 8	Placard Number 9	Haz Mat Released 10	Haz Mat Class 11	Haz Mat Name 12			
Trailer Plate: 13	State 14	Year 14	VIN 15						
Trailer Plate: 16	State 17	Year 17	VIN 18						
Converter Dolly 19		Dolly Plate: 20	State 21	Plate Year 21	VIN 22				

### 11 HAZMAT CLASS

**DEFINITION:** This element indicates a single-digit hazardous material class number for the vehicle.

**RATIONALE:** Data collected is used to calculate the risk assessment, determine response methods, and develop regulations. Vehicles carrying hazardous materials are required to carry shipping papers containing the hazmat class and identification number.

- a. Enter the one-digit hazardous material class number in the “**Hazmat Class**” field.
- b. If you are given a two-digit number with a decimal point, record only the first digit in the “**Hazmat Class**” field.

### 13 TRAILER PLATE

**DEFINITION:** This element identifies the registration information for the first trailing unit attached to the power unit.

**RATIONALE:** Used to identify the registration information for the trailer or towed vehicle and to confirm the identity of the owner/carrier.

- a. Trailing unit applies to any device connected to a motor vehicle by a hitch, including tractor-trailer combinations, a single-unit truck pulling a trailer, etc.
- b. **Note:** This is **not** for the power unit plate. This is for the trailer or other unit attached to the power unit.
- c. Enter the plate number in the “**Trailer Plate**” field.

### 12 HAZMAT NAME

**DEFINITION:** This element indicates the name of the hazardous material being transported.

**RATIONALE:** Required by the Federal Motor Carrier Safety Administration (CFR 350.201). The FMCSA devotes special attention to motor carriers that transport hazardous material, including calculating risk assessments, determining response methods, imposing higher regulations, and conducting compliance reviews on a higher percentage of hazmat carriers. Getting good data on crashes involving trucks carrying hazmat, and whether hazmat are spilled during the crash, helps FMCSA focus law enforcement efforts. This data element is collected at the scene because FMCSA requires reporting within 90 days.

- a. Enter the name of the material being transported in the “**Hazmat Name**” field.
- b. If you have two materials in the same class, report the material in greatest quantity, if you have the information.
- c. If you do not have the information, report the material that is listed first on the shipping papers or manifest.

### 14 TRAILER PLATE STATE/YEAR

**DEFINITION:** This element identifies the state in which the trailing unit was registered.

**RATIONALE:** Used to identify the state in which the trailing unit was registered, for confirmation of ownership.

- a. Enter two-digit state abbreviation in the “**State**” field.
- b. Enter the validation year on the sticker in the “**Year**” field as this would show the most current year of registration.

Carrier Name/Lessee <b>1</b>									
Street Address <b>1</b>						City <b>1</b>		State <b>1</b>	ZIP Code <b>1</b>
Number of Axles <b>2</b>		Gross Veh. Weight Rating <b>3</b>		US DOT Number <b>4</b>			MC Number <b>5</b>		Override/Override <b>6</b>
Haz Mat Involvement <b>7</b>		Haz Mat Placard <b>8</b>	Placard Number <b>9</b>	Haz Mat Released <b>10</b>	Haz Mat Class <b>11</b>	Haz Mat Name <b>12</b>			
Trailer Plate: <b>13</b>	State <b>14</b>	Year <b>14</b>	VIN <b>15</b>						
Trailer Plate: <b>16</b>	State <b>17</b>	Year <b>17</b>	VIN <b>18</b>						
Converter Dolly <b>19</b>		Dolly Plate: <b>20</b>	State <b>21</b>	Plate Year <b>21</b>	VIN <b>22</b>				

## 15 TRAILER VIN

**DEFINITION:** This element identifies the unique combination of alphanumeric characters assigned to the specific unit as designated by the manufacturer. This manufacturer-assigned number is permanently affixed to the unit.

**RATIONALE:** Used to identify the specific design characteristics for effective evaluation. The Federal Motor Carrier Safety Administration uses this information to keep statistical records of any issues with the unit due to design or manufacturing flaws as it pertains to the safety of all users of state and interstate highways and roadways.

- The vehicle identification number (VIN) is usually a 17-digit number.
- Enter the VIN exactly as it appears on the unit or any available identifying paperwork in the “VIN” field. If unable to locate the VIN, leave the field blank.

## 16 TRAILER PLATE (SECOND TRAILING UNIT IN DOUBLES)

**DEFINITION:** This element identifies the registration information for the second trailing unit attached to the first trailing unit.

**RATIONALE:** Used to identify the registration information for the second trailer or towed vehicle and to confirm the identity of the owner/carrier.

- Trailing unit applies to any device connected to a motor vehicle by a hitch, including tractor-trailer combinations, a single-unit truck pulling a trailer, etc.
- Note:** This is not for the power unit plate. This is for the trailer or other trailing unit attached to the **first** trailing unit.
- Enter the plate number in the second “Trailer Plate” field.

## 17 TRAILER PLATE STATE/YEAR (SECOND TRAILING UNIT)

**DEFINITION:** This element identifies the state in which the second trailing unit was registered.

**RATIONALE:** Used to identify the state in which the second trailing unit was registered, for confirmation of ownership.

- Enter two-digit state abbreviation in the second “State” field.
- Enter the validation year on the sticker in the second “Year” field as this would show the most current year of registration.

## 18 TRAILER VIN (SECOND TRAILING UNIT)

**DEFINITION:** This element identifies the unique combination of alphanumeric characters assigned to the specific unit as designated by the manufacturer. This manufacturer-assigned number is permanently affixed to the unit.

**RATIONALE:** Used to identify the specific design characteristics for effective evaluation. The FMCSA uses this information to keep statistical records of any issues with the unit due to design or manufacturing flaws as it pertains to the safety of all users of state and interstate highways and roadways.

- The VIN is usually a 17-digit number.
- Enter the VIN exactly as it appears on the unit or any available identifying paperwork in the second “VIN” field. If unable to locate the VIN, leave the field blank.



Carrier Name/Lessee <b>1</b>									
Street Address <b>1</b>						City <b>1</b>		State <b>1</b>	ZIP Code <b>1</b>
Number of Axles <b>2</b>		Gross Veh. Weight Rating <b>3</b>		US DOT Number <b>4</b>			MC Number <b>5</b>		Override/Override <b>6</b>
Haz Mat Involvement <b>7</b>		Haz Mat Placard <b>8</b>	Placard Number <b>9</b>	Haz Mat Released <b>10</b>	Haz Mat Class <b>11</b>	Haz Mat Name <b>12</b>			
Trailer Plate: <b>13</b>	State <b>14</b>	Year <b>14</b>	VIN <b>15</b>						
Trailer Plate: <b>16</b>	State <b>17</b>	Year <b>17</b>	VIN <b>18</b>						
Converter Dolly <b>19</b>		Dolly Plate: <b>20</b>	State <b>21</b>	Plate Year <b>21</b>	VIN <b>22</b>				

**19 CONVERTER DOLLY**

**DEFINITION:** A small trailer that can be coupled to a truck or trailer so as to support a semitrailer. The dolly consists of a bogie equipped with a kingpin and a fifth-wheel to which the semitrailer is coupled. It is equipped with between one and three axles and is designed to connect a tow bar on the rear of the truck or trailer in front.

**RATIONALE:** This element is used to identify equipment used to tow additional units. Information is collected to link records as it pertains to maintenance and safety issues.

- Code 1**            **Yes** – dolly was used.
- Code 2**            **No** – dolly was not used.
- Code 3**            **No information/label** – used when there is no information or label or it is unreadable.
- Code 9**            **Unknown** (*explain in narrative*)



**20 DOLLY PLATE**

**DEFINITION:** This element identifies the registration information for the dolly used.

**RATIONALE:** Information needed to link records between manufacturers and owner/lesser/leasee to maintain the integrity of the equipment and its maintenance and safety records.

Enter the plate number in the “**Dolly Plate**” field.

**21 DOLLY STATE/YEAR**

**DEFINITION:** This element identifies the state in which the dolly was registered.

**RATIONALE:** Used to identify the state in which the dolly was registered, for confirmation of ownership.

- a. Enter the two-digit state abbreviation in the “**State**” field.
- b. Enter the validation year on the sticker as this would show the most current year of registration in the year field.

**22 DOLLY VIN**

**DEFINITION:** This element identifies the unique combination of alphanumeric characters assigned to the specific unit as designated by the manufacturer. This manufacturer-assigned number is permanently affixed to the unit.

**RATIONALE:** Used to identify the specific design characteristics for effective evaluation. The FMCSA uses this information to keep statistical records of any issues with the unit due to design or manufacturing flaws as it pertains to the safety of all users of state and interstate highways and roadways.

Enter the VIN exactly as it appears on the unit or any available identifying paperwork in the “**VIN**” field. If unable to locate the VIN, leave the field blank.

		2	3	4	5	6	7	8	9	10	
		Sex	Seating Position	Injury Status	Occupant Protection	Airbag Deployment	Ejection	Ejection Path	Trapped/extricated	Source of Transport	Died at scene/enroute
DRIVER OF UNIT 1	Phone Number:										
	Transported to:	Transported By:									
Name 1: 1	Phone: 1	DOB: 1	1								
Address:	Trans. to: 11	Trans. By: 12									
Name 2:	Phone:	DOB:									
Address:	Trans. to:	Trans. By:									
Name 3:	Phone:	DOB:									
Address:	Trans. to:	Trans. By:									
Name 4:	Phone:	DOB:									
Address:	Trans. to:	Trans. By:									

## INJURY SECTION

### 1 NAMES, ADDRESSES, PHONE NUMBERS, DATE OF BIRTH

You do not have to re-enter the driver’s name, gender, or their seating position since this information has already been collected above. Fields 2 thru 10 in this section **must** be filled out for the driver of the vehicle even if they are NOT injured. If possible, it is a good practice to capture this information for **all** passengers that are in the same vehicle as the driver whether they are injured or not. This creates a record for the officer of all people in the vehicle at the time of the crash. An exception to this would be passengers on a bus if they are not injured.

**DEFINITION:** All data elements for each person are needed because they describe the characteristics, actions, and consequences to persons involved in the crash. These elements include the full name, address, date of birth, and gender.

**RATIONALE:** The date element of the name is collected to facilitate future linkage to health and insurance files. The accurate reporting of the date of birth is used to assess the effectiveness of occupant protection systems for specific age groups and to identify the need for safety programs directed toward them. This element is also critical in providing linkage between the crash, emergency medical service, and hospital records. Gender is used to evaluate the effect of gender of the person involved on occupant-protection systems and motor vehicle design characteristics.

### 2 SEATING POSITION

**DEFINITION:** The location for this occupant in, on, or outside of the motor vehicle prior to the first event in the sequence of events. Describes the type of person involved in a crash.

**RATIONALE:** Need to know person type for classification purposes to evaluate specific countermeasures designed for specific people. Without known seating position for each person in the motor vehicle, it is not possible to fully evaluate, for example the effect of occupant protection programs.

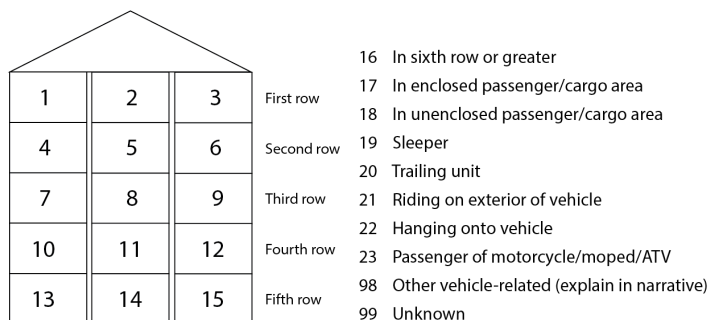

		2	3	4	5	6	7	8	9	10	
		Sex	Seating Position	Injury Status	Occupant Protection	Airbag Deployment	Ejection	Ejection Path	Trapped/extricated	Source of Transport	Died at scene/enroute
DRIVER OF UNIT 1	Phone Number:										
	Transported to:	Transported By:									
Name 1: 1	Phone: 1	DOB: 1	1								
Address:	Trans. to: 11	Trans. By: 12									
Name 2:	Phone:	DOB:									
Address:	Trans. to:	Trans. By:									
Name 3:	Phone:	DOB:									
Address:	Trans. to:	Trans. By:									
Name 4:	Phone:	DOB:									
Address:	Trans. to:	Trans. By:									

### 3 INJURY STATUS

**DEFINITION:** The injury severity level for a person involved in a crash. If an injury changes to a fatality within 720 hours of the crash, it is especially important to change the “Injury Status” and the “Died at scene/enroute” fields on the crash report and transmit the modified case to the Iowa Department of Transportation in a timely manner. This should be done for all injuries that change.

**RATIONALE:** Necessary for injury outcome analysis and evaluation. This element is also critical in providing linkage between the crash, emergency medical service, and hospital records.

**Note:** Other than code 1 “Fatal,” code 2 “Serious,” and code 7 “Fatal not crash related,” the person may refuse treatment but the attribute should be based on what was observed at the scene or indicated to the officer when interviewing everyone involved. Example: A person complains of pain but then refuses treatment, if there is nothing to indicate that it should be something more than a possible then use code 4.

#### Code 1

**Fatal** – A fatal injury is any injury that results in death within 30 days (720 hours) after the motor vehicle crash in which the injury occurred. If the person did not die at the scene but died within 30 days (720 hours) of the motor vehicle crash in which the injury occurred, the injury classification should be changed from the attribute previously assigned to the attribute “Fatal Injury.”

#### Code 2

**Suspected Serious Injury** – A suspected serious injury is any injury other than fatal which results in one or more of the following:

- Severe laceration resulting in exposure of underlying tissues/ muscle/organs or resulting in significant loss of blood
- Broken or distorted extremity (arm or leg)
- Crush injuries
- Suspected skull, chest, or abdominal injury other than bruises or minor lacerations
- Significant burns (second and third degree burns over 10% or more of the body)
- Unconsciousness when taken from the crash scene
- Paralysis

#### Code 3

**Suspected minor/non-incapacitating** – A minor injury is any injury that is evident at the scene of the crash, other than fatal or serious injuries. Examples include lump on the head, abrasions, bruises, minor lacerations (cuts on the skin surface with minimal bleeding and no exposure of deeper tissue/ muscle).

		2	3	4	5	6	7	8	9	10	
		Sex	Seating Position	Injury Status	Occupant Protection	Airbag Deployment	Ejection	Ejection Path	Trapped/extricated	Source of Transport	Died at scene/enroute
<b>DRIVER OF UNIT 1</b>		Phone Number:			Transported to:			Transported By:			
Name 1:	1	Phone:	1	DOB:	1						
Address:		Trans. to:			11			Trans. By: 12			
Name 2:		Phone:		DOB:							
Address:		Trans. to:						Trans. By:			
Name 3:		Phone:		DOB:							
Address:		Trans. to:						Trans. By:			
Name 4:		Phone:		DOB:							
Address:		Trans. to:						Trans. By:			

**Code 4 Possible (complaint of pain/injury)**  
 – A possible injury is any injury reported or claimed which is not a fatal, suspected serious, or suspected minor injury. Examples include momentary loss of consciousness, claim of injury, limping, or complaint of pain or nausea. Possible injuries are those that are reported by the person or are indicated by his/her behavior, but no wounds or injuries are readily evident.

**Code 5 Uninjured** – No apparent injury is a situation where there is no reason to believe that the person received any bodily harm from the motor vehicle crash. There is no physical evidence of injury and the person does not report any change in normal function.

**Code 7 Fatal, not crash related** – used when the vehicle fatalities that are involved in a motor vehicle crash have died from natural causes such as a stroke, heart attack, or from a homicide or suicide.

**Code 9 Unknown** – used when the person has left the scene and injury status is unknown.

**4 OCCUPANT PROTECTION**

**DEFINITION:** The restraint equipment is use by the occupant, or the helmet used by a motorcyclist at the time of the crash.

**RATIONALE:** Proper classification of the use of available occupant restraint systems and helmet use is vital to evaluating the effectiveness of such equipment.

**Code 01 Not applicable** – used when there is no restraint available in the seat position of this occupant. Use this attribute for persons who are riding in the sleeper section of the cab of a truck, for persons who are riding on the exterior of the vehicle, and for persons in unenclosed cargo areas, such as the bed of a pickup truck. This is NOT to be used for motorcycle drivers or their passengers. For motorcyclists, use **Code 2, Code 10, or Code 11.**

**Code 02 None used** – used when the occupant did not use a restraint even though it was available. An example would be a motorcyclist who did not use a helmet, or a motor vehicle driver or passenger did not use their seatbelt.

**Code 03 Shoulder and lap belt used** – used when the occupant restraint system consists of both the shoulder belt and lap belt portions and is connected to a buckle.



		1	2	3	4	5	6	7	8	9	10
		Sex	Seating Position	Injury Status	Occupant Protection	Airbag Deployment	Ejection	Ejection Path	Trapped/extricated	Source of Transport	Died at scene/enroute
<b>DRIVER OF UNIT 1</b>	Phone Number:										
	Transported to:						Transported By:				
Name 1: <b>1</b>	Phone: <b>1</b>	DOB: <b>1</b>	<b>1</b>								
Address:		Trans. to: <b>11</b>			Trans. By: <b>12</b>						
Name 2:	Phone:	DOB:									
Address:		Trans. to:			Trans. By:						
Name 3:	Phone:	DOB:									
Address:		Trans. to:			Trans. By:						
Name 4:	Phone:	DOB:									
Address:		Trans. to:			Trans. By:						

**Code 04**      **Lap belt only used** – used when the occupant is using a lap safety belt either because the motor vehicle is equipped only with a lap belt or because the shoulder belt is not in use.

**Code 05**      **Shoulder belt only used** – used for a two-part occupant restraint system and only the shoulder belt portion is connected to a buckle.

**Code 06**      **Child safety seat (forward-facing)** – used when a child passenger is seated in a forward-facing child safety seat. This does not imply correct use or placement of the seat.

**Code 07**      **Child safety seat (rear-facing)** – used when a child passenger is seated in a rearward facing child safety seat. This does not imply correct use or placement of the seat.

**Code 08**      **Child safety seat (type unknown)** – used when the investigating officer knows that some type of child restraint was in use but the type of restraint is not known.

**Code 09**      **Booster seat** – used when a child passenger is seated in a “belt-positioning seat” that positions a child on a vehicle seat to improve the fit of the child in a lap and shoulder seat belt system.

**Code 10**      **Helmet (DOT compliant)** – used a motorcycle helmet that is compliant with Federal Motor Vehicle Safety Standards. These typically weigh approximately 3 pounds, have an inner liner at least one-inch thick of firm polystyrene foam, have an inside label that states the manufacturer, model, and date of manufacture, and have a DOT sticker on the back of the helmet. A DOT sticker alone is not enough evidence to indicate that the helmet is DOT-compliant, as counterfeit stickers have been found affixed to non-compliant helmets.

**Code 11**      **Helmet (other)** – used when the motorcycle helmet was used but it could not be determined if it was DOT compliant.

**Code 98**      **Other (explain in narrative)** – used when there is some other type of restraint not listed that was being used at the time of the crash.

**Code 99**      **Unknown** – used when the vehicle has left the scene so that it is unknown what kind of restraints were used.

		2	3	4	5	6	7	8	9	10	
		Sex	Seating Position	Injury Status	Occupant Protection	Airbag Deployment	Ejection	Ejection Path	Trapped/extricated	Source of Transport	Died at scene/enroute
DRIVER OF UNIT 1	Phone Number:										
	Transported to:	Transported By:									
Name 1: 1	Phone: 1	DOB: 1	1								
Address:		Trans. to: 11			Trans. By: 12						
Name 2:	Phone:	DOB:									
Address:		Trans. to:			Trans. By:						
Name 3:	Phone:	DOB:									
Address:		Trans. to:			Trans. By:						
Name 4:	Phone:	DOB:									
Address:		Trans. to:			Trans. By:						

## 5 AIR BAG DEPLOYMENT

**DEFINITION:** This element is used to record air bag availability and deployment.

**RATIONALE:** Necessary to evaluate the effectiveness of air bags and other occupant protection equipment, especially at a time when air bags are becoming standard equipment.

**Code 01**      **Not applicable** – used when there was no air bag available for this person.

**Code 02**      **Airbag turned off** – used when there is indication that any air bag for this occupant's position was manually switched off and did not deploy.

**Code 03**      **Not deployed** – used only if the vehicle is equipped with an air bag(s) for this occupant's position, but it (they) did not deploy in the crash.

**Code 04**      **Deployed front of person** – used when driver or front-seat passenger's air bag is out of its cover and protruding into driver compartment. Bag is fully or partially deflated or inflated.

**Code 05**      **Deployed side of person** – used when air bag on side of motor vehicle is out of its cover and protruding into occupant compartment. Bag is fully or partially deflated or inflated.

**Code 06**

**Deployed both front/side** – used when more than one air bag deploys from front and side into occupant compartment. Bag is fully or partially deflated or inflated.

**Code 07**

**Deployed curtain** – used when the curtain air bag is out of its cover and protruding into driver or passenger compartment. Bag is fully or partially deflated or inflated.

**Code 98**

**Other deployment** (*explain in narrative*) – used when a knee air bag, air belt, or other new air bag technology is deployed.

**Code 99**

**Unknown** – used when this information is unavailable because the vehicle has left scene.

		2	3	4	5	6	7	8	9	10	
		Sex	Seating Position	Injury Status	Occupant Protection	Airbag Deployment	Ejection	Ejection Path	Trapped/extricated	Source of Transport	Died at scene/enroute
DRIVER OF UNIT 1	Phone Number:										
	Transported to:	Transported By:									
Name 1: 1	Phone: 1	DOB: 1	1								
Address:		Trans. to: 11			Trans. By: 12						
Name 2:	Phone:	DOB:									
Address:		Trans. to:			Trans. By:						
Name 3:	Phone:	DOB:									
Address:		Trans. to:			Trans. By:						
Name 4:	Phone:	DOB:									
Address:		Trans. to:			Trans. By:						

## 6 EJECTION

**DEFINITION:** Occupant completely or partially thrown from the interior of the motor vehicle, excluding motorcycles, as a result of a crash.

**RATIONALE:** Occupant protection systems prevent or mitigate ejections to various degrees. Analyses of the effectiveness of safety systems depend on information from this data element.

**Note:** Ejection refers to occupants being totally or partially thrown from the vehicle, including the bed of pickup trucks, during the course of the crash. This includes occupants of Jeeps, go-karts, snowmobiles, three- or four-wheel ATV/UTVs, and three wheel motorcycles, but excludes occupants of two-wheel motorcycles and mopeds.

**Code 1**      **Not applicable** – used for persons who are riding on the exterior of a vehicle or for two-wheel motorcycle or moped occupants. The exterior of the vehicle includes running boards, roof, fenders, and bumpers, but not the bed of pickup trucks, open tailgate, or boot of a convertible.

**Code 2**      **Not ejected** – used when the listed occupant was not ejected or the occupant was in a hit and run vehicle unless it is known that an ejection did occur.

**Code 3**

**Partially ejected** – used when some part but not all of an occupant’s body is, at some time during the crash, outside the occupant compartment. This does not apply to occupants who are not initially in the seating compartment of the vehicle (e.g., pickup bed, boot of a convertible, and person riding on an open tailgate), since any ejection for these would use code 4 “**Total ejected.**”

**Code 4**

**Totally ejected** – used when the occupant’s body is entirely outside the vehicle by may be in contact with the vehicle. This includes an occupant who is not initially in the seating compartment of the vehicle (e.g., pickup bed, boot of a convertible, and person riding on an open tailgate).

**Code 9**

**Unknown** – used if information is unknown.

		2	3	4	5	6	7	8	9	10	
		Sex	Seating Position	Injury Status	Occupant Protection	Airbag Deployment	Ejection	Ejection Path	Trapped/extricated	Source of Transport	Died at scene/enroute
<b>DRIVER OF UNIT 1</b>	Phone Number:										
	Transported to:	Transported By:									
Name 1: <b>1</b>	Phone: <b>1</b>	DOB: <b>1</b>	<b>1</b>								
Address:	Trans. to: <b>11</b>	Trans. By: <b>12</b>									
Name 2:	Phone:	DOB:									
Address:	Trans. to:	Trans. By:									
Name 3:	Phone:	DOB:									
Address:	Trans. to:	Trans. By:									
Name 4:	Phone:	DOB:									
Address:	Trans. to:	Trans. By:									

## 7 EJECTION PATH

**DEFINITION:** This element identifies the path by which this person was ejected from the vehicle.

**RATIONALE:** Use to analysis the projection of occupants involved in a crash for information on preventive safety measures.

This is used in conjunction with above the “Ejection” field so you cannot have a code 2 “Not ejected” and any element of codes 2 through 9.

**Code 01**      **Not ejected/Not applicable** – used when this occupant was not ejected or they are riding a two wheel motorcycle or moped.

**Code 02**      **Through front windshield** – used when this occupant was ejected either partially or completely through the front windshield.

**Code 03**      **Through side window** – used when this occupant was ejected either partially or completely through the side window.

**Code 04**      **Through side door** – used when this occupant was ejected either partially or completely through the side door.

**Code 05**      **Through roof** – used when this occupant was ejected either partially or completely through the roof.

### Code 06

**Through back window** – used when this occupant was ejected either partially or completely through the back window.

### Code 07

**Through back door/tailgate opening** – used when this occupant was ejected either partially or completely through the back door or tailgate opening.

### Code 98

**Other (explain in narrative)** – used when none of the above elements indicate the proper ejection path taken.

### Code 99

**Unknown** – used when it is unknown what the ejection path was.

## 8 TRAPPED/EXTRICATED

**DEFINITION:** This element identifies if equipment or other force was used to remove this person from the vehicle more than just lifting or carrying person out of wreckage.

**RATIONALE:** Used for analysis purposes evaluating vehicles for safety improvements in exiting a vehicle after a crash.

If an officer indicates that a person was “pinned” or “wedged” or something similar, then the officer must indicate that equipment was used to remove the occupant.

### Code 1

**Not trapped/applicable** – used when there is no extrication for this occupant. This field is not applicable to motorcycle and ATV/ATC riders.



		1	2	3	4	5	6	7	8	9	10
		Sex	Seating Position	Injury Status	Occupant Protection	Airbag Deployment	Ejection	Ejection Path	Trapped/extricated	Source of Transport	Died at scene/enroute
<b>DRIVER OF UNIT 1</b>	Phone Number:										
	Transported to:						Transported By:				
Name 1: <b>1</b>	Phone: <b>1</b>	DOB: <b>1</b>	<b>1</b>								
Address:		Trans. to: <b>11</b>			Trans. By: <b>12</b>						
Name 2:	Phone:	DOB:									
Address:		Trans. to:			Trans. By:						
Name 3:	Phone:	DOB:									
Address:		Trans. to:			Trans. By:						
Name 4:	Phone:	DOB:									
Address:		Trans. to:			Trans. By:						

**Code 2**      **Extricated by nonmechanical means**  
 – used when some non-mechanical means was used to assist occupant from being removed from vehicle without just lifting or carrying person away from vehicle.

**Code 3**      **Extricated by mechanical means** –  
 used when there was mechanical assistance to remove an occupant from vehicle such as “jaws of life” equipment.

**Code 9**      **Unknown** – used when it is unknown.

**Code 04**      **Law enforcement** – used when law enforcement officer is taking the driver or injured party to a medical facility due to injuries. This is not to be used when making tests for alcohol or drugs.

**Code 05**      **Parent/Spouse/Friend** – used when parent, spouse, or friend transports the driver or injured party for medical treatment or evaluation.

**Code 06**      **Self** – used when the driver or injured party indicates they will be driving themselves to a medical facility for treatment or evaluation.

**Code 07**      **To funeral home/morgue** – used when the driver or injured party is deceased and taken directly to a funeral home or morgue.

**Code 98**      **Other** (*explain in narrative*) – used when none of the above apply.

**Code 99**      **Unknown** – used when information is unknown such as a hit and run vehicle

## 9 SOURCE OF TRANSPORT

**DEFINITION:** Type and identity of unit providing transport to the first medical facility receiving this patient.

**RATIONALE:** Important to trace victim from the scene of crash through the health care system. Facilitates linkage of injured crash victims with emergency medical services data files.

**Code 01**      **Not transported** – used when the injured party or driver is not transported because they are not hurt or are refusing medical treatment

**Code 02**      **EMS air** – used when the driver or injured party is transported by Life Flight or some other medical air service.

**Code 03**      **EMS ground** – used when the driver or injured party is transported by ambulance or other medical ground service.

		2	3	4	5	6	7	8	9	10	
		Sex	Seating Position	Injury Status	Occupant Protection	Airbag Deployment	Ejection	Ejection Path	Trapped/extricated	Source of Transport	Died at scene/enroute
<b>DRIVER OF UNIT 1</b>	Phone Number:										
	Transported to:	Transported By:									
Name 1: <b>1</b>	Phone: <b>1</b>	DOB: <b>1</b>	<b>1</b>								
Address:		Trans. to: <b>11</b>				Trans. By: <b>12</b>					
Name 2:	Phone:	DOB:									
Address:		Trans. to:				Trans. By:					
Name 3:	Phone:	DOB:									
Address:		Trans. to:				Trans. By:					
Name 4:	Phone:	DOB:									
Address:		Trans. to:				Trans. By:					

**10 DIED AT SCENE/ENROUTE**

**DEFINITION:** This element identifies if this person died at the scene of the crash or en route to a hospital or treatment facility.

**RATIONALE:** Information is used by National Highway Traffic Safety Administration’s Fatality Analysis Reporting System (FARS) analysis.

- Code 01**      **Not applicable** – when an occupant did not die
- Code 02**      **Died at scene** – used for victims who are dead at the scene of the crash.
- Code 03**      **Died enroute** – used for victims who die on the way to a hospital or treatment facility by emergency medical service or other transport.
- Code 04**      **Died at hospital** – used for victims that die at the hospital shortly after arriving.
- Code 05**      **Died later, within 30 days (720 hrs)** – used for victims who die in the hospital before the 30 days from crash date has passed and they died from crash related injuries.
- Code 98**      **Other** (*explain in narrative*) – used when none of the above apply.
- Code 99**      **Unknown** – used when information is unknown, this should be rarely if ever used.

**11 & 12 TRANSPORTED TO AND TRANSPORTED BY**

**DEFINITION:** These are spaces to be used to indicate where the injured party has been sent to receive treatment and how they arrived at this location.

**RATIONALE:** Helps to provide linkage to the parties that provided the transportation and the treatment center that provided medical assistance.

If transported to a medical examiner, clarify what county of if to the State Medical Examiner in Ankeny.



**INVESTIGATING OFFICER'S REPORT  
OF MOTOR VEHICLE ACCIDENT**

Law Enforcement Case Number:

**MAIL REPORTS TO: Iowa Department of Transportation, Driver & Identification Services, P.O. Box 9204, Des Moines, Iowa 50306-9204**

Date of Accident	Time of Accident	County	Accident occurred within corporate limits of (city):	Legal Intervention? <b>1</b> <input type="checkbox"/>	Private Property? <b>2</b> <input type="checkbox"/>
L O C A T I O N	If accident occurred outside of city limits show general vicinity: <b>3</b> miles N NE E SE S SW W NW of nearest city			County: <b>7</b> Route: <b>8</b>	
	On Road, Street, or Highway: <b>4</b>		At intersection with: <b>5</b>	<b>9</b> X-Coordinate:	
	Note: Unless accident occurred at an intersection which is completely described above, use the space below to give the exact location from a milepost or definable intersection, bridge, or railroad crossing, using two distances and directions if necessary.			<b>10</b> Y-Coordinate:	
	Feet or Miles	N NE E SE S SW W NW	Feet or Miles	If Divided highway, Provide Route of (Cardinal) Travel Direction	
		<b>6</b>		NB	SB <b>11</b> EB WB
	Milepost Number	or	Definable intersection, bridge, or railroad crossing	<input type="checkbox"/>	<input type="checkbox"/>

**LOCATION SECTION**

**DEFINITION:** Gives the precise location where the situation became unstable.

**EXAMPLE:** If a vehicle loses control while going around a corner and hits a house, you should locate the crash at the intersection where the driver lost control, not where they hit the house. Also, this would not be a Private Property crash because it became unstable on the road.

**RATIONALE:** Allows location information to be placed and then utilized to determine if other safety features for this trafficway may need to be completed.

**Note:** Date and time of the crash do not have to be completed again, however, it is helpful when the paper form is being completed to fill out the “County” and “City” fields again as Iowa DOT staff use this information to bring up the correct county maps on their location tool.

If using TraCS Location Tool, 3-11 do not apply.

**1 LEGAL INTERVENTION** is marked only if law enforcement used some sort of force or other means to stop an eluding vehicle (i.e., ramming the vehicle or using sticks to puncture tires). When this field is used, the crash is not considered to be a crash event and neither party has a crash recorded. However, if another event occurs based on the above situation (i.e., such as someone is hurt that was not intended to be injured), other property becomes damaged, or officer loses control and sustains injury or damage, then the situation changes and becomes reportable as a crash event. Iowa law allows that if this occurs to an officer while he is in the line of duty, he can have his supervising officer complete an officer on duty form and submit it to the Iowa DOT. This form is available online.

**2 PRIVATE PROPERTY** is used when the crash occurred on private property (such as a parking lot, parking ramp, some area of a park or rest stop, farm fields, etc.). Reminder: Crashes still need to be reported to the Iowa DOT if they meet the criteria of total property damage was \$1,500 or an injury or fatality occurred. The information you provide to the department regarding these crashes may not always be used for statistical purposes but are still used for financial responsibility requirements and other departmental actions such as re-examinations and graduated driver license (GDL).

**3 IF THE CRASH OCCURRED OUTSIDE OF CITY LIMITS**, show the general vicinity by miles, give the direction from the nearest Iowa city and enter the name of that city in the “of nearest city” field.

**4 ROAD, STREET, OR HIGHWAY**

Enter the number or name of the road, street, or highway in the “On Road, Street, or Highway” field. Avoid the use of local road names that cannot be identified on a map. Indicate if the road or street does not have a number or name. For example: Enter “Unnumbered county road.”

**5 INTERSECTION**

If the crash occurred in an intersection, enter the number or name of the intersecting road, street, or highway in the “At intersection with” field.

- Railroad crossings may be shown in this space, if applicable.
- A private drive, farm drive, or business drive is not an intersection. Refer to “Intersection Definitions” on [page 87](#) for definitions and diagrams of intersections.
- If the crash occurred within an intersection of two different classes of roads, indicate that the crash happened on the higher-class road at an intersection with a lower-class road. For example: On U.S. 69 at intersection with Iowa 210, or on Iowa 210 at intersection with County Road R-14.
- If duplicate junctions are involved, indicate the proper one by an N, NE, E, SE, S, SW, W, or NW designation. For example: East and west junctions of U.S. 6 and U.S. 63.



## INVESTIGATING OFFICER'S REPORT OF MOTOR VEHICLE ACCIDENT

<b>MAIL REPORTS TO: Iowa Department of Transportation, Driver &amp; Identification Services, P.O. Box 9204, Des Moines, Iowa 50306-9204</b>				Law Enforcement Case Number:	
Date of Accident	Time of Accident	County	Accident occurred within corporate limits of (city):		
<b>L O C A T I O N</b>	If accident occurred outside of city limits show general vicinity: <b>3</b> miles		N NE E SE S SW W NW of nearest city		
	On Road, Street, or Highway: <b>4</b>		At intersection with: <b>5</b>		
Note: Unless accident occurred at an intersection which is completely described above, use the space below to give the exact location from a milepost or definable intersection, bridge, or railroad crossing, using two distances and directions if necessary.					
Feet or Miles		N NE E SE S SW W NW		Feet or Miles N NE E SE S SW W NW	
Milepost Number		Definable intersection, bridge, or railroad crossing		If Divided highway, Provide Route (Cardinal) Travel Direction	
				NB SB <b>11</b> EB WB	

### 6 EXACT LOCATION

Use the “**Feet, Miles, Milepost Number, or Definable intersection, bridge, or railroad crossing**” fields to identify the exact location of the crash unless it occurred at the intersection of numbered routes and is completely described previously.

- For crashes at complex intersections, the exact location within the intersections should be described in these fields.
- The location of non-intersection rural crashes should be identified as being a specific distance from a known point; such as an intersection of two numbered routes, a railroad crossing, major bridge, or county line, using one or more distances or directions. Do not use pavement markers, station markers, or bridge numbers.
- Non-intersection city crashes should be identified as being a specific distance (in feet) from the nearest intersection. Do not use intersection of a road and a business or residential drive. Do not use the block number of a street. For example: Do not state “100 block,” although a specific address is acceptable.
- If the specific location can be described from one or more definable points but does not fit into the blank on the form, write “See narrative” and enter the description in the “Narrative” section on the back of the form.

### 7 COUNTY

Enter the county number in the “County” field. This field is optional but should be entered if the officer has access to global positioning system (GPS) information.

### 8 ROUTE

Enter the “**Route.**” This field is optional but should be entered if the officer doesn’t have access to GPS information.

### 9 X-COORDINATE

Enter the “**x-coordinate**” of the first harmful event or where the event became unstabilized. This field is optional, but it should be entered if the officer has access to GPS information. Provide the coordinate in UTM Format – NAD83 DATUM (i.e., 0443924).

### 10 Y-COORDINATE

Enter the “**y-coordinate**” of the first harmful event or where the event became unstabilized. This field is optional, but it should be entered if the officer has access to GPS information. Provide the coordinate in UTM Format – NAD83 DATUM (i.e., 4652238).

### 11 DIVIDED HIGHWAY

If the crash occurred on a divided highway, mark the direction of the lane of travel where the first harmful event happened in the “**If Divided Highway, Provide Route (Cardinal) Travel Direction**” field. (The cardinal directions of Interstate 35 are north and south, even where the roadway is oriented east and west around Des Moines.)



ACCIDENT ENVIRONMENT			
Location of First Harmful Event	[ 1 ]	Weather Conditions	[ ] [ ]
		(up to two)	4
Manner of Crash/Collision	[ 2 ]		[ ] [ ]
Light Conditions	[ 3 ]	Surface Conditions	[ 5 ] [ ]

## ACCIDENT ENVIRONMENT SECTION

### 1 LOCATION OF FIRST HARMFUL EVENT:

**DEFINITION:** The location of the first harmful event as it relates to its position within or outside the trafficway. This should indicate when property damage or an injury first occurred.

**RATIONALE:** Important to identify highway geometric deficiencies.

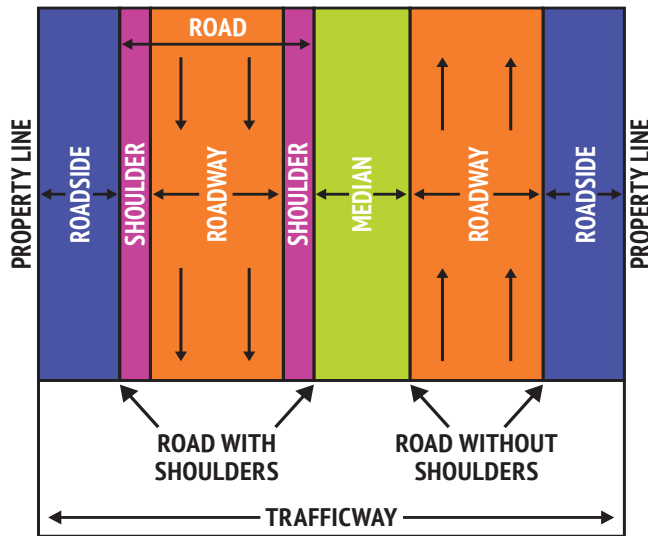

**Code 01 On roadway** – used when the roadway is that part of a trafficway designed, improved and ordinarily used for motor vehicle travel or, where various classes of motor vehicles are segregated, that part of a trafficway used by a particular class. Separate roadways may be provided for northbound or southbound traffic or for trucks and automobiles. Roadway may be noted as the travel lanes and if present, includes the area between the painted “fog lines.” Additionally, a driveway access area is considered part of the roadway of the trafficway to which it connects.

**Code 02**

**Shoulder** – used when the part of the trafficway contiguous with the roadway for emergency use, for accommodation of stopped vehicles, and for lateral support of the roadway structure. It can be paved or unpaved and on either side of the roadway. Not all roadways have shoulders.

**Code 03**

**Median** – used when it is that area of a divided trafficway between parallel roads separating travel in opposite directions. The principal function of a median is to have freedom from interference of opposing traffic, to provide a recovery area for out-of-control vehicles, to provide a stopping area in case of emergencies, and to minimize headlight glare. Medians may be depressed, raised, or flush. Flush medians can be as little as 4 feet wide between roadway edge lines. Painted roadway edge lines 4 feet or more wide denote medians. Medians of lesser width must have a barrier to be considered a median. Continuous left-turn lanes are not considered medians.

**Code 04**

**Roadside** – used when a location off the roadway, but inside the right of way. It is the outermost part of the trafficway that lays between the outer property line or other barrier and the edge of the first road encountered in the trafficway. Bicycle lanes and shared-use path or trails contiguous with the roadway and sidewalks are also included. In addition, use this attribute if the first harmful event occurs in a raised or painted center island (directional or channeling) of a traffic circle, roundabout, or junction.

ACCIDENT ENVIRONMENT			
Location of First Harmful Event	1	Weather Conditions	
		(up to two)	4
Manner of Crash/Collision	2		
Light Conditions	3	Surface Conditions	5

**Code 05**

**Gore** – used when an area of land where two roadways diverge or converge. The area is bounded on two sides by the edges of the roadway, which join at the point of divergence or convergence. The direction of traffic must be the same on both of these roadways. The area includes shoulders or marked pavement if any, between the roadways. The area is 60 meters (approximately 200 feet) from the point of divergence or convergence or, if any other road is within 70 meters (230 feet) of that point, a line 10 meters (33 feet) from the nearest edge of such road. Inclusions are areas at rest or exit ramps, areas at truck weight station entry or exit ramps, areas where two main roadways diverge or converge, areas where a ramp and another roadway or two ramps, diverge or converge or areas where a frontage road and another roadway or two frontage roads diverge or converge. Exclusions include islands for channelizing of vehicle movements and islands for pedestrian refuge. Used for areas not open to the public as a matter of right or custom for moving persons or property. This includes property beyond the roadside outside the boundaries of the trafficway. A portion of the trafficway closed for construction is not a trafficway and would be considered as outside trafficway.

**Code 06**

**Outside Trafficway** – used for areas not open to the public as a matter of custom for moving persons or property. This includes property beyond the boundaries of the trafficway. This would include a portion of the trafficway closed for construction, and crashes that occur on private property such as parking lots.

**Code 07**

**In parking lane/zone** – used when an area on the roadway, or next to the roadway, on which parking is permitted in marked or unmarked spaces. This includes curbside and edge of roadway parking (e.g., legal residential parking, city-street parking, etc.). Sometimes a strip of roadway can be designated for parking at certain hours of the day (parking lane) and for regular travel at other hours (travel lane). This code should not be used during hours when parking is not permitted.

**Code 08**

**Continuous left-turn lane** – used when a two-way, left-turn lane positioned between opposing straight through travel lanes.

**Code 09**

**Separator** – used when an area of a trafficway between parallel roads separating travel in the same direction or separating a frontage road from other roads. This may be a physical barrier or a depressed, raised, flush, or vegetated area between roads.

**Code 98**

**Other** (*explain in narrative*) – used for other situation not covered with the existing attributes listed above.

**Code 99**

**Unknown** – used when officer is unable to determine exactly where the crash for first harmful event occurred. Should rarely be used as even if the vehicle left the scene it is still possible to know where the crash occurred.

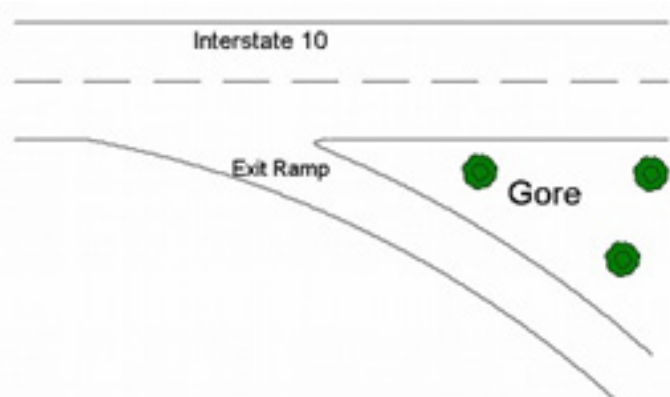

ACCIDENT ENVIRONMENT			
Location of First Harmful Event	[ 1 ]	Weather Conditions	[ ] [ ]
Manner of Crash/Collision	[ 2 ]	(up to two)	[ 4 ] [ ]
Light Conditions	[ 3 ]	Surface Conditions	[ 5 ] [ ]

## 2 MANNER OF CRASH/COLLISION

**DEFINITION:** The identification of the manner in which two motor vehicles initially came together without regard to the direction of force. This data element refers only to crashes where the first harmful event involves a collision between two motor vehicles. If there is only one vehicle involved, then it is classified as a non-collision (single vehicle). Bicycle, pedestrian, and horse and buggy crashes would be considered as non-collision crashes because they are not considered units and should be recorded in the “Non-motorist” section, not in the “Unit” section.

**RATIONALE:** Important for evaluation of occupant injuries and structural defects. This data element can be used in conjunction with motor vehicle action, points of impact, and direction of travel to describe the crash.

### Code 01

**Non-collision (single vehicle)** – used when the first harmful event is not an impact between two in-transport motor vehicles. Bicycles and horse/buggy are not considered motor vehicles (see listing for non-motorists) so this attribute should be used when they are involved.

### Code 02



**Head-on (front to front)** – used when a collision occurs between the front end of one vehicle and the front end of another vehicle. The direction of travel for each vehicle should be opposite (N/S or E/W) and the points of impact must both be front.

### Code 03

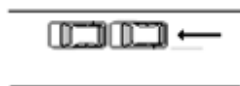

**Rear-end (front to rear)** – used when a collision occurs between the rear of one vehicle and the front of another vehicle. If this attribute is selected, the points of impact for the vehicles involved in the first harmful event must be front to back and direction of travel for both vehicles should be the same (N/N, S/S, E/E, W/W).

### Code 04

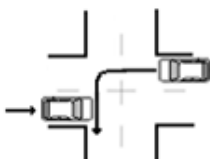

**Angle (oncoming left turn)** – used when one vehicle is making a left-hand turn and another vehicle is going straight. The direction of travel should be opposite (N/S, E/W with at least one vehicle making a left-hand turn).

### Code 05

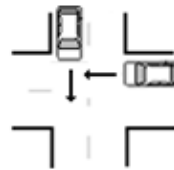

**Broadside (front to side)** – used when impact is made in the side of vehicle and the direction of travel is at the next compass point (N/W, N/E, S/W, S/E). One of the vehicles should have damage to the front of their vehicle and the other vehicle along the side.

### Code 06



**Sideswipe (same direction)** – used when the two vehicles were traveling in the same direction and the impact is made along the side of the vehicles.

### Code 07



**Sideswipe (opposite direction)** – used when the vehicles were traveling in opposite directions and the impact is made along the side of the vehicles.

### Code 08

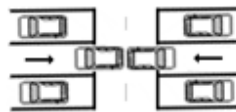

**Rear to rear** – used when the rear of one vehicle hits the rear of another vehicle so that the points of impact both must be back. Usually occurs when one or more vehicles are backing up.

### Code 09

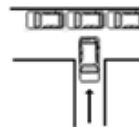

**Rear to side** – used when a collision occurs between the rear of one vehicle and the side of another vehicle. If this attribute is selected, the points of impact for the vehicles involved in the first harmful event must back for one and side for the other.

### Code 98

**Other (explain in narrative)** – used when none of the above attributes fit the event and should be reported in the narrative in detail to help explain the situation.

### Code 99

**Unknown** – used when it is not known such as the vehicle has left the scene and there are no witnesses to indicate what the vehicle was doing.

ACCIDENT ENVIRONMENT			
Location of First Harmful Event	[ 1 ]	Weather Conditions	[ ] [ ]
Manner of Crash/Collision	[ 2 ]	(up to two)	[ 4 ] [ ]
Light Conditions	[ 3 ]	Surface Conditions	[ 5 ] [ ]

### 3 LIGHT CONDITIONS

**DEFINITION:** The type/level of light that existed at the time of the motor vehicle crash (see [Appendix G on page 108](#) for light condition table).

**RATIONALE:** Important for management/administration and evaluation. This is critical for prevention programs and engineering evaluations.

- Code 1**      **Daylight** – used when the incident is during the daylight hours.
- Code 2**      **Dusk** – used when the incident is during the transition period going from a daylight condition to the “dark of night.” This is typically the 30-minute period after the sun sets.
- Code 3**      **Dawn** – used when the incident is during the transition period going from “dark of night” to a daylight condition. This is typically the 30-minute period before the sun rises.
- Code 4**      **Dark, roadway lighted** – used when there is no natural light exists but there is overhead man-made lighting on the roadway where the crash occurs. Lighted areas will generally include streets within cities or towns and some interchange areas. This does not include lighting from store fronts, houses, parking lots, etc.
- Code 5**      **Dark, roadway not lighted** – used when the condition is that there is no natural light and no overhead man-made lighting is present on the roadway where the crash occurred.
- Code 6**      **Dark, unknown roadway lighting** – used when the crash occurred at night but it is unknown about the roadway lighting.
- Code 9**      **Unknown** – used when it is unknown what hour the crash occurred so that a determination of lighting is not possible.

### 4 WEATHER CONDITION (UP TO TWO MAY BE USED)

**DEFINITION:** The prevailing atmospheric conditions that existed at the time of the crash.

**RATIONALE:** Important for management/administration and evaluation. This is critical for prevention programs and engineering evaluations.

- Code 01**      **Clear** – used when the sky is clear but also includes partial cloudiness if sunlight is not diminished.
- Code 02**      **Cloudy** – used when the sky is “overcast” but may include partial cloudiness if light is diminished.
- Code 03**      **Fog, smoke, smog** – used when a natural or man-made condition causes reduced visibility.
- Code 04**      **Freezing rain/drizzle** – used when precipitation is falling as liquid (rain) and then freezing on the roadway.
- Code 05**      **Rain** – used when the precipitation falling is other than snow, hail, or sleet.
- Code 06**      **Sleet, hail** – used when the precipitation falling is ice.
- Code 07**      **Snow** – used when the precipitation falling is snow.
- Code 08**      **Blowing snow** – used when snow that is falling and/or to snow that has fallen to the ground and is set aloft by wind. Use this code for blizzard like conditions.
- Code 09**      **Severe winds** – used when winds traveling at an angle with respect to the travel lanes at velocities significant enough to create a risk because vehicles could be diverted from their path or high-profile vehicles could be blown over. These are winds that are strong enough to affect vehicle stability.

ACCIDENT ENVIRONMENT			
Location of First Harmful Event	1		Weather Conditions
Manner of Crash/Collision	2		(up to two)
Light Conditions	3		Surface Conditions

- Code 10**      **Blowing sand, soil, dirt** – used when particulate matter set aloft by winds creating a condition of reduced visibility that constitutes a hazard for vehicles operating in the area. This attribute should be used for “dust storms” but should not be used in conjunction with severe winds unless the winds are affecting vehicle stability in addition to reducing visibility.
- Code 98**      **Other** (*explain in narrative*) – used when none of the above attributes fit the condition.
- Code 99**      **Unknown** – used when it is not known what the condition was at the time of the crash such as a hit and run crash with no witnesses or idea of what time the crash occurred.

- Code 03**      **Ice/Frost** – used when the roadway is covered with ice from freezing rain or water runoff that has pooled on the roadway and turned to ice.
- Code 04**      **Snow** – used when the roadway surface is covered with snow.
- Code 05**      **Slush** – used when the roadway surface is covered with melting snow.
- Code 06**      **Mud, dirt** – used when these substances were present on the surface of the roadway at the crash location, not the surface type of the roadway by design.
- Code 07**      **Water (standing or moving)** – used when the roadway surface that is covered with water and typically localized.

## 5 SURFACE CONDITION

**DEFINITION:** The roadway surface condition at the time and place of a crash.

**RATIONALE:** Important to identify and correct high wet-surface crash locations and provide information for setting coefficient of pavement friction standards. This is critical for prevention programs and engineering evaluations.

**Note:** For vehicles departing the trafficway prior to their critical events, the trafficway selected for classification is the one the vehicle departed. If this vehicle is in a junction just prior to its critical event, the roadway selected for classification is the one it is on before entering the junction. These conditions may have been present but did not necessarily contribute to the crash.

- Code 01**      **Dry** – used when the road in normal conditions. Code “**Dry**” when the road is made of any material, including sand or dirt, if it is in normal conditions.
- Code 02**      **Wet** – used when the roadway surface that is covered with water from rain or melted snow.

- Code 08**      **Sand** – used when sand is on the roadway as a result of sand blown by wind or sand discharged on the roadway by highway trucks.
- Code 09**      **Oil** – used when oil is on the roadway, includes fuel spilled on the roadway.
- Code 10**      **Gravel** – used when gravel is present on the surface of the roadway at the crash location, not the surface type of the roadway by design (not a gravel road).
- Code 98**      **Other** (*explain in narrative*) – used when none of the above attributes fit the situation.
- Code 99**      **Unknown** – used when it is unknown the condition of the surface at the time of the crash because it is unknown when the actual crash occurred and there are no witnesses.



ROADWAY CHARACTERISTICS	
Major Contributing Circumstances	
Environment	1 <input type="text"/>
Roadway	2 <input type="text"/>
Type of Roadway Junction/Feature	3 <input type="text"/>
FRA #:	4 <input type="text"/> <input type="text"/> <input type="text"/> <input type="text"/> <input type="text"/> <input type="text"/> <input type="text"/> <input type="text"/>

## ROADWAY CHARACTERISTICS SECTION

### 1 ENVIRONMENT

**DEFINITION:** Apparent environmental conditions that may have contributed to the crash.

**RATIONALE:** Important to determine existence of unusual conditions that could be useful in determining the need for additional traffic control devices or geometric improvements.

- Code 01**      **None apparent** – used when there is no apparent environmental circumstance.
- Code 02**      **Weather conditions** – used when there is an indication that environmental conditions recorded in “**Weather Conditions**” field contributed to the crash. Ensure that if you put weather as a factor here, you make sure that you have something other than code 1 “**Clear**” or code 2 “**Cloudy**” as neither of these would have an adverse effect on driving.
- Code 03**      **Visual obstruction** – used when an object that blocked the driver’s sign contributed to the crash such as a bush, tree, etc.
- Code 04**      **Non-motorist action** – used when the actions of a pedestrian, pedal cyclist, or other non-motorist such as persons riding on an animal, or in an animal drawn conveyance, or on a personal conveyance causes the driver to crash. Contact does not have to be made for this attribute to be used.
- Code 05**      **Glare** – used when a very harsh bright, dazzling light impairs the driver’s vision and can be from a motor vehicle (headlights or shining off of some part of the vehicle) or natural light (sunlight, reflection from snow, etc.)

**Code 06**

**Animal in roadway** – used when an animal is in the roadway and would include live wild or domestic animals but would exclude animals pulling a conveyance or ridden animals as they would be classified as non-motorist. Contact does not have to be made to use this attribute.

**Code 07**

**Severe crosswinds** – used when there is a crosswind that is severe enough to impact driving. This is not related to weather conditions with strong winds but more of a natural element of the roadway (i.e., roadway is located at a dip in which the least amount of wind causes a rush of air to flow around the vehicle making it difficult to keep vehicle in control).

**Code 98**

**Other** (*explain in narrative*) – used when none of the other attributes can be used.

**Code 99**

**Unknown** – used when it is unknown.

### 2 ROADWAY

**DEFINITION:** Apparent condition of the road that may have contributed to the crash.

**RATIONALE:** Important to determine highway maintenance and possible engineering needs.

**Code 01**

**None apparent** – used when there is no indication there was a contributing circumstance in this crash related to the road/roadway.

**Code 02**

**Surface condition (e.g., wet, icy)** – used when the road surface condition was wet, icy, snow, slush, etc., that contributed to the crash. Note that weather condition and surface condition should also have an element other than clear or dry.

ROADWAY CHARACTERISTICS	
Major Contributing Circumstances	
Environment	1
Roadway	2
Type of Roadway Junction/Feature	3
FRA #:	4

**Code 03**

**Debris** – used when an object(s) in the roadway may have contributed to the crash, such as cardboard boxes, trash or vehicle parts, animal carcasses, nails, glass, barricades, piles of sand, or other materials that have fallen from another vehicle. Note: These would be objects in the roadway that are not large enough to block travel but could cause damage or a loss of control.

**Code 04**

**Ruts, holes, bumps** – used when there is an irregular roadway surface, either concave in the case of ruts and holes or convex in the case of bumps.

**Code 05**

**Work zone (roadway-related)** - used when an area of a trafficway where construction, maintenance, or utility work activities are identified by warning signs/signals/indicators, including those on transport devices (e.g., signs, flashing lights, channelizing devices, barriers, pavement markings, flagmen, warning signs, and arrow boards mounted on the vehicles in a mobile maintenance activity) that mark the beginning and end of a construction, maintenance, or utility work activity. It extends from the first warning sign, signal, or flashing lights to the “End Road Work” sign or the last traffic control device pertinent for that work activity. Work zones also include roadway sections where there is ongoing, moving (mobile) work activity such as lane line painting or roadside mowing only if the beginning of the ongoing, moving (mobile) work activity is designated by warning signs or signals. If this attribute is used, then the “**Work Zone**” field should also be completed.

**Code 06**

**Slippery, loose or worn surfaces** – used when the road surface is well used, often very smooth or shiny in appearance or a loose gravel roadway (i.e., slippery or old worn blacktop, newly paved surface, loose gravel roadway).

**Code 07**

**Obstruction in roadway** – used when there is a blockage in the roadway, such as that caused by a fallen tree or a large boulder.

**Code 08**

**Traffic control obscured** – used when the traffic control is covered or faded and would include lane markings faded, signs that are down or covered by foliage, etc.

**Code 09**

**Shoulders (none, low, soft, high)** – used when the shoulders or the lack of having shoulders contributes to the crash. The shoulder is the part of a trafficway contiguous with the roadway for emergency use, for accommodation of stopped motor vehicles and for lateral support of the roadway structure.

**Code 10**

**Non-highway work** – used when there is maintenance or other types of work occurring near or in the trafficway but not related to the trafficway. This would not be a work zone situation, but an example would include work on replacing a pole or the wires/lines.

**Code 11**

**Traffic backup, prior crash** – used when the accumulation of traffic caused by vehicles slowing or stopping the traffic flow. Note this attribute is only used for prior traffic crashes. The distance from the prior crash does not matter, just its relevance to this crash.

ROADWAY CHARACTERISTICS	
Major Contributing Circumstances Environment	1 <input type="text"/>
Roadway	2 <input type="text"/>
Type of Roadway Junction/Feature	3 <input type="text"/>
FRA #:	4 <input type="text"/> <input type="text"/> <input type="text"/> <input type="text"/> <input type="text"/> <input type="text"/> <input type="text"/> <input type="text"/>

- Code 12**      **Traffic backup, regular congestion** – used when the accumulation of traffic is caused by vehicles slowing or stopping the traffic flow and pertains to daily traffic volume congestion issues. This could occur any day of the week, but typically would occur during peak work travels periods in the morning and evening.
- Code 13**      **Traffic backup, prior nonrecurring incident** – used when accumulation of traffic caused by vehicles slowing or stopping the traffic flow and would include a funeral procession, a sporting event or other gathering, a parade, a traffic signal outage, etc.
- Code 14**      **Disabled vehicle** – used when accumulation of traffic caused by vehicles slowing or stopping the traffic flow due to a stalled or disabled vehicle.
- Code 98**      **Other** – used when none of the above attributes cover the situation and needs to be clarified in the narrative.
- Code 99**      **Unknown** – used when the information is not known.
- Code 02**      **Bike lanes** – used when a part of the road that is marked off or separated for the use of bicyclists, not to be confused with bike trails that intersect with roadways as these would be coded 17 “**Intersection related shared-use path or trail.**”
- Code 03**      **Railroad grade crossing** – used when the first harmful event occurred at an intersection between a roadway and train tracks that cross each other at the same level (grade). Crashes occurring outside a railway grade crossing due to traffic congestion associated with a railway grade crossing are considered as code 1 “**Non-junction.**”
- Code 04**      **Driveway access (within)** – used when the first harmful event occurs on a driveway access or involves a road vehicle entering or leaving by way of a driveway access where at least one traffic unit or non-motorist is physically on the driveway access within the trafficway. This attribute includes crashes occurring on sidewalks within the driveway access. A driveway is outside the trafficway and is typically not provided an official identification name or number. Examples: A car turning into a private residence driveway strikes a bicyclist riding on the sidewalk that crosses over the driveway access, or a tractor-trailer backing out of a business entrance onto the trafficway, while partially on the driveway access, is struck by a car on the roadway.

### 3 TYPE OF ROADWAY JUNCTION/FEATURE

**DEFINITION:** The coding of this data element is based on the location of the first harmful event of the crash; it identifies the crash’s location with respect to presence in a junction or proximity to components typically in junction or interchange area.

**RATIONALE:** Important for site-specific safety studies to identify locations with actual or potential problems.

#### A. NON-INTERSECTIONS

- Code 01**      **Non-junction/No special feature** – used when crashes where the first harmful event occurs outside an interchange area and does not occur in or related to a junction, ramp, rail grade crossing, crossover, or shared-use path or trail. This attribute

ROADWAY CHARACTERISTICS	
Major Contributing Circumstances	
Environment	1 <input type="checkbox"/>
Roadway	2 <input type="checkbox"/>
Type of Roadway Junction/Feature	3 <input type="checkbox"/>
FRA #: 4	<input type="checkbox"/> <input type="checkbox"/> <input type="checkbox"/> <input type="checkbox"/> <input type="checkbox"/> <input type="checkbox"/> <input type="checkbox"/>

**Code 05**      **Driveway access (related, not in)** – used when the first harmful event occurs on the trafficway but does not occur on a driveway access but results from an activity, behavior, or control related to the movement of traffic units onto or out of a driveway. Examples: A vehicle attempting to turn left into a driveway from the eastbound lanes is struck broadside by another vehicle traveling in the westbound lanes, or a vehicle that has just entered the trafficway from a driveway is struck in the rear before it can gain speed. Note: When a driveway access junction is within the boundaries of the intersection it should be coded as intersection related and have one of the codes from 10 through 18.

**Code 06**      **Alley** – used when the first harmful event occurs on a narrow street or passageway between or behind city or residential buildings.

**Code 07**      **Crossover-related** – used when the crash is located in the area of the median of a divided trafficway where motor vehicles are permitted to cross the opposing lanes of traffic or do a U-turn. The crash has to be related to the use of the crossover.

**Code 96**      **Other non-intersection** (*explain in narrative*) – used when none of the above attributes fit the description of the roadway.

**B. INTERSECTION-RELATED**

**DEFINITION:** An intersection consists of two or more roadways that intersect at the same level.

**RATIONALE:** Important for site-specific safety studies to identify actual or potential safety problem locations.

**Code 10**      **Roundabout** – used when there are circular traffic patterns in which yield control is used on all entries,

circulating vehicles have the right of way, pedestrian access is allowed only across the legs of the roundabout behind the yield line and circulation is counter-clockwise and passes to the right of the central island.

**Code 11**      **Traffic circle** – used when there is an intersection of roads where motor vehicles must travel around a circle to continue on the same road or leave on any intersecting road.

**Code 12**      **Four-way intersection** – used when there are two roadways cross or connect.

**Code 13**      **T-intersection** – used when an intersection where two roadways connect in a perpendicular manner and one roadway does not continue across the other roadway. The roadways form a “T.”

**Code 14**      **Y-intersection** – used when an intersection where three roadways connect and none of the roadways continue across the other roadways. The roadways form a “Y.”

**Code 15**      **Five points or more** – used when the intersection is where more than two roadways cross or connect.

**Code 16**      **L-intersection** – used when there is a two-armed intersection in which one road intersects with another road but neither road extends beyond the other road

**Code 17**      **Shared-use path or trail** – used when a bikeway physically separated from motorized vehicular traffic by an open space or barrier. Shared-used paths will also be used by pedestrians, skaters, wheelchairs, joggers, and other nonmotorized users.

ROADWAY CHARACTERISTICS	
Major Contributing Circumstances	
Environment	1 <input type="checkbox"/>
Roadway	2 <input type="checkbox"/>
Type of Roadway Junction/Feature	3 <input type="checkbox"/>
FRA #:	4 <input type="checkbox"/> <input type="checkbox"/> <input type="checkbox"/> <input type="checkbox"/> <input type="checkbox"/> <input type="checkbox"/>

**Code 18** **Intersection with ramp** – used when an area that contains a crossing or connection of two or more roadways with one of the roadway being classified as a ramp.

**Code 97** **Other intersection** (*explain in narrative*) – used when none of the other attributes above apply.

C. INTERCHANGE-RELATED

**DEFINITION:** The coding of this data element is based on the location of the first harmful event of the crash. It identifies the crash’s location with respect to presence in an interchange area.

**RATIONALE:** Important for site-specific safety studies to identify locations with actual or potential problems.

**Code 20** **On-ramp, merge area** – used when the first harmful event occurs on the roadway in an interchange area on an auxiliary or speed-change lane that allows vehicles to accelerate to highway speeds before entering the through roadway.

**Code 21** **Off-ramp, diverge area** – used when the first harmful event occurs on the roadway in an interchange area on an auxiliary or speed-change lane that allows vehicles to decelerate to safe speeds to negotiate a ramp without interrupting traffic flow on the through roadway existed.

**Code 22** **On-ramp** (also known as an entrance ramp) – used when the crash occurs on an approach to a roadway.

**Code 23** **Off-ramp** (also known as an exit ramp) – used when the crash occurs on an exit of a roadway.

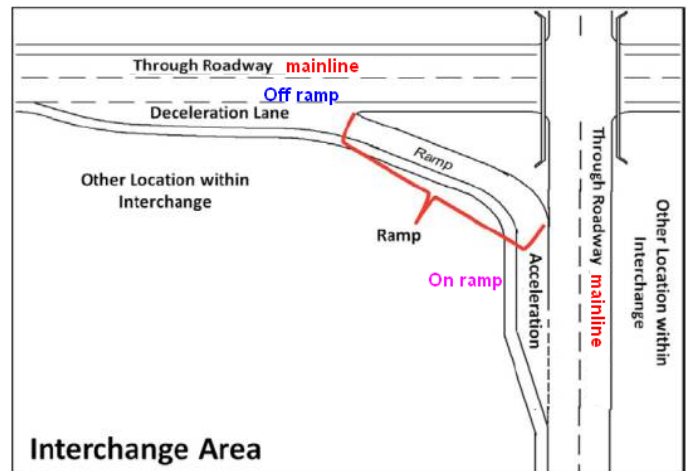

**Code 24** **Mainline, between ramps** – used when the crashes is in an interchange area and it does not occur: 1) on an entrance/exit ramp; or 2) in an intersection or related to an intersection or other junction.

**Code 98** **Other interchange** (*explain in narrative*) – used when none of the other attributes apply.

**Code 99** **Unknown** – used when the information is not known.

4 FRA NO.

**DEFINITION:** Each highway-railroad crossing is assigned a unique identifier – a U.S. DOT National Highway-Rail Crossing Inventory Program’s inventory number, normally referred to as a Federal Railroad Administration number. The number consists of six digits followed by a letter and is posted on a metal plate at each crossing.

**RATIONALE:** Is used to identify crashes to the Iowa DOT’s Office of Rail Transportation for purposes of evaluating any safety features that may be needed.

**Note:** This will only be used when there is a crash between a train and a motor vehicle.



First Harmful Event (Crash) 1	WORKZONE RELATED? 2	Yes No <input type="radio"/> <input checked="" type="radio"/>	Activity 3	Location 4	Type 5	Workers Present 6
----------------------------------	------------------------	--	---------------	---------------	-----------	----------------------

## FIRST HARMFUL EVENT/WORK ZONE-RELATED SECTION

### 1 FIRST HARMFUL EVENT (CRASH)

**DEFINITION:** The first event in the crash that caused damage or an injury. See note\*, none of these events would actually cause damage or injury but only are leading up to the collision event.

**RATIONALE:** Needed for uniformity in reported motor vehicle crash statistics, understanding crash causation, and identifying possible crash avoidance countermeasures.

Codes are listed for this field in [“Sequence of Events”/“Most Harmful Event.”](#)

\***Note:** Do not use the pre-crash events coded as 1 through 13, except for 8, in the [“Sequence of Events/Most Harmful”](#) field as these are only events that occurred prior to the event that created damage or injury.

**RATIONALE:** Important to assess the impact on traffic safety of various types of on-highway work activity, to evaluate Traffic Control Plans used at work zones, and to make adjustments to Traffic Control Plans for the safety of workers and the traveling public. This data element needs to be collected at the scene because work zones are temporary or moving operations that are not recorded in permanent road inventory files.

### 2 WORK ZONE CRASH

**DEFINITION:** A motor vehicle traffic crash in which the first harmful event occurs within the boundaries of a work zone or on an approach to or exit from a work zone, resulting from an activity, behavior, or control related to the movement of the traffic units through the work zone.

Select Yes or No in this field.

### WORK ZONE-RELATED

**DEFINITION:** A crash that occurs in or related to a construction, maintenance, or utility work zone, whether or not workers were actually present at the time of the crash. “Work zone-related” crashes may also include those involving motor vehicles slowed or stopped because of the work zone, even if the first harmful event occurred before the first warning sign. See [Appendix F on page 107](#) to see a diagram of a work zone area.

**RATIONALE:** Important to assess the impact on traffic safety of various types of on-highway work activity, to evaluate traffic control plans used at work zones, and to make adjustments to traffic control for the safety of workers and the traveling public. This data element needs to be collected at the scene because work zones are temporary or moving operations that are not recorded in permanent road inventory files.

### 3 WORK ZONE ACTIVITY

**Code 01 Construction** – used when there is long-term stationary construction such as building a new bridge, adding travel lanes to the roadway, extending an existing trafficway, etc. Highway construction includes construction of appurtenances such as guardrails or ditches, surveying activity, installation of utilities within the right of way, etc.

**Code 02 Maintenance** – used when there is work activities, including moving work activities, such as striping the roadway, median, and roadside grass mowing/landscaping, pothole repair, snowplowing, etc., where there are warning signs or signals marking the beginning of the moving work area.

**Code 03 Utility** – used when there is a short-term stationary work such as repairing/maintaining electric, gas, water lines, or traffic signals. The utility company must perform the work.

**Code 98 Other** (*explain in narrative*) – used when none of the above attributes describe the activity.

**Code 99 Unknown** – used when the information is not known because an officer did not investigate at the scene.

### WORK ZONE

**DEFINITION:** An area of a trafficway where construction, maintenance, or utility work activities are identified by warning signs/signals/indicators, including those on transport devices (e.g., signs, flashing lights, channelizing devices, barriers, pavement markings, flagmen, warning signs, and arrow boards mounted on the vehicles in a mobile maintenance activity) that mark the beginning and end of a construction, maintenance, or utility work activity. It extends from the first warning sign, signal, or flashing lights to the “End Road Work” sign or the last traffic control device pertinent for that work activity. Work zones also include roadway sections where there is ongoing, moving (mobile) work activity such as lane line painting or roadside mowing only if the beginning of the ongoing, moving (mobile) work activity is designated by warning signs or signals.

First Harmful Event (Crash) 1	WORKZONE RELATED? 2	Yes No C 2 O	Activity 3	Location 4	Type 5	Workers Present 6
----------------------------------	------------------------	-----------------	---------------	---------------	-----------	----------------------

## 4 LOCATION

**DEFINITION:** The exact location in a construction, maintenance, or utility work zone.

**RATIONALE:** Important to assess the impact on traffic safety of various types of on-highway work activity, to evaluate traffic control plans used at work zones, and to make adjustments to traffic control plans for the safety of workers and the traveling public. This data element needs to be collected at the scene because work zones are temporary or moving operations that are not recorded in permanent road inventory files.

- Code 01**      **Before work zone warning sign** – used when occurring in an area before the start of the actual marked work zone. This attribute applies when the “First Harmful Event” of the crash occurs outside (before) the first warning sign, signal, or indicator marking the start of the work zone but is related to the movement of the traffic units through or entry into the work zone area.
- Code 02**      **Advance warning area** – used when in the area within a work zone where motorists are warned of changes in the flow of traffic as a result of the work zone. This attribute applies when the first harmful event of the crash occurs inside the work zone (after) the first warning sign, signal, or indicator marking the start of the work zone but before any change in the flow of traffic by restriction, re-routing, or closure of travel lanes. Not all work zones will have advance warning areas.
- Code 03**      **Transition area** – used when in the area within a work zone where motorists are transitioned from the normal flow of traffic as a result of the work zone. This attribute applies when the first harmful event of the crash occurs inside the work zone in the area where the flow of traffic is modified by restriction, re-routing, or closure of travel lanes before entering the location where the work activity is taking place. Not all work zones will have transition areas.

### Code 04

**Within or adjacent to work activity** – used when located adjacent to actual work area, whether workers and equipment were present or not. Note: This is the area within a work zone where the work activity associated with the marked work zone takes place. This attribute applies when the first harmful event of the crash occurs inside the work zone in the area where the work activity is taking place. All work zones will have activity areas.

### Code 05

**Termination area** – used when in the area within a work zone where motorists are transitioned from the modified flow of traffic in the work zone back to the normal flow of traffic for the trafficway. This attribute applies when the first harmful event of the crash occurs inside the work zone in the area where motorists are transitioned back to the normal flow of traffic or outside the work zone (i.e., beyond the “End Road Work” sign if present) but is related to the movement of the traffic units exiting the work zone.

### Code 98

**Other** (*explain in narrative*) – used when none of the above attributes apply.

### Code 99

**Unknown** – used when this information is unknown.

First Harmful Event (Crash) 1	WORKZONE RELATED? 2	Yes No C 2 O	Activity 3	Location 4	Type 5	Workers Present 6
----------------------------------	------------------------	-----------------	---------------	---------------	-----------	----------------------

**5 TYPE**

**DEFINITION:** Work zone includes lane closure; lane shift/crossover; work on shoulder or median; intermittent or moving related to a construction, maintenance, or utility work zone, whether or not workers were actually present at the time of the crash.

**RATIONALE:** Important to assess the impact on traffic safety of various types of on-highway work activity, to evaluate traffic control plans used at work zones, and to make adjustments to traffic control plans for the safety of workers and the traveling public. This data element needs to be collected at the scene because work zones are temporary or moving operations that are not recorded in permanent road inventory files.

**6 WORKERS PRESENT**

- Code 01 Workers only
- Code 02 No workers present
- Code 03 Workers and officer present
- Code 04 Law enforcement present only
- Code 05 No one present
- Code 98 Other (*explain in narrative*)
- Code 99 Unknown

**Code 01 Lane closure** – used when in a work zone where the work activity results in the closure of a travel lane in one direction resulting in the re-routing of vehicles to a different lane for travel in that direction.

**Code 02 Lane switch/crossover** – used when in a work zone where the work activity results in the re-routing of vehicles through a lane shift where the number of lanes is maintained and those lanes are shifted several feet to one side to enable more workspace by using the shoulder to carry traffic.

**Code 03 Work on shoulder or median** – used when in a work zone where the work activity is occurring on the shoulder or median adjacent to the travel lanes. This type of work zone would not require a closure of a lane or shift of vehicle travel.

**Code 04 Intermittent or moving work** – used when in a work zone where the work activity involves the construction vehicles traveling (moving) along the trafficway and either stopping periodically to perform work (e.g., pothole patching) or performing slow-moving operations (e.g., pavement marking convoys).

**Code 98 Other** (*explain in narrative*) – used when none of the above apply.

**Code 99 Unknown** – used when information is unknown.

NO NM OT OR IS TS	Name 1:			Phone Number:	Date of Birth:	Sex	Struck by Unit #	Injury Status	Non-Motorist Type	Location (prior to impact)	Action (prior to crash)	Condition	Safety Equipment	Contributing Circumstances	Source of Transport	Died at Scene/Enroute
	Address:			Alcohol Test Given	Test Results:	Drug Test Given / Result	Charged: Yes No									
Transported to:				Transported By:												
Name 2:			Phone Number:	Date of Birth:												
Address:			Alcohol Test Given	Test Results:	Drug Test Given / Result	Charged: Yes No										
Transported to:				Transported By:												

## NON-MOTORIST SECTION

**DEFINITION:** This section is to be used for all non-motorists who have been injured or died.

**RATIONALE:** Important for management/administration and evaluation. Needed to determine number and type of non-motorists injured or killed in crashes.

Fields that need to be completed and instructions to do so are found elsewhere in this manual.

- Name ([page 7, Driver information](#))
- Address ([page 7, Driver information](#))
- Phone number
- Date of birth ([page 7, Driver information](#))
- Sex ([page 7, Driver information](#))
- Transported to ([page 56, Injury section](#))
- Transported by ([page 56, Injury section](#))
- Alcohol test given ([page 9, Driver information](#))
- Test results ([page 9, Driver information](#))
- Drug test given ([page 9, Driver information](#))
- Drug test results ([page 9, Driver information](#))
- Injury status ([page 49, Injury section](#))
- Source of transport ([page 55, Injury section](#))
- Died at scene/enroute ([page 56, Injury section](#))

Refer to earlier sections on how to complete these fields

N O	Name 1:	Phone Number:	Date of Birth:	Sex	Struck by Unit #	Injury Status	Non-Motorist Type	Location (prior to impact)	Action (prior to crash)	Condition	Safety Equipment	Contributing Circumstances	Source of Transport	Died at Scene/Enroute
					1	2	3	4	5	6	7	8		
NM O T O	Address:		Alcohol Test Given	Test Results:	Drug Test Given / Result		Charged: Yes No							
			<input type="checkbox"/>				<input type="radio"/> <input type="radio"/>							
R I S T S	Transported to:			Transported By:										
S T S	Name 2:	Phone Number:	Date of Birth:											
	Address:		Alcohol Test Given	Test Results:	Drug Test Given / Result		Charged: Yes No							
		<input type="checkbox"/>				<input type="radio"/> <input type="radio"/>								
Transported to:			Transported By:											

### 1 STRUCK BY UNIT NUMBER

**DEFINITION:** Number assigned to identify the motor vehicle that struck the non-motorist in the crash.

**RATIONALE:** Used for tracking; important information to have when multiple motor vehicles are involved in the crash.

Enter the unit number of the vehicle that actually hit the non-motorist in “Struck by Unit No.” field.

Code 04

**In or on building** – used when the person injured is inside of a building or on a building such as a loading dock outside of the building area.

Code 05

**Horse and buggy/Animal conveyance** – used when the person injured is riding on an animal or in an animal-powered vehicle.

Code 06

**Skater, personal conveyance, and wheelchairs** – used when the person injured was on a skate board, on roller skates, in a wheelchair whether motorized or not, or was on a personal conveyance such as a Segway.

Code 98

**Other non-motorist** (*explain in narrative*) – used when the injured party does not fit any of the above attributes.

Code 99

**Unknown** – used when information is unknown.

### 2 INJURY STATUS

Same options as for motorists - see page 49.

### 3 NON-MOTORIST TYPE

**DEFINITION:** A non-motorist is someone who is not in or a part of a motor vehicle such as a pedestrian, bicyclist, horse and buggy, etc.

**RATIONALE:** Need to know person type for classification purposes to evaluate specific countermeasures designed for specific people.

- Code 01**      **Pedestrian** – when the person is not an occupant of a vehicle and is standing, walking, running, jogging, hiking, sitting, or lying.
- Code 02**      **Pedalcyclist (bicycle, tricycle, unicycle, pedal car)** – used when it is a one, two, or three-wheeled, nonmotorized cycle or a vehicle that has four wheels but is propelled by pedal power.
- Code 03**      **Pedalcycle passenger** – used when the injured party was riding on a two or three-wheeled, nonmotorized cycle or a vehicle that has four wheels but is propelled by pedal power but was not the one using the pedals.







				Sex	Struck by Unit #	Injury Status	Non-Motorist Type	Location (prior to impact)	Action (prior to crash)	Condition	Safety Equipment	Contributing Circumstances	Source of Transport	Died at Scene/Enroute
N O	Name 1:	Phone Number:	Date of Birth:		1	2	3	4	5	6	7	8		
	Address:			Alcohol Test Given	Test Results:	Drug Test Given / Result		Charged: Yes No						
NM O T O	Transported to:			Transported By:										
	Name 2:			Phone Number:	Date of Birth:									
R I S T S	Address:			Alcohol Test Given	Test Results:	Drug Test Given / Result		Charged: Yes No						
	Transported to:			Transported By:										

### 5 ACTION (PRIOR TO CRASH)

**DEFINITION:** The action of the non-motorist immediately prior to the crash.

**RATIONALE:** The development of effective roadway design and operation, education, and enforcement measures to accommodate pedestrians and bicyclists and prevent crashes with motor vehicles is enhanced by the collection of the actions and circumstances prior to the crash.

- Code 01**      **Entering or crossing roadway** – used when the non-motorist had entered the roadway or was moving across the travel lanes with the goal of crossing the roadway.
- Code 02**      **Waiting to cross roadway** – used when the non-motorist is near the curb or the roadway edge waiting to cross a roadway anywhere along the roadway.
- Code 03**      **Going to/coming from school** – used when persons are age 5-18 or an adult supervising persons age 5-18 going to or from a school for any reason. Examples are going to a school dance, sports practice, or extracurricular activities.

- Code 04**      **Working in trafficway** – used when the non-motorist was in the roadway but not crossing it. Examples include conducting maintenance or as part of an official response to an incident, such as a firefighter moving between an emergency vehicle and a crash involved vehicle.
- Code 05**      **Approaching or leaving vehicle** – used when a person has already left the vehicle and is walking away from it or is approaching a vehicle
- Code 06**      **Entering/exiting vehicle** – used when a person is in the process of entering or has just gotten out of a vehicle.
- Code 07**      **Playing on or working on vehicle** – used when a person is playing on or working on a vehicle. This would be on the outside of the vehicle.
- Code 08**      **Disabled vehicle-related/pushing vehicle** – used when the pedestrian was outside of a disabled vehicle for any reason and includes pushing the vehicle.

NONMOTORIST	Name 1:	Phone Number:	Date of Birth:	Sex	1	2	3	4	5	6	7	8		
	Address:	Alcohol Test Given		Test Results:		Drug Test Given / Result		Charged: Yes		No				
RISKS	Transported to:		Transported By:											
	Name 2:	Phone Number:	Date of Birth:											
Address:		Alcohol Test Given		Test Results:		Drug Test Given / Result		Charged: Yes		No				
Transported to:		Transported By:												

**A. MOVEMENT**

- Code 10**      **Along roadway with traffic** – used when the non-motorist was not on a sidewalk and was moving in the same direction of traffic, either in the travel lane or adjacent to it (e.g., jogging or walking on shoulder or roadside).
  
- Code 11**      **Along roadway against traffic** – used when the non-motorist was not on a sidewalk and was moving in the opposite direction of traffic (facing oncoming vehicles), either in the travel lane or adjacent to it.
  
- Code 12**      **Along roadway (direction unknown)** – used when the non-motorist was not on a sidewalk and was moving in or adjacent to a travel lane but their direction with respect to the flow of traffic is unknown.
  
- Code 13**      **On shoulder/median** – used when the non-motorist was not in the roadway but in an area immediately adjacent to the roadway, such as a median or a shoulder, but not a sidewalk.
  
- Code 14**      **On sidewalk** – used when the non-motorist was moving (not standing) on the sidewalk.
  
- Code 98**      **Other** (*explain in narrative*) – used when none of the attributes reflect the action
  
- Code 99**      **Unknown**

**6 CONDITION**

**DEFINITION:** This element attempts to identify any physical impairment to this non-motorist which may have contributed to the cause of the crash.

**RATIONALE:** Important for evaluating the effect that fatigue, medications/alcohol/drugs, or other conditions have on the crash.

See **“Driver Condition”** on [page 24-25](#) for the code definitions, as the attributes used here are the same.

NON-MOTORIST	Name 1:	Phone Number:	Date of Birth:	Sex	Struck by Unit #	Injury Status	Non-Motorist Type	Location (prior to impact)	Action (prior to crash)	Condition	Safety Equipment	Contributing Circumstances	Source of Transport	Died at Scene/Enroute
	Address:	Alcohol Test Given		Test Results:		Drug Test Given / Result		Charged: Yes No						
RISKS	Transported to:			Transported By:										
	Name 2:	Phone Number:	Date of Birth:											
Address:		Alcohol Test Given		Test Results:		Drug Test Given / Result		Charged: Yes No						
Transported to:			Transported By:											

## 7 SAFETY EQUIPMENT

**DEFINITION:** This element indicates the safety equipment that was used by the non-motorist involved in the crash.

**RATIONALE:** Used to evaluate effectiveness of non-motorist safety equipment. It is important to calculate usage statistics for the development and evaluation of the effectiveness of educational countermeasures.

**Code 01**      **Not applicable** – used when no safety equipment applies to the situation.

**Code 02**      **None** – used when the non-motorist was not wearing or carrying any type of safety equipment.

**Code 03**      **Helmet** – used when the non-motorist was wearing a safety helmet. The non-motorist does not have to be riding a bicycle at the time of the crash to use this attribute. Use code 98 “Other” for a non-motorist wearing a motorcycle helmet.

**Code 04**      **Reflective clothing** – used when the non-motorist was wearing or carrying some type of reflective equipment. The emphasis is on the reflective property of the equipment and does not include devices that give off light under their own power such as flashlights. The equipment can be reflective tape affixed to regular clothing, special reflective clothing, a reflective device that is worn or a reflective device that is carried. It can be made by the nonmotorized and does not have to be specially designed as a safety device.

**Code 05**      **Lighting** – used when a non-motorist uses a light on his/her person or on a pedalcycle or personal conveyance for safety purposes, to include flashlights.

**Code 06**      **Protective pads** – used when the non-motorist was wearing padded, shaped attachments to protect specific areas of the body (elbows, knees, shins, etc.) from injury.

**Code 07**      **Multiple equipment** (*explain in narrative*) – used when the non-motorist is using several of the attributes listed above.

**Code 98**      **Other** (*explain in narrative*) – used when none of the above attributes fit the situation.

**Code 99**      **Unknown** – used when this information is not known.



NONMOTORIST	Name 1:	Phone Number:	Date of Birth:	Sex	Struck by Unit #	Injury Status	Non-Motorist Type	Location (prior to impact)	Action (prior to crash)	Condition	Safety Equipment	Contributing Circumstances	Source of Transport	Died at Scene/Enroute
					1	2	3	4	5	6	7	8		
MOTORIST	Address:		Alcohol Test Given	Test Results:	Drug Test Given / Result		Charged: Yes No							
	Transported to:			Transported By:										
MOTORIST	Name 2:	Phone Number:	Date of Birth:											
	Address:		Alcohol Test Given	Test Results:	Drug Test Given / Result		Charged: Yes No							
Transported to:			Transported By:											

### 8 CONTRIBUTING CIRCUMSTANCES

**DEFINITION:** The actions/circumstances of the non-motorist that may have contributed to the crash. This data element is based on the judgment of the law enforcement officer investigating the crash.

**RATIONALE:** The development of effective roadway design and operation, education, and enforcement measures to accommodate pedestrians and cyclists, and prevent crashes with motor vehicles is enhanced by the collection of the actions and circumstances at the time of the crash.

**Code 01**      **No improper action** – used when there is an indication that the non-motorist did nothing to contribute to the crash.

**Code 02**      **Not visible (dark clothing)** – used when the non-motorist was not visible to the motorist because of non-motorist wearing dark clothing or there was insufficient lighting to see them.

**Code 03**      **Improper crossing** – used when the non-motorist improperly crossed street/highway other than at a crosswalk, also called jaywalking.

**Code 04**      **Darting/Dashing** – used when a non-motorist either ran, rode, etc., into the roadway in front of a motorist whose view of the non-motorist was not obstructed or the non-motorist walked, ran, rode, etc., into the road and was struck by a motorist whose view of the non-motorist was blocked until an instant before impact.

**Code 05**      **Inattentive (talking, eating, texting)** – used when the non-motorist was talking, eating, or texting and not engaged in traffic safety.

**Code 06**      **Riding/walking on wrong side of road** – used when the non-motorist was walking or riding in a direction other than required by statute.

**Code 07**      **Failure to obey traffic signs, signals, or officer** – used when the non-motorist fails to obey any traffic sign, signal, or officer.

**Code 08**      **Failure to yield right of way** – used when there is a right of way violation by the non-motorist by failing to obey a traffic control device.

**Code 09**      **Failure to have lights on when required** – used when the non-motorist has a lightening devise but fails to use it when light is required for easy visibility.

**Code 10**      **Operating without required equipment** – used when the non-motorist does not have the required equipment needed (e.g., horse and buggy needs slow moving signage on back of buggy or other slow-moving vehicles that require a reflective flag attached).

**Code 11**      **Improper riding** – used when the non-motorist has more passengers than seats.

				Sex	Struck by Unit #	Injury Status	Non-Motorist Type	Location (prior to impact)	Action (prior to crash)	Condition	Safety Equipment	Contributing Circumstances	Source of Transport	Died at Scene/Enroute
NON-MOTORIST	Name 1:	Phone Number:	Date of Birth:		1	2	3	4	5	6	7	8		
	Address:		Alcohol Test Given	Test Results:	Drug Test Given / Result		Charged: Yes No							
RISKS	Transported to:			Transported By:										
	Name 2:	Phone Number:	Date of Birth:											
Address:		Alcohol Test Given	Test Results:	Drug Test Given / Result		Charged: Yes No								
Transported to:			Transported By:											

**Code 12**      **Improper turn/merge** – used when the non-motorist made an improper turn or improperly merged into traffic.

**Code 13**      **Improper passing** – used when the non-motorist made an improper pass.

**Code 14**      **Passing with insufficient distance or inadequate visibility** – used when the non-motorist passed without allowing enough distance around vehicle being passed or failed to have adequate visibility to make the pass.

**Code 15**      **Improper/Erratic lane changing** – used when the non-motorist is making improper or erratic lane changes.

**Code 16**      **Failure to remain in proper lane** – used when the non-motorist does not stay in proper lane but crosses over the lane and back.

**Code 17**      **Operating in a reckless, erratic, careless, negligent manner** – used when the non-motorist is operating a transport vehicle other than a motor vehicle in a reckless, erratic, careless, or negligent manner.

**Code 18**      **Improper exit/entry from trafficway** – used when the non-motorist uses an exit or entry way improperly from a trafficway.

**Code 19**      **In roadway improperly** – used when the non-motorist is standing, sitting, lying, working, or playing in the roadway.

**Code 20**      **Disabled vehicle-related** – used when the non-motorist is working on, pushing, or leaving/approaching a disabled vehicle.

**Code 21**      **Entering/exiting parked/standing vehicle** – used when the non-motorist is entering a vehicle but is not inside the vehicle or has just gotten out of the vehicle and is outside a vehicle that is parked, or the engine is running but the vehicle is not moving.

**Code 98**      **Other** (*explain in narrative*) – used when none of the above attributes describe the situation.

**Code 99**      **Unknown** – used when the information is not known.

N O N V E H I C L E D A M A G E	If Property other than vehicles damaged explain.	1 Object Damaged				Estimate of Damage
	Owner's Last Name	3	First Name	3	Middle Name	3
	Address	4	City	4	State	4
			ZIP Code	4	Was owner or tenant notified?	5
					1 = Yes 2 = No 9 = Unknown	
	If Property other than vehicles damaged explain.	Object Damaged				Estimate of Damage
	Owner's Last Name		First Name		Middle Name	Phone Number
	Address		City		State	ZIP Code
						Was owner or tenant notified? 1 = Yes 2 = No 9 = Unknown <input type="checkbox"/>

## PROPERTY DAMAGE SECTION

The “**Property damage**” section is to be completed only if there is property damage to objects other than motor vehicles, attachments to vehicles, and land. Property damage includes injury or death of domestic animals, but not injury or death of nondomestic animals such as deer. This does not include personal items in the vehicle. If there was an attachment to a vehicle, this amount should be included with the estimated cost of repair under the “**Owner**” section.

### 1 PROPERTY DAMAGE

“If property other than motor vehicles damaged explain,” enter the name of the item damaged in the “**Object Damaged**” field.

### 2 ESTIMATE OF DAMAGE

Enter the estimated cost to the nearest dollar in the “**Estimate of Damage**” field.

### 3 OWNER’S NAME

Enter the owner’s name in the “**Owner’s Last Name**,” “**First Name**,” and “**Middle Name**” fields. Also enter the owner’s phone number in the “**Phone Number**” field.

### 4 ADDRESS

Enter the street address of the owner or the tenant in “**Address**,” “**City**,” “**State**,” and “**ZIP Code**” fields.

**Note:** When only one owner has property damage to several objects, the required information may be entered on one report. When more than one owner has property damage, each owner’s damage information must be entered. The Supplemental Investigating Officer’s Report of Motor Vehicle Crash form may be used for the additional information.

### 5 OWNER NOTIFIED

Place the appropriate code in the “**Was owner or tenant notified?**” field to show if the owner or tenant of the damaged property was notified.

- Code 1                      Yes
- Code 2                      No
- Code 9                      Unknown

W I T N E S S	Last Name <b>1</b>	First Name <b>1</b>	<b>2</b> Address	<b>2</b> City	<b>2</b> State	<b>2</b> ZIP Code	<b>3</b> Phone Number:
	Last Name	First Name	Address	City	State	ZIP Code	Phone Number:
	Last Name	First Name	Address	City	State	ZIP Code	Phone Number:
	Last Name	First Name	Address	City	State	ZIP Code	Phone Number:

## WITNESS

---

The witness block is used to record information concerning witnesses who saw the crash occur.

### 1 NAME

Enter the witness' full name in the “**Last Name**” and “**First Name**” fields.

### 2 ADDRESS

Enter the witness' complete address in the “**Address**,” “**City**,” “**State**,” and “**ZIP Code**” fields.

### 3 PHONE NUMBER

Enter the witness' complete phone number in the “**Phone Number**” field.

Is This a Secondary Crash?: Y <input type="radio"/> N <input type="radio"/> <b>1</b>	Type of Primary Incident: <b>2</b>	Roadway Clearance Date: <b>3</b>	Incident Clearance Date: <b>6</b>
Signature of Officer:	Badge Number:	Time Officer Notified of Accident: Hrs. <b>4</b>	Incident Clearance Time: <b>7</b>
Name of Agency:	Date of Report:	Time Officer Arrived at Scene: Hrs. <b>5</b>	Total Incident Clearance Time: <b>8</b>
		Total Roadway Clearance Time: <b>5</b>	

## SECONDARY CRASH

The “**Secondary Crash**” block is used to enter information concerning Secondary Crashes such as type and clearance times.

A “**Secondary Crash**” is defined as: A motor vehicle traffic crash within a traffic incident scene or within a traffic queue in either direction resulting from a prior traffic incident.

The original incident does not have to be a collision. It could be a disabled motorist, vehicles on the side of the road, traffic stop, or any other unusual circumstance related to traffic backup or change in traffic flow as long as it played a role in distracting the driver or the causation in the collision. If the queue is normal, everyday occurrence without an original unplanned incident then a crash is not secondary.

### 1 IS THIS A SECONDARY CRASH?

If this is a “**Secondary Crash**” mark “Y”. If not, mark “N”.

### 2 TYPE OF PRIMARY INCIDENT

**DEFINITION:** This element identifies the type of Primary Incident that this crash is connected to.

**RATIONALE:** The information this data element provides is used to classify the primary incident as being a motor vehicle traffic crash or not, based on the location where it occurred. Collecting this data on the crash report allows research and resources to be targeted and countermeasures to be evaluated based on the characteristics of the crash.

- Code 1**      **Vehicle crash** – This crash is subsequent to a previous crash.
- Code 2**      **Traffic Stop** – This crash is possibly due to slow traffic near a traffic stop.
- Code 3**      **Roadway debris** - This crash is in traffic that has slowed due to debris in the roadway that is not large enough to block travel but could cause damage or a loss of control. Items such as dislodged cargo, parts from a vehicle, tire tread, ladders, or animal carcasses.
- Code 4**      **Motorist assist** – This crash is in traffic that has slowed down near a motorist assist.
- Code 5**      **Other** – *Explain in narrative*

### 3 ROADWAY CLEARANCE DATE

The date of first confirmation that all lanes are available for traffic flow.

### 4 ROADWAY CLEARANCE TIME

The time of first confirmation that all lanes are available for traffic flow.

### 5 TOTAL ROADWAY CLEARANCE TIME

This is the total time from when the first officer is notified of the crash until the Roadway Clearance Time.

### 6 INCIDENT CLEARANCE DATE

This is the date when the last responder has left the scene.

### 7 INCIDENT CLEARANCE TIME

This is the time that the last responder has left the scene.

### 8 TOTAL CLEARANCE TIME

This is the total time from when the first officer is notified of the crash until the Incident Clearance Time.



Signature of Officer: <b>1</b>	Badge Number: <b>2</b>	Time Officer Notified of Accident: <b>3</b> Hrs.		
Name of Agency: <b>4</b>	Date of Report: <b>5</b>	Time Officer Arrived at Scene: <b>6</b> Hrs.		
Report Reviewed By: <b>7</b>	Date of Review: <b>8</b>	Investigation made at scene? Y <input type="radio"/> N <input type="radio"/> <b>9</b>	T.I. #: <b>10</b>	Other Technical Investigating Agency: <b>11</b>

## OFFICER SECTION

The **“Officer block”** is used to enter information concerning the officer completing the report and other data such as when the officer arrived.

### 1 SIGNATURE OFFICER

Enter the officer’s title and name in the **“Signature of Officer”** field (e.g., Patrolman John Doe, Trooper Jane Doe, or Deputy Joe Schmoe).

### 2 BADGE NUMBER

Enter the officer’s badge number in the **“Badge Number”** field. Troopers must enter their badge number and the post to which they are assigned (e.g., 58-2).

### 3 TIME OFFICER NOTIFIED OF ACCIDENT

Enter the time (using 24-hour time) the officer was notified of the crash in the **“Time Officer Notified of Accident”** field.

### 4 NAME OF AGENCY

Enter the name of the officer’s department in the **“Name of Agency”** field (e.g., Ankeny Police Department).

### 5 DATE OF REPORT

Enter the date the report was written in the **“Date of Report”** using the MM/DD/YYYY format.

### 6 TIME OFFICER ARRIVED AT SCENE

Enter the time (using 24-hour time) the officer arrived at the crash in the **“Time Officer Arrived at Scene”** field.

### 7 REPORT REVIEWED BY

Enter the name of the person that reviewed the report in the **“Report Reviewed By”** field.

### 8 DATE OF REVIEW

Enter the date the report was reviewed in the **“Date of Review”** field using the MM/DD/YYYY format

### 9 INVESTIGATION MADE AT SCENE?

Mark the appropriate circle, Y for Yes or N for No, to indicate if an investigation was made at the scene in the **“Investigation made at scene?”** field.

### 10 T.I. CASE #

If another agency is doing a technical investigation on this crash, enter that agency’s case number for the crash in the **“T.I. No.”** field.

### 11 OTHER TECHNICAL INVESTIGATING AGENCY

If another agency is doing a technical investigation on this crash, enter the name and number of the agency in the **“Other Technical Investigating Agency”** field.

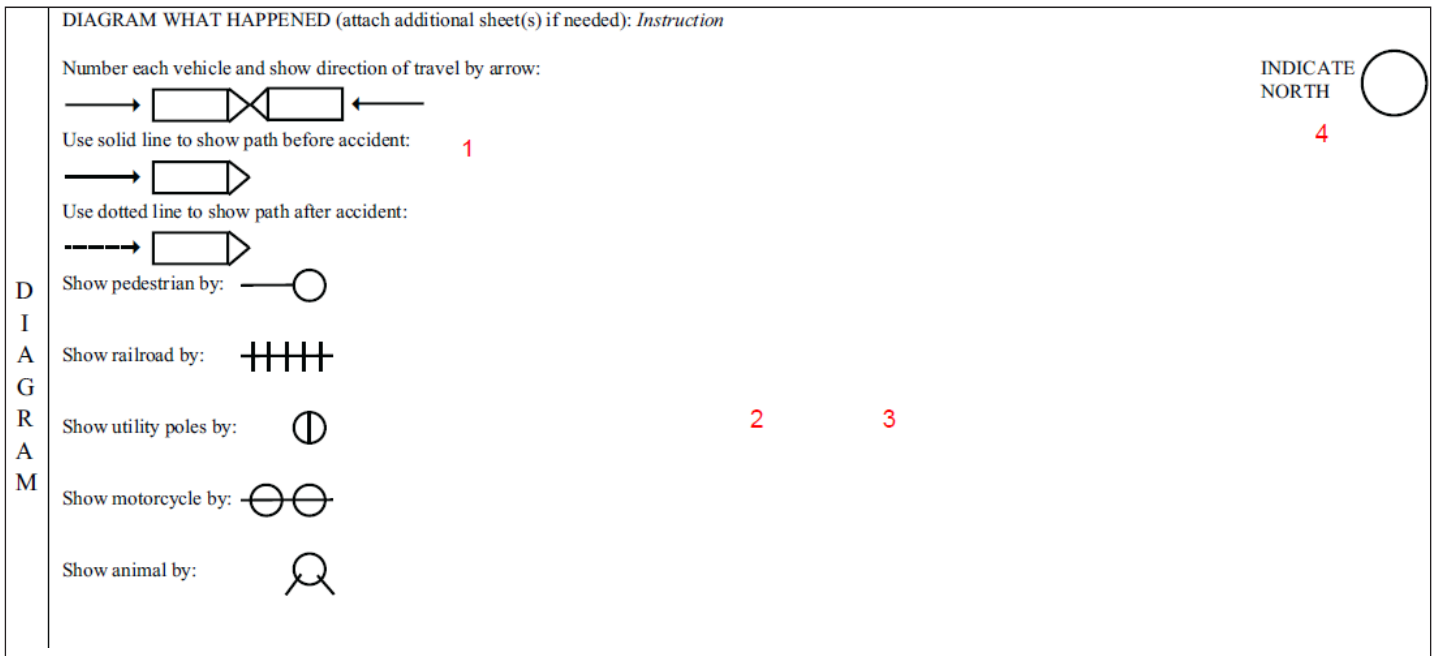

## DIAGRAM SECTION

The diagram space is used to draw a picture that visually details how the crash occurred. A diagram is required. Just because the vehicles have moved does not mean you can not create a diagram based on your investigation.

### 1 OUTLINE ROADWAY

Draw an outline of the roadway or draw the roadway in any manner necessary to adequately depict the crash scene in the “Diagram What Happened” field. The symbols to use are show on the diagram above.

### 2 LABEL ROAD NAMES

Enter the number(s) or name(s) of the road(s), street(s), or highway(s) near where you draw the diagram.

### 3 NUMBER EACH VEHICLE

Number each vehicle according to the numbers assigned on page 1 of the report form (“unit 1,” “unit 2,” “unit 3,” and so on) and show the direction of travel by using arrows. Use a solid line to show a path before the crash and a dotted line after the crash.

### 4 INDICATE NORTH

Show north by an arrow in the circle, which is located in the upper right corner labeled “Indicate North.” Diagram the crash with north at the top of the report whenever possible.

## NARRATIVE SECTION

The “**Narrative**” section may be used to provide additional information whenever other portions of the report lack sufficient space to provide adequate explanations. Use the “**Describe what happened**” field and refer to each vehicle by number (“unit 1,” “unit 2,” “unit 3,” and such).

N A R R A T I V E	Describe what happened (attach additional sheet(s) if needed)

Describe what happened completely, use additional forms if necessary. The description must give the main events of the crash; clearly state the action of vehicles and pedestrians involved. Information needed to clarify information entered in other fields on the form may also be entered in the “**Narrative**” section of the form.

Remember, the Investigative Officer’s Crash Report is a traffic report, not the place to include information about civil disputes or other details that do not pertain to the circumstances immediately surrounding the crash.

- **Do** include details that directly contributed to the crash.
- **Do not** include irrelevant details such as a driver’s destination; “Driver 1 was going to the grocery store to buy milk when, or where you were when you received the call, or what car you were in ...”
- **Do** include results of an investigation but **not** necessarily the details of the process.
- **Do not** include any Personal Identifiable Information (PII) such as, names, insurance policy numbers, names of insurance agents, DL numbers, plate numbers, VIN, DOB, phone numbers, or addresses of anyone.
- **Do not** list “Property Damage” or “Witnesses” in the narrative. There are sections in the report for these items.

## INTERSECTION DEFINITIONS

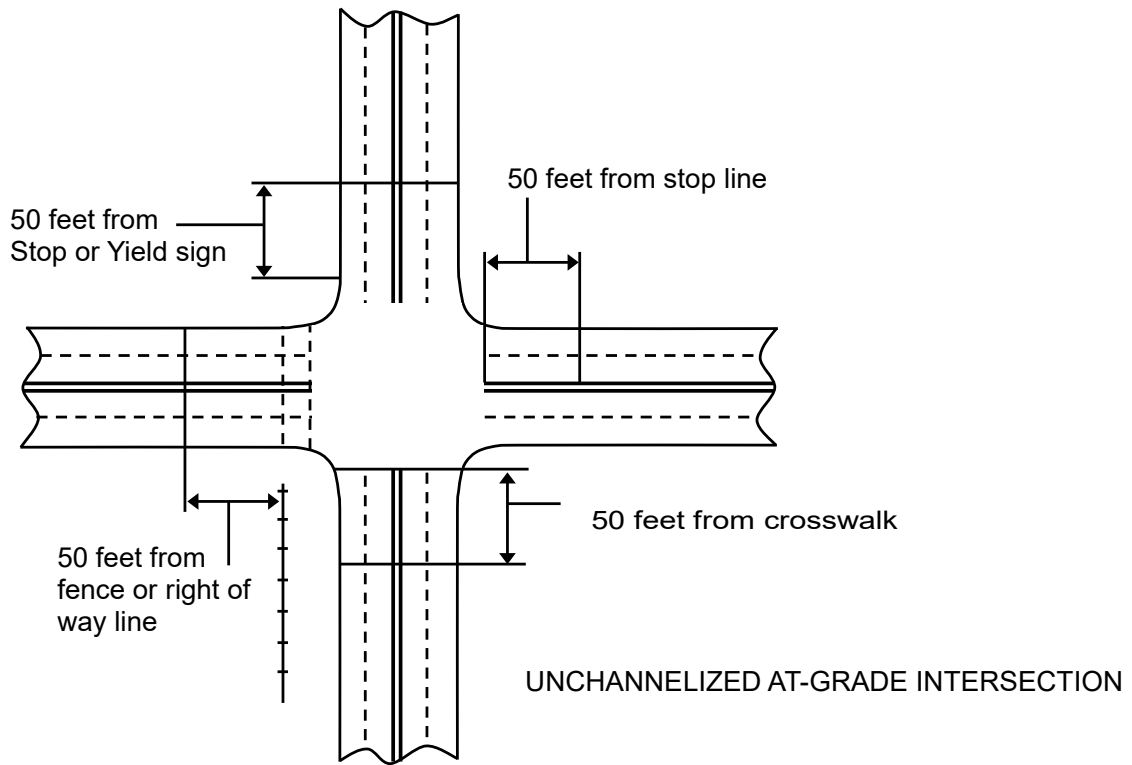

UNCHANNELIZED AT-GRADE INTERSECTION — area within a boundary 50 feet beyond the crosswalk, stop line markings, Stop or Yield signs, or in the absence of these features, the edge of the roadway.

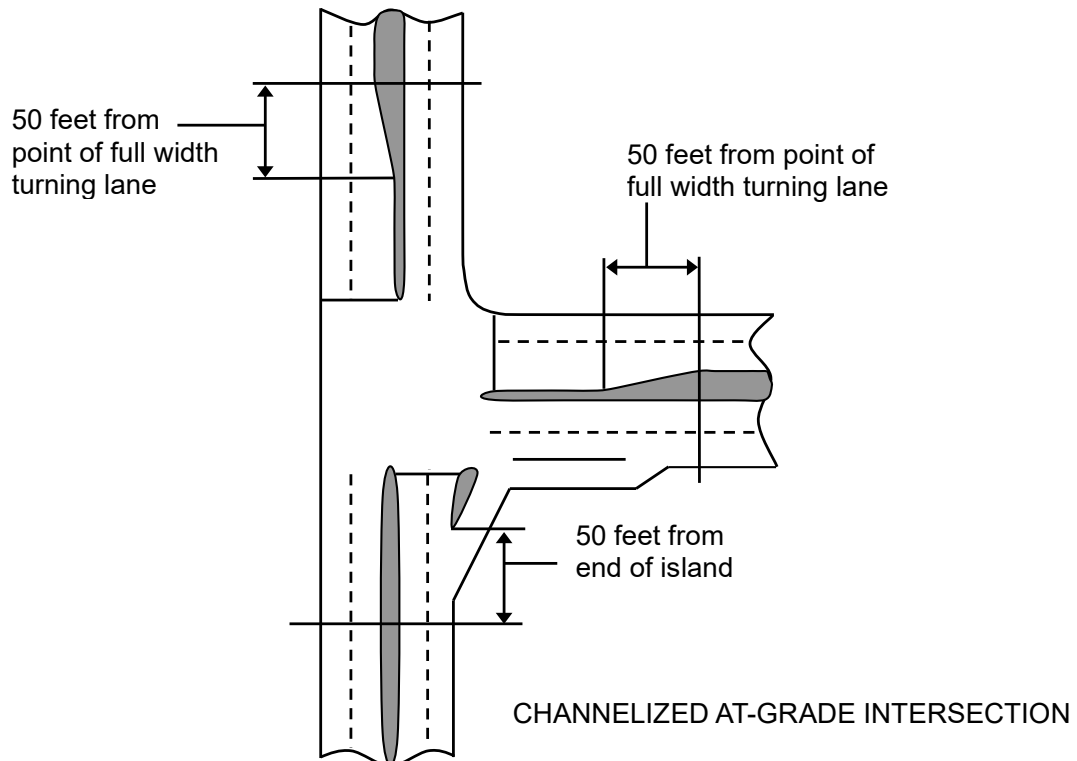

CHANNELIZED AT-GRADE INTERSECTION — area within a boundary 50 feet beyond the island or point where full width turning lane begins.

## STATE AND U.S. TERRITORY ABBREVIATIONS

---

Alabama	AL	Montana	MT
Alaska	AK	Nebraska	NE
American Samoa	AS	Nevada	NV
Arizona	AZ	New Hampshire	NH
Arkansas	AR	New Jersey	NJ
California	CA	New Mexico	NM
Colorado	CO	New York	NY
Connecticut	CT	North Carolina	NC
Delaware	DE	North Dakota	ND
District of Columbia	DC	North Marianas Islands	MP
Florida	FL	Ohio	OH
Georgia	GA	Oklahoma	OK
Guam	GU	Oregon	OR
Hawaii	HI	Pennsylvania	PA
Idaho	ID	Puerto Rico	PR
Illinois	IL	Rhode Island	RI
Indiana	IN	South Carolina	SC
Iowa	IA	South Dakota	SD
Kansas	KS	Tennessee	TN
Kentucky	KY	Texas	TX
Louisiana	LA	Utah	UT
Maine	ME	Vermont	VT
Maryland	MD	Virginia	VA
Massachusetts	MA	Virgin Islands	VI
Michigan	MI	Washington	WA
Minnesota	MN	West Virginia	WV
Mississippi	MS	Wisconsin	WI
Missouri	MO	Wyoming	WY

## 24-HOUR TIME

---

The method to calculate 24-hour time from the clock time is given below.

1. If the clock time is between midnight and 1 a.m., 24-hour time equals 00 + clock minutes (e.g., 12:45 a.m. is 0045).
2. If clock time is between 1 a.m. and 1 p.m., 24-hour time equals clock time, using four digits (e.g., 3:45 a.m. is 0345).
3. If clock time is from 1 p.m. to midnight, 24-hour time equals clock time + 12 hours (e.g., 2:45 p.m. is 1445).



## IOWA COUNTIES AND THEIR NUMBERS

1	Adair	34	Floyd	67	Monona
2	Adams	35	Franklin	68	Monroe
3	Allamakee	36	Fremont	69	Montgomery
4	Appanoose	37	Greene	70	Muscatine
5	Audubon	38	Grundy	71	O'Brien
6	Benton	39	Guthrie	72	Osceola
7	Black Hawk	40	Hamilton	73	Page
8	Boone	41	Hancock	74	Palo Alto
9	Bremer	42	Hardin	75	Plymouth
10	Buchanan	43	Harrison	76	Pocahontas
11	Buena Vista	44	Henry	77	Polk
12	Butler	45	Howard	78	Pottawattamie
13	Calhoun	46	Humboldt	79	Poweshiek
14	Carroll	47	Ida	80	Ringgold
15	Cass	48	Iowa	81	Sac
16	Cedar	49	Jackson	82	Scott
17	Cerro Gordo	50	Jasper	83	Shelby
18	Cherokee	51	Jefferson	84	Sioux
19	Chickasaw	52	Johnson	85	Story
20	Clarke	53	Jones	86	Tama
21	Clay	54	Keokuk	87	Taylor
22	Clayton	55	Kossuth	88	Union
23	Clinton	56	Lee	89	Van Buren
24	Crawford	57	Linn	90	Wapello
25	Dallas	58	Louisa	91	Warren
26	Davis	59	Lucas	92	Washington
27	Decatur	60	Lyon	93	Wayne
28	Delaware	61	Madison	94	Webster
29	Des Moines	62	Mahaska	95	Winnebago
30	Dickinson	63	Marion	96	Winneshiek
31	Dubuque	64	Marshall	97	Woodbury
32	Emmet	65	Mills	98	Worth
33	Fayette	66	Mitchell	99	Wright

# CODE SHEET

The following shows an example of the code sheet Iowa DOT Form 433014. This form is also available for download on the IowaDOT's website: [www.iowadot.gov/mvd/ods/accidents.htm](http://www.iowadot.gov/mvd/ods/accidents.htm).

Page 1 of 4



## INVESTIGATING OFFICER'S REPORT OF MOTOR VEHICLE ACCIDENT CODE SHEET

Vehicle Characteristics			
<p><b>Initial Travel Direction (prior to coded Vehicle Action)</b></p> <p>1 - North 2 - East 3 - South 4 - West 99 - Unknown</p>	<p><b>Vehicle Configuration</b></p> <p>1 - Passenger car 2 - Four-tire truck (pick-up) 3 - Sport utility vehicle 4 - Passenger van (seats &lt;9) 5 - Passenger van (seats 9-15) 6 - Cargo/panel van 7 - Single-unit truck (2-axle, 6-tire) 8 - Single-unit truck (&gt;=3 axles) 9 - Other light truck (&lt;=10,000 lbs) 10 - Vehicle &lt;=10,000lbs, placarded for hazardous materials 11 - Truck/trailer 12 - Truck tractor (bobtail) 13 - Tractor/semi-trailer 14 - Tractor/doubles 15 - Tractor/triples 16 - Other heavy truck (&gt;10,000 lbs) (cannot classify) 17 - Motorcycle 18 - 3-wheeled, enclosed 19 - 3-wheeled, unenclosed 20 - Moped</p> <p>21 - Motor home/recreational vehicle 22 - School bus (seats &gt;15) 23 - Small school bus (seats 9-15) 24 - Other bus (seats &gt;15) 25 - Other small bus (seats 9-15) 26 - Farm tractor 27 - Farm equipment (explain in narrative) 28 - All-terrain vehicle (ATV) 29 - Snowmobile 30 - Golf cart 31 - Street legal, low-speed vehicle 32 - Limousine/taxi (seats 8 or less) 33 - Limousine/taxi (seats 9-15) 34 - Limousine/taxi (seats &gt;15) 35 - Maintenance/construction vehicle 36 - Train 98 - Other (explain in narrative) 99 - Unknown</p>	<p><b>Cargo Body Type</b></p> <p>1 - Not applicable 2 - Van/enclosed box 3 - Dump (grain/gravel) 4 - Cargo tank 5 - Flatbed 6 - Concrete mixer 7 - Auto transporter 8 - Garbage/refuse 9 - Hopper (grain, chips, gravel) 10 - Pole trailer 11 - Log trailer 12 - Intermodal container chassis 13 - Small utility trailer (one-axle) 14 - Large utility trailer (2+axles) 15 - Boat 16 - Camper 17 - Large mobile home 18 - Oversize load 19 - Towed vehicle 20 - Bus 98 - Other (explain in narrative) 99 - Unknown</p>	
<p><b>Vehicle Action</b></p> <p>1 - Movement essentially straight 2 - Turning Left 3 - Turning right 4 - Making U-turn 5 - Overtaking/passing 6 - Changing lanes 7 - Entering traffic lane (merging) 8 - Leaving traffic lane 9 - Backing 10 - Slowing/stopping (decelerating) 11 - Stopped in traffic 12 - Legally parked 13 - Illegally parked/unattended 14 - Negotiating a curve 15 - Starting in road 16 - Accelerating in road 17 - Leaving a parked position 18 - Entering a parked position 98 - Other (explain in narrative) 99 - Unknown</p>	<p><b>Vehicle Defect</b></p> <p>1 - None 2 - Brake system 3 - Steering 4 - Blowout 5 - Other tire defect (explain in narrative) 6 - Wheels 7 - Windows/windshield 8 - Wipers 9 - Mirrors 10 - Trailer hitch/truck coupling, safety chain</p> <p>11 - Headlights 12 - Tail lights 13 - Turn signal 14 - Body/doors 15 - Power train 16 - Suspension 17 - Exhaust 18 - Safety systems 98 - Other (explain in narrative) 99 - Unknown</p>		
<p><b>Point of Initial Impact Most Damaged Area</b></p> <p>14 - Undercarriage 15 - Non-collision/no damage 16 - Cargo loss 98 - Other (explain in narrative) 99 - Unknown</p>	<p><b>Towed Field</b></p> <p>1 - Driven away 2 - Disabled - privately arranged 3 - Disabled - officer arranged 4 - Not disabled - privately arranged 5 - Not disabled - officer arranged 6 - Abandoned/left at scene</p>	<p><b>Hazardous Materials (cargo only)</b></p> <p><b>Involvement</b></p> <p>1 - Yes 2 - No 3 - Not applicable 99 - Unknown</p> <p><b>Placard</b></p> <p>1 - Yes 2 - No 3 - Not applicable 99 - Unknown</p> <p><b>Released</b></p> <p>1 - Yes 2 - No 3 - Not applicable 99 - Unknown</p>	
	<p><b>Extent of Damage</b></p> <p>1 - None 2 - Minor Damage 3 - Functional damage 4 - Disabling damage 5 - Severe, vehicle totalled 9 - Unknown</p>	<p><b>Commercial Motor Vehicle</b></p> <p><b>Converter Dolly</b></p> <p>1 - Yes 2 - No dolly used 3 - No information/label or unreadable 9 - Unknown</p> <p><b>Gross Vehicle Weight Rating (GVWR)</b></p> <p>1 - 10,000 lbs or less 2 - 10,001 lbs -26,000 lbs 3 - 26,001 lbs or more</p>	
	<p><b>Special Vehicles</b></p> <p><b>Special Function of Vehicle</b></p> <p>1 - No special function 2 - Police 3 - Fire 4 - Ambulance 5 - Incident response vehicle 6 - Non-transport emergency service vehicle 7 - Military 8 - Snow plow 9 - Taxi 10 - School 98 - Other (explain in narrative) 99 - Unknown</p>		<p><b>Emergency Status</b></p> <p>1 - Not applicable 2 - Yes, warning equipment used 3 - Yes, warning equipment not used 4 - No, non-emergency, non-transport 5 - No, non-emergency, transport 99 - Unknown</p>
	<p><b>Bus Use</b></p> <p>1 - School (public or private) 2 - Transit/commuter 3 - Intercity 4 - Charter/tour 5 - Shuttle 6 - Modified for personal/private use 7 - Church 98 - Other (explain in narrative) 99 - Unknown</p>		



INVESTIGATING OFFICER'S REPORT OF MOTOR VEHICLE ACCIDENT  
CODE SHEET

Driver Characteristics																																																					
<b>Contributing Circumstances, Driver (up to two)</b> 1 - Ran traffic signal 2 - Ran Stop sign 3 - Exceeded authorized speed 4 - Driving less than the posted speed limit 5 - Driving too fast for conditions 6 - Lost control 7 - Followed too close 8 - Operating vehicle in a reckless, erratic careless, negligent manner 9 - Improper or erratic lane changing 10 - Aggressive driving/road rage 11 - Made improper turn 12 - Failed to yield to emergency vehicle 13 - Traveling wrong way/on wrong side 14 - Traveling on prohibited traffic way 15 - Over-correcting/over-steering 16 - Failed to keep in proper lane 17 - Failure to signal intentions 18 - Swerved to avoid: vehicle, object non-motorist, or animal in roadway 19 - Starting or backing improperly 20 - Failure to dim lights/have lights on 21 - Vehicle stopped on railroad tracks 22 - Vehicle drove around grade crossing gates  <b>Passing</b> 30 - On wrong side 31 - Where prohibited by signs/markings 32 - With insufficient distance/inadequate visibility 33 - Through/around barrier 96 - Other passing (explain in narrative)		<b>Driver Re-Examination Needed:</b> 1 - Yes (explain in narrative) 2 - No  <b>Driver Distraction:</b> 1 - Not applicable/no driver 2 - Not distracted  <b>Electronic devices:</b> 3 - Manual operation of an electronic communication device (texting, typing, dialing) 4 - Talking on hand-held device 5 - Talking on hands free device 6 - Adjusting devices (radio, climate) 96 - Other activity with electronic device (explain in narrative)  <b>Other distraction inside vehicle:</b> 10 - Passenger 11 - Unrestrained animal 12 - Eating or drinking related 13 - Smoking related 14 - Reaching for object(s)/fallen object(s) 15 - Inattentive/lost in thought 16 - Looked but did not see 97 - Other distraction inside vehicle (explain in narrative)  98 - Distraction outside vehicle (explain in narrative) 99 - Unknown																																																			
<b>Failed to yield right-of-way (FTYROW):</b> 40 - From Stop sign 41 - From Yield sign 42 - Making left turn 43 - Making right turn on red signal 44 - From driveway 45 - From parked position 46 - To non-motorist 47 - At uncontrolled intersection 97 - Other FTYROW (explain in narrative)  <b>Other (explain in narrative):</b> 50 - Vision obstructed 51 - Operating without required equipment 52 - Failure to obey displayed vehicle warnings or instructions 53 - Disregarded signs/road markings 54 - Illegal off-road driving 55 - Towing improperly 56 - Getting off/out of vehicle 57 - Overloading/improper loading with passengers/cargo  58 - Operator inexperience  88 - No improper action  98 - Other (explain in narrative) 99 - Unknown		<b>Driver Condition</b> 1 - Apparently normal 2 - Emotional (e.g., depressed, angry) 3 - Asleep/fatigued 4 - Illness/fainted 5 - Medical condition (seizure, reaction) 6 - Under the influence of alcohol 7 - Under the influence of drugs/meds 8 - Physical impairment 9 - Walks with a cane/crutches 10 - Paraplegic/wheelchair restricted 11 - Impaired due to previous injury 12 - Hearing impaired/deaf 13 - Visually impaired 98 - Other (explain in narrative) 99 - Unknown																																																			
<b>Vision Obscured</b> 1 - Not obscured 2 - Trees/crops 3 - Embankment 4 - Hillcrest 5 - Building(s) 6 - Sign/billboard 7 - Parked vehicle(s) 8 - Moving vehicle(s) 9 - Person/object in or on vehicle 10 - Blinded by sun or headlights 11 - Broken/dirty windshield 12 - Frosted windows/windshield 13 - External mirrors 14 - Blowing snow 15 - Fog/smoke/dust 16 - Splash/spray of passing vehicle 17 - Inadequate vehicle lighting 18 - Exterior angle/blind spot on vehicle 98 - Other (explain in narrative) 99 - Unknown		<b>Accident Environment</b> <table border="1"> <thead> <tr> <th>Location of First Harmful Event</th> <th>Manner of Crash/Collision</th> </tr> </thead> <tbody> <tr> <td>1 - On roadway</td> <td>1 - Non-collision (single vehicle)</td> </tr> <tr> <td>2 - Shoulder</td> <td>2 - Head-on (front to front)</td> </tr> <tr> <td>3 - Median</td> <td>3 - Rear end (front to rear)</td> </tr> <tr> <td>4 - Roadside</td> <td>4 - Angle, oncoming left turn</td> </tr> <tr> <td>5 - Gore</td> <td>5 - Broadside (front to side)</td> </tr> <tr> <td>6 - Outside trafficway</td> <td>6 - Sideswipe, same direction</td> </tr> <tr> <td>7 - In parking lane/zone</td> <td>7 - Sideswipe, opposite direction</td> </tr> <tr> <td>8 - Continuous left turn lane</td> <td>8 - Rear to rear</td> </tr> <tr> <td>9 - Separator</td> <td>9 - Rear to side</td> </tr> <tr> <td>98 - Other (explain in narrative)</td> <td>98 - Other (explain in narrative)</td> </tr> <tr> <td>99 - Unknown</td> <td>99 - Unknown</td> </tr> </tbody> </table> <table border="1"> <thead> <tr> <th>Weather Conditions (up to two)</th> <th>Surface Conditions</th> </tr> </thead> <tbody> <tr> <td>1 - Clear</td> <td>1 - Dry</td> </tr> <tr> <td>2 - Cloudy</td> <td>2 - Wet</td> </tr> <tr> <td>3 - Fog, smoke, smog</td> <td>3 - Ice/Frost</td> </tr> <tr> <td>4 - Freezing rain/drizzle</td> <td>4 - Snow</td> </tr> <tr> <td>5 - Rain</td> <td>5 - Slush</td> </tr> <tr> <td>6 - Sleet, hail</td> <td>6 - Mud, dirt</td> </tr> <tr> <td>7 - Snow</td> <td>7 - Water (standing or moving)</td> </tr> <tr> <td>8 - Blowing snow</td> <td>8 - Sand</td> </tr> <tr> <td>9 - Severe winds</td> <td>9 - Oil</td> </tr> <tr> <td>10 - Blowing sand, soil, dirt</td> <td>10 - Gravel</td> </tr> <tr> <td>98 - Other (explain in narrative)</td> <td>98 - Other (explain in narrative)</td> </tr> <tr> <td>99 - Unknown</td> <td>99 - Unknown</td> </tr> </tbody> </table>		Location of First Harmful Event	Manner of Crash/Collision	1 - On roadway	1 - Non-collision (single vehicle)	2 - Shoulder	2 - Head-on (front to front)	3 - Median	3 - Rear end (front to rear)	4 - Roadside	4 - Angle, oncoming left turn	5 - Gore	5 - Broadside (front to side)	6 - Outside trafficway	6 - Sideswipe, same direction	7 - In parking lane/zone	7 - Sideswipe, opposite direction	8 - Continuous left turn lane	8 - Rear to rear	9 - Separator	9 - Rear to side	98 - Other (explain in narrative)	98 - Other (explain in narrative)	99 - Unknown	99 - Unknown	Weather Conditions (up to two)	Surface Conditions	1 - Clear	1 - Dry	2 - Cloudy	2 - Wet	3 - Fog, smoke, smog	3 - Ice/Frost	4 - Freezing rain/drizzle	4 - Snow	5 - Rain	5 - Slush	6 - Sleet, hail	6 - Mud, dirt	7 - Snow	7 - Water (standing or moving)	8 - Blowing snow	8 - Sand	9 - Severe winds	9 - Oil	10 - Blowing sand, soil, dirt	10 - Gravel	98 - Other (explain in narrative)	98 - Other (explain in narrative)	99 - Unknown	99 - Unknown
Location of First Harmful Event	Manner of Crash/Collision																																																				
1 - On roadway	1 - Non-collision (single vehicle)																																																				
2 - Shoulder	2 - Head-on (front to front)																																																				
3 - Median	3 - Rear end (front to rear)																																																				
4 - Roadside	4 - Angle, oncoming left turn																																																				
5 - Gore	5 - Broadside (front to side)																																																				
6 - Outside trafficway	6 - Sideswipe, same direction																																																				
7 - In parking lane/zone	7 - Sideswipe, opposite direction																																																				
8 - Continuous left turn lane	8 - Rear to rear																																																				
9 - Separator	9 - Rear to side																																																				
98 - Other (explain in narrative)	98 - Other (explain in narrative)																																																				
99 - Unknown	99 - Unknown																																																				
Weather Conditions (up to two)	Surface Conditions																																																				
1 - Clear	1 - Dry																																																				
2 - Cloudy	2 - Wet																																																				
3 - Fog, smoke, smog	3 - Ice/Frost																																																				
4 - Freezing rain/drizzle	4 - Snow																																																				
5 - Rain	5 - Slush																																																				
6 - Sleet, hail	6 - Mud, dirt																																																				
7 - Snow	7 - Water (standing or moving)																																																				
8 - Blowing snow	8 - Sand																																																				
9 - Severe winds	9 - Oil																																																				
10 - Blowing sand, soil, dirt	10 - Gravel																																																				
98 - Other (explain in narrative)	98 - Other (explain in narrative)																																																				
99 - Unknown	99 - Unknown																																																				
<b>Alcohol/Drug Testing</b> <table border="1"> <thead> <tr> <th>Alcohol Test Given</th> <th>Drug Test Given</th> <th colspan="2">Drug Test Result</th> </tr> </thead> <tbody> <tr> <td>1 - None</td> <td>1 - None</td> <td>1 - Negative</td> <td>6 - Inhalants</td> </tr> <tr> <td>2 - Blood</td> <td>2 - Blood</td> <td>2 - Cannabis</td> <td>7 - Narcotic</td> </tr> <tr> <td>3 - Urine</td> <td>3 - Urine</td> <td>3 - Central Nervous Sys. depressants</td> <td>8 - Disociative</td> </tr> <tr> <td>4 - Breath</td> <td>4 - Breath</td> <td>4 - Central Nervous Sys, stimulants</td> <td>9 - Prescription Drug</td> </tr> <tr> <td>5 - Vitreous</td> <td>5 - Vitreous</td> <td>5 - Hallucinogens</td> <td>98 - Other (explain in narrative)</td> </tr> <tr> <td>9 - Refused</td> <td>9 - Refused</td> <td></td> <td></td> </tr> </tbody> </table>		Alcohol Test Given	Drug Test Given	Drug Test Result		1 - None	1 - None	1 - Negative	6 - Inhalants	2 - Blood	2 - Blood	2 - Cannabis	7 - Narcotic	3 - Urine	3 - Urine	3 - Central Nervous Sys. depressants	8 - Disociative	4 - Breath	4 - Breath	4 - Central Nervous Sys, stimulants	9 - Prescription Drug	5 - Vitreous	5 - Vitreous	5 - Hallucinogens	98 - Other (explain in narrative)	9 - Refused	9 - Refused			<b>Light Conditions</b> 1 - Daylight 2 - Dusk 3 - Dawn 4 - Dark, roadway lighted 5 - Dark, roadway not lighted 6 - Dark, unknown roadway lighting 9 - Unknown																							
Alcohol Test Given	Drug Test Given	Drug Test Result																																																			
1 - None	1 - None	1 - Negative	6 - Inhalants																																																		
2 - Blood	2 - Blood	2 - Cannabis	7 - Narcotic																																																		
3 - Urine	3 - Urine	3 - Central Nervous Sys. depressants	8 - Disociative																																																		
4 - Breath	4 - Breath	4 - Central Nervous Sys, stimulants	9 - Prescription Drug																																																		
5 - Vitreous	5 - Vitreous	5 - Hallucinogens	98 - Other (explain in narrative)																																																		
9 - Refused	9 - Refused																																																				



**INVESTIGATING OFFICER'S REPORT OF MOTOR VEHICLE ACCIDENT  
CODE SHEET**

Work Zone Related?	Harmful Events	
<b>Work Zone Activity</b>	<b>Sequence of Events --- Most harmful Event --- First Harmful Event</b>	
1 - Construction 2 - Maintenance 3 - Utility 98 - Other (explain in narrative) 99 - Unknown	<u><b>Pre-crash events:</b></u> 1 - Ran off road, right 2 - Ran off road, straight 3 - Ran off road, left 4 - Crossed centerline (undivided) 5 - Crossed median (divided) 6 - Evasive action (swerve, panic braking, avoidance) 7 - Downhill runaway 8 - Cargo/equipment loss or shift 9 - Equipment failure (tires, brakes, etc.) 10 - Towed portion came apart (separation of units) 11 - Loss of traction 12 - Trailer fishtailing or swaying 13 - Animal (avoided hitting) 94 - Other pre-crash (explain in narrative)	<u><b>Collision with fixed object:</b></u> 40 - Bridge overhead structure 41 - Bridge pier or support 42 - Bridge/bridge rail parapet 43 - Curb/island/raised median 44 - Ditch 45 - Embankment 46 - Ground 47 - Culvert/pipe opening 48 - Guardrail - face 49 - Guardrail - end 50 - Concrete traffic barrier (median or right side) 51 - Other traffic barrier (explain in narrative) 52 - Cable barrier 53 - Impact attenuator/crash cushion 54 - Utility pole/light support 55 - Traffic sign support 56 - Traffic signal support 57 - Other post/pole/support (explain in narrative) 58 - Fire hydrant 59 - Mailbox 60 - Tree 61 - Landscape/shrubbery 62 - Snow bank 63 - Fence 64 - Wall 65 - Building 97 - Other fixed object (explain in narrative)
<b>Location</b>	<u><b>Non-collision events:</b></u> 20 - Overturn/rollover 21 - Jackknife 22 - Non-contact vehicle (phantom) 23 - Vehicle went airborne 24 - Fell/jumped from vehicle 95 - Other non-collision (explain in narrative)	<u><b>Miscellaneous events:</b></u> 70 - Fire/explosion 71 - Immersion 72 - Hit and run 73 - Eluding law enforcement 74 - Gas inhalation/asphyxiation 75 - Vehicle out of gear/rolled 98 - Other (explain in narrative) 99 - Unknown
1 - Before work zone warning sign 2 - Advance warning area 3 - Transition area 4 - Within or adjacent to work activity 5 - Termination area 98 - Other (explain in narrative) 99 - Unknown	<u><b>Collision with:</b></u> 30 - Thrown or falling object 31 - Animal 32 - Non-motorist (see non-motorist section - NOT a unit) 33 - Vehicle in traffic 34 - Re-entering roadway 35 - Parked motor vehicle 36 - Work zone maintenance equipment 37 - Railway vehicle/train 38 - Struck/struck by object/cargo/person from other vehicle 96 - Other non-fixed object (explain in narrative)	
<b>Type</b>		
1 - Lane closure 2 - Lane switch/crossover 3 - Work on shoulder or median 4 - Intermittent or moving work 98 - Other (explain in narrative) 99 - Unknown		
<b>Workers Present?</b>		
1 - Workers only 2 - No workers present 3 - Workers and officer present 4 - Law enforcement only 5 - No one present 98 - Other (explain in narrative) 99 - Unknown		
Roadway Characteristics		
<b>Contributing Circumstances, Environment</b>	<b>Type of Roadway Junction/Feature</b>	<b>Traffic Controls</b>
1 - None apparent 2 - Weather conditions 3 - Visual obstruction 4 - Non-motorist action 5 - Glare 6 - Animal in roadway 7 - Severe crosswind 98 - Other (explain in narrative) 99 - Unknown	<u><b>Non-intersection:</b></u> 1 - Non-junction/no special feature 2 - Bike lanes 3 - Railroad grade crossing 4 - Driveway access (within) 5 - Driveway access (related, not in) 6 - Alley 7 - Crossover-related 96 - Other non-intersection (explain in narrative)	1 - No controls present 2 - Traffic signals 3 - Flashing traffic control signal 4 - Stop signs 5 - Yield signs 6 - No passing zone (marked) 7 - Warning sign 8 - School zone signs 9 - Railway crossing device 10 - Traffic director (person) 11 - Work zone sign 12 - Inoperative (not functioning properly) 13 - Traffic sign missing 98 - Other (explain in narrative) 99 - Unknown
<b>Contributing Circumstances, Roadway</b>	<u><b>Intersection-related:</b></u> 10 - Roundabout 11 - Traffic circle 12 - Four-way intersection 13 - T-intersection 14 - Y-intersection 15 - Five points or more 16 - L-intersection 17 - Shared use path or trail 18 - Intersection with ramp 97 - Other intersection (explain in narrative)	<b>Horizontal Alignment (curve):</b>
1 - None apparent 2 - Surface condition (e.g., wet, icy) 3 - Debris 4 - Ruts, holes, bumps 5 - Work Zone (roadway-related) 6 - Slippery, loose, or worn surface 7 - Obstruction in roadway 8 - Traffic control obscured 9 - Shoulders (none, low, soft, high) 10 - Non-highway work 11 - Traffic backup, prior crash 12 - Traffic backup, regular congestion 13 - Traffic backup, prior non-recurring incident 14 - Disabled vehicle 98 - Other (explain in narrative) 99 - Unknown	<u><b>Interchange-related:</b></u> 20 - On-ramp merge area 21 - Off-ramp, diverge area 22 - On-ramp 23 - Off-ramp 24 - Mainline, between ramps 98 - Other interchange (explain in narrative) 99 - Unknown	1 - Straight 2 - Traversing curve to left 3 - Traversing curve to right 98 - Other (explain in narrative) 99 - Unknown
		<b>Vertical Alignment (grade):</b>
		1 - Level 2 - At crest 3 - Traversing uphill 4 - Traversing downhill 5 - At sag (bottom of hill) 98 - Other (explain in narrative) 99 - Unknown



INVESTIGATING OFFICER'S REPORT OF MOTOR VEHICLE ACCIDENT CODE SHEET

Injury/Protective Devices																											
<p><b>Injury Status</b></p> <p>1 - Fatal 2 - Suspected serious/incapacitating 3 - Suspected minor/non-incapacitating 4 - Possible (complaint of pain/injury) 5 - Uninjured 7 - Fatal, not crash-related 9 - Unknown</p>	<p><b>Seating Position</b></p> <table border="1" style="margin: auto;"> <tr> <td style="width: 30px; height: 30px; text-align: center;">1</td> <td style="width: 30px; height: 30px; text-align: center;">2</td> <td style="width: 30px; height: 30px; text-align: center;">3</td> <td style="width: 30px;"></td> </tr> <tr> <td style="text-align: center;">4</td> <td style="text-align: center;">5</td> <td style="text-align: center;">6</td> <td style="text-align: center;">1<sup>st</sup> Row</td> </tr> <tr> <td style="text-align: center;">7</td> <td style="text-align: center;">8</td> <td style="text-align: center;">9</td> <td style="text-align: center;">2<sup>nd</sup> Row</td> </tr> <tr> <td style="text-align: center;">10</td> <td style="text-align: center;">11</td> <td style="text-align: center;">12</td> <td style="text-align: center;">3<sup>rd</sup> Row</td> </tr> <tr> <td style="text-align: center;">13</td> <td style="text-align: center;">14</td> <td style="text-align: center;">15</td> <td style="text-align: center;">4<sup>th</sup> Row</td> </tr> <tr> <td colspan="3"></td> <td style="text-align: center;">5<sup>th</sup> Row</td> </tr> </table>		1	2	3		4	5	6	1 <sup>st</sup> Row	7	8	9	2 <sup>nd</sup> Row	10	11	12	3 <sup>rd</sup> Row	13	14	15	4 <sup>th</sup> Row				5 <sup>th</sup> Row	<p><b>Occupant Protection</b></p> <p>1 - Not applicable 2 - None used 3 - Shoulder and lap belt used 4 - Lap belt only used 5 - Shoulder belt only used 6 - Child safety seat (forward-facing) 7 - Child safety seat (rear-facing) 8 - Child safety seat (type unknown) 9 - Booster seat 10 - Helmet (DOT compliant) 11 - Helmet (other) 98 - Other (explain in narrative) 99 - Unknown</p>
1	2	3																									
4	5	6	1 <sup>st</sup> Row																								
7	8	9	2 <sup>nd</sup> Row																								
10	11	12	3 <sup>rd</sup> Row																								
13	14	15	4 <sup>th</sup> Row																								
			5 <sup>th</sup> Row																								
<p><b>Died at Scene/Enroute</b></p> <p>1 - Not applicable 2 - Died at scene 3 - Died enroute 4 - Died at hospital 5 - Died later (w/in 30 days) 98 - Other (explain in narrative) 99 - Unknown</p>	<p>16 - In 6th row or greater 17 - In enclosed passenger/cargo area 18 - In unenclosed passenger/cargo area 19 - Sleeper 20 - Trailing unit 21 - Riding on exterior of vehicle 22 - Hanging onto vehicle 23 - Passenger of motorcycle/moped/ATV 98 - Other vehicle-related (explain in narrative) 99 - Unknown</p>		<p><b>Airbag Deployment</b></p> <p>1 - Not applicable 2 - Airbag turned off 3 - Not deployed 4 - Deployed front of person 5 - Deployed side of person 6 - Deployed both front/side 7 - Deployed curtain 98 - Other deployment (explain in narrative) 99 - Unknown</p>																								
<p><b>Source of Transport</b></p> <p>1 - Not transported 2 - EMS air 3 - EMS ground 4 - Law enforcement 5 - Parent/spouse/friend 6 - Self 7 - To funeral home/morgue 98 - Other (explain in narrative) 99 - Unknown</p>	<p><b>Trapped/Extricated</b></p> <p>1 - Not trapped/applicable 2 - Extricated by non-mechanical means 3 - Extricated by mechanical means 9 - Unknown</p>		<p><b>Ejection Path</b></p> <p>1 - Not ejected/not applicable 2 - Through front windshield 3 - Through side window 4 - Through side door 5 - Through roof 6 - Through back window 7 - Through back door/tailgate opening 98 - Other (explain in narrative) 99 - Unknown</p>																								
<p><b>Non-motorist (see non-motorist section below)</b></p> <p>1 - Pedestrian 2 - Pedalcyclist (bicycle, tricycle, unicycle, pedal car) 3 - Pedalcycle passenger 4 - In or on building 5 - Horse and Buggy 6 - Skater, personal conveyance, wheelchair 98 - Other non-motorist (explain in narrative) 99 - Unknown</p>	<p><b>Ejection</b></p> <p>1 - Not applicable 2 - Not ejected 3 - Partially ejected 4 - Totally ejected 9 - Unknown</p>	<p><b>Type of Primary Incident</b></p> <p>1 - Vehicle Crash 2 - Traffic Stop 3 - Roadway Debris 4 - Motorist Assist 5 - Other (Explain in narrative)</p>																									
Non-Motorist																											
<p><b>Location (prior to impact)</b></p> <p><u>Intersection:</u></p> <p>1 - Within marked crosswalk 2 - Within unmarked crosswalk 3 - Not within crosswalk 4 - Unknown location</p> <p><u>Non-intersection (midblock):</u></p> <p>5 - Within marked crosswalk 6 - Within unmarked crosswalk 7 - Not within crosswalk 8 - Unknown location</p> <p>9 - Parking lane/zone 10 - Pedalcycle lane 11 - Sidewalk 12 - Driveway access 13 - Shared path or trail 14 - Shoulder/roadside 15 - Median/crossing island 16 - Non-trafficway 17 - Travel lane, other location</p> <p>98 - Other (explain in narrative) 99 - Unknown</p>	<p><b>Action (prior to crash)</b></p> <p>1 - Entering or crossing roadway 2 - Waiting to cross roadway 3 - Going to/coming from school 4 - Working in trafficway 5 - Approaching or leaving vehicle 6 - Entering/exiting vehicle 7 - Playing on or working on vehicle 8 - Disabled vehicle-related/pushing vehicle</p> <p><u>Movement:</u></p> <p>10 - Along roadway with traffic 11 - Along roadway against traffic 12 - Along roadway (direction unknown) 13 - On shoulder/median 14 - On sidewalk</p> <p>98 - Other (explain in narrative) 99 - Unknown</p>	<p><b>Condition</b></p> <p>1 - Apparently normal 2 - Emotional (e.g., depressed, angry) 3 - Asleep/fatigued 4 - Illness/fainted 5 - Medical condition (seizure, reaction) 6 - Under the influence of alcohol 7 - Under the influence of drugs/meds 8 - Physical impairment 9 - Walks with a cane/crutches 10 - Paraplegic/wheelchair restricted 11 - Impaired due to previous injury 12 - Hearing impaired/deaf 13 - Visually impaired/blind</p> <p>98 - Other (explain in narrative) 99 - Unknown</p>	<p><b>Contributing Circumstances</b></p> <p>1 - No improper action 2 - Not visible (dark clothing) 3 - Improper crossing 4 - Darting/dashing 5 - Inattentive (talking, eating, texting) 6 - Riding/walking on wrong side of road 7 - Failure to obey traffic signs, signals, or officer 8 - Failure to yield right-of-way 9 - Failure to have lights on when required 10 - Operating without required equipment 11 - Improper riding (more riders than seats) 12 - Improper turn/merge 13 - Improper passing 14 - Passing with insufficient distance or inadequate visibility 15 - Improper/erratic lane changing 16 - Failure to remain in proper lane 17 - Operating in a reckless, erratic, careless, negligent manner 18 - Improper exit/entry from trafficway 19 - In roadway improperly (standing, sitting, lying, working, playing) 20 - Disabled vehicle-related (working on, pushing, leaving/approaching) 21 - Entering/exiting parked/standing vehicle 98 - Other (explain in narrative) 99 - Unknown</p>																								
	<p><b>Safety Equipment</b></p> <p>1 - Not applicable 2 - None 3 - Helmet 4 - Reflective clothing 5 - Lighting</p>		<p>6 - Protective pads 7 - Multi-equipment (explain in narrative) 98 - Other (explain in narrative) 99 - Unknown</p>																								



# APPENDIX A

## Manner of crash/collision examples

### CODE 1 - NON-COLLISION

---

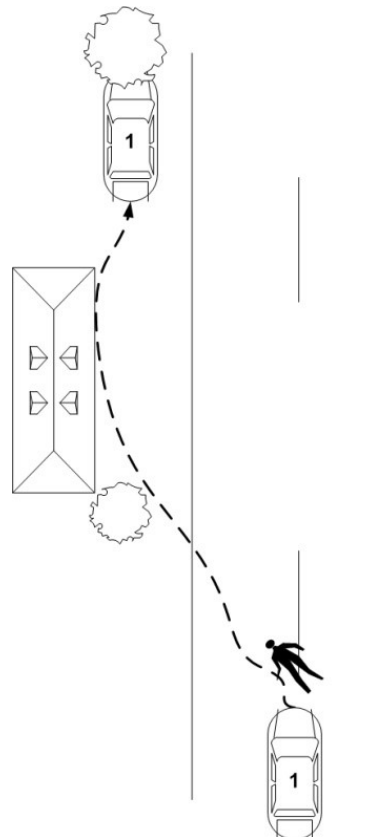
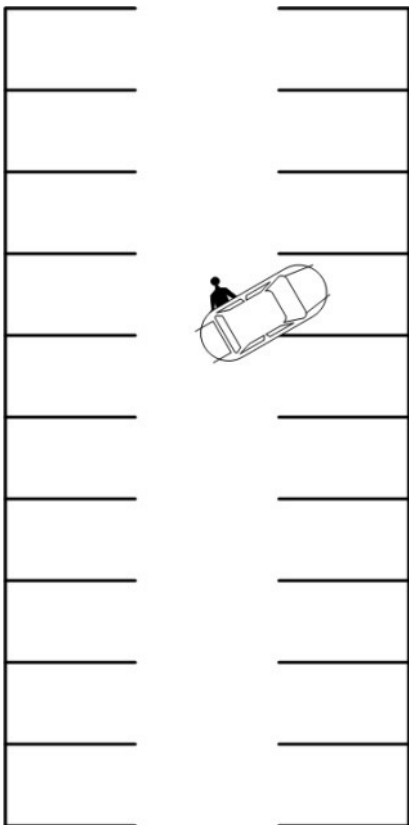
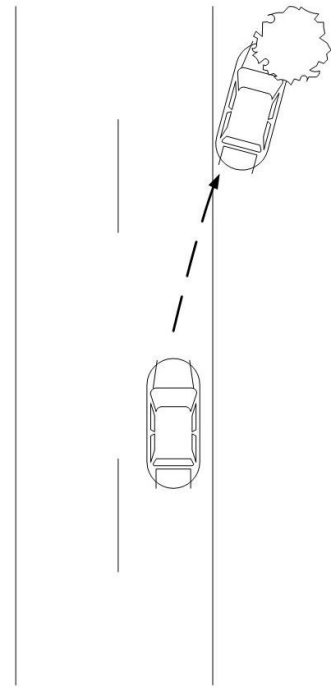
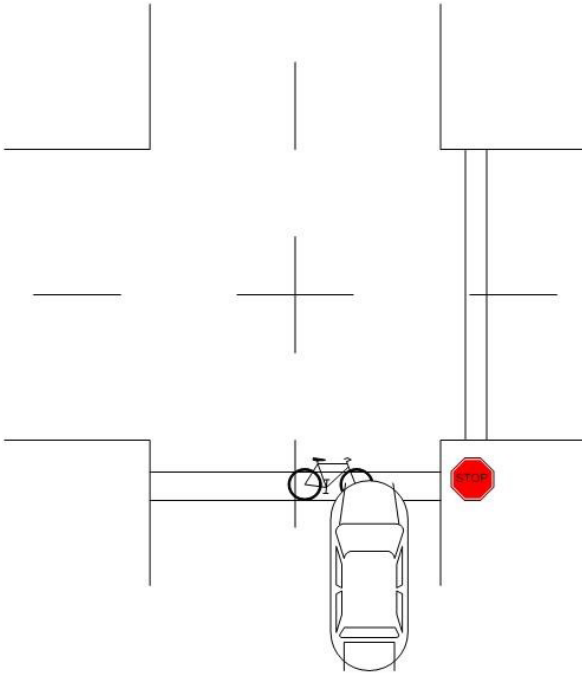

### CODE 2 - HEAD-ON

---

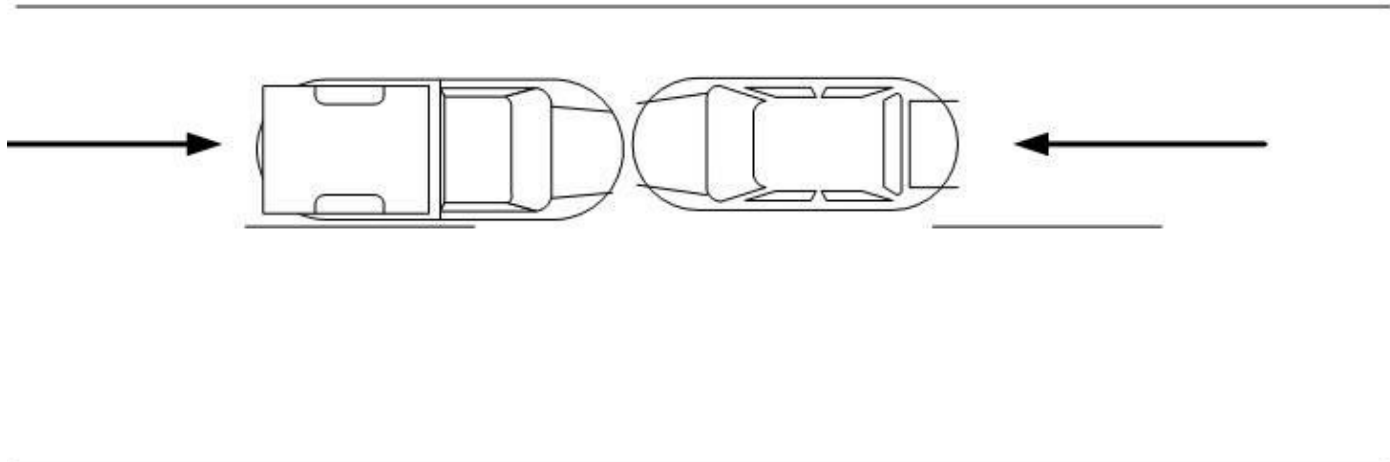

### CODE 3 - REAR-END

---

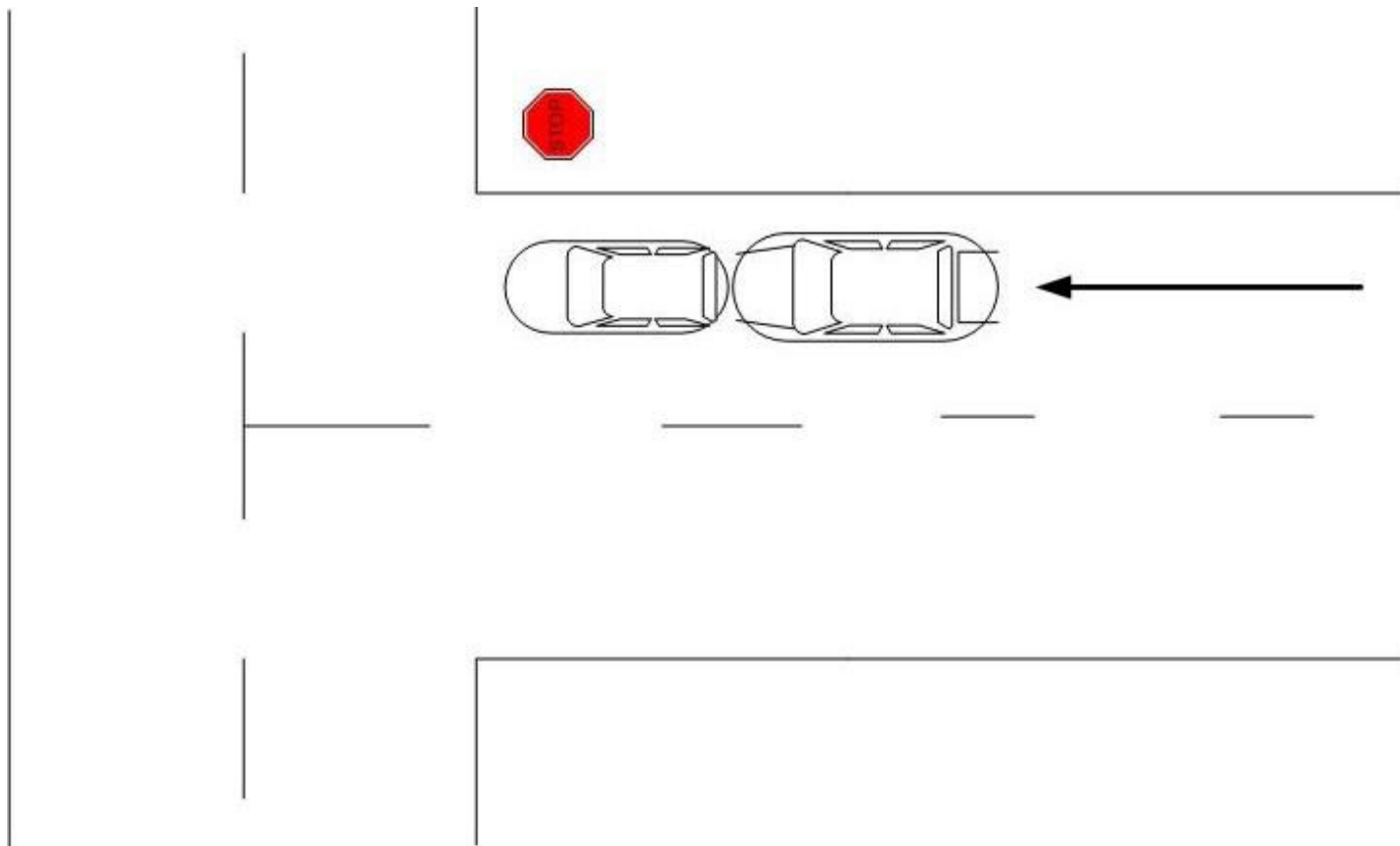

## CODE 4 – ANGLE, ONCOMING LEFT TURN

---

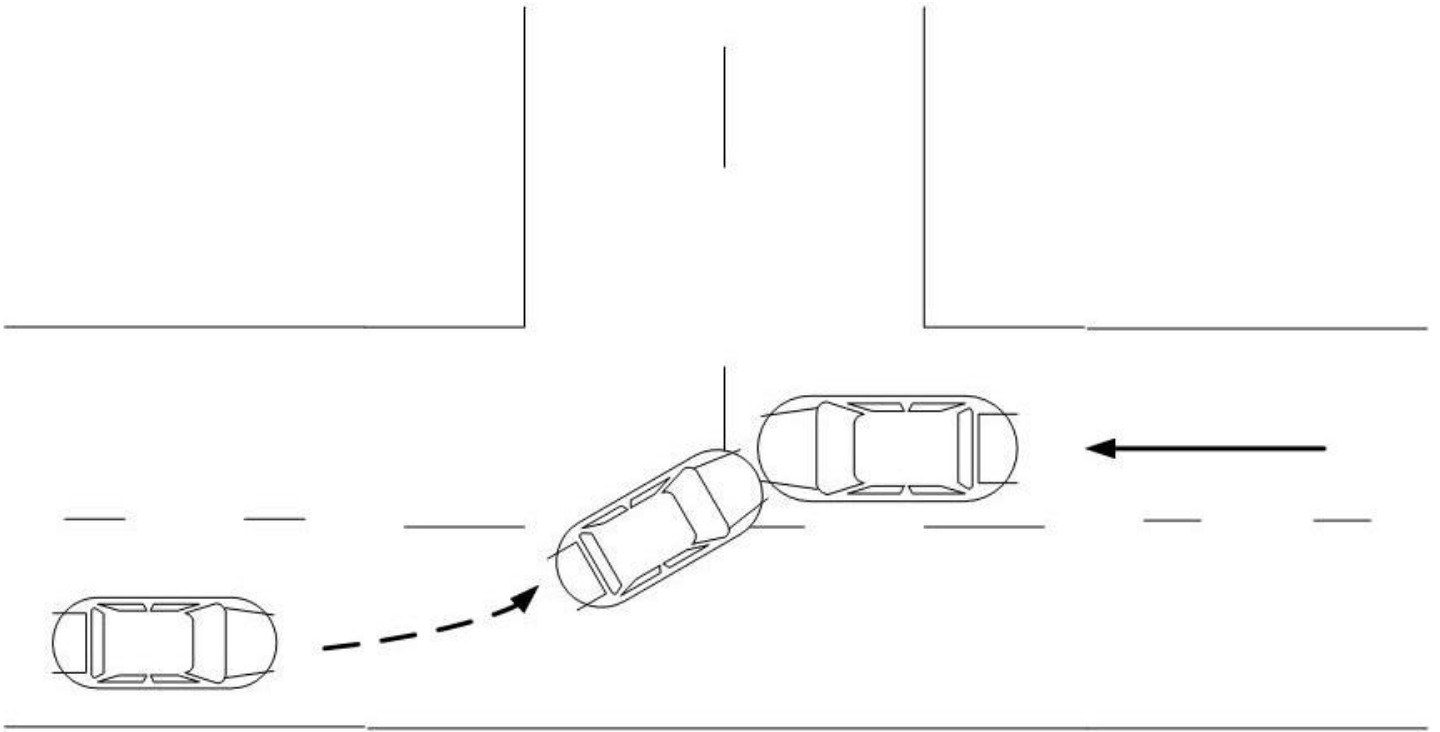

## CODE 5 – BROADSIDE

---

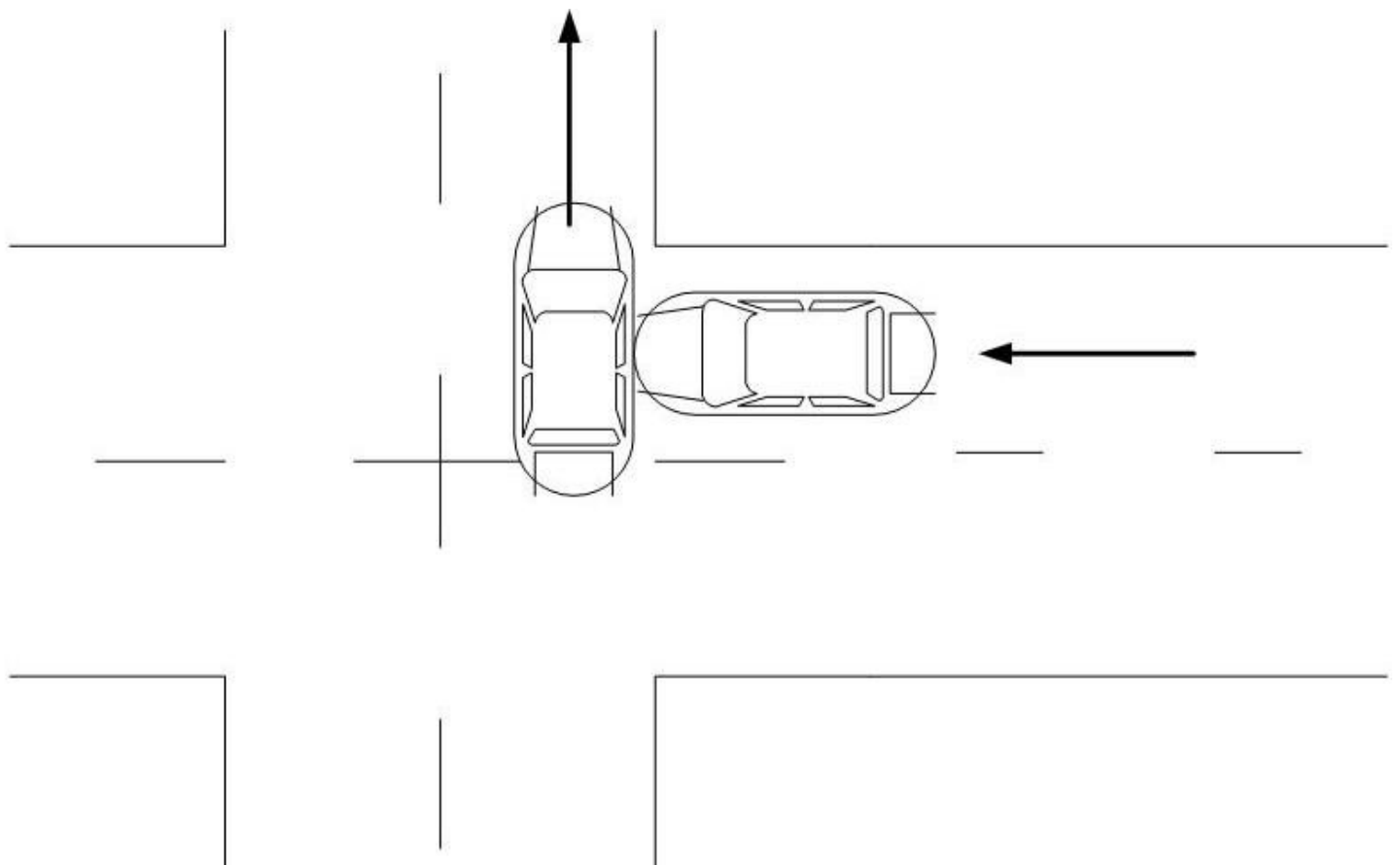

## CODE 6 – SIDESWIPE, SAME DIRECTION

---

---

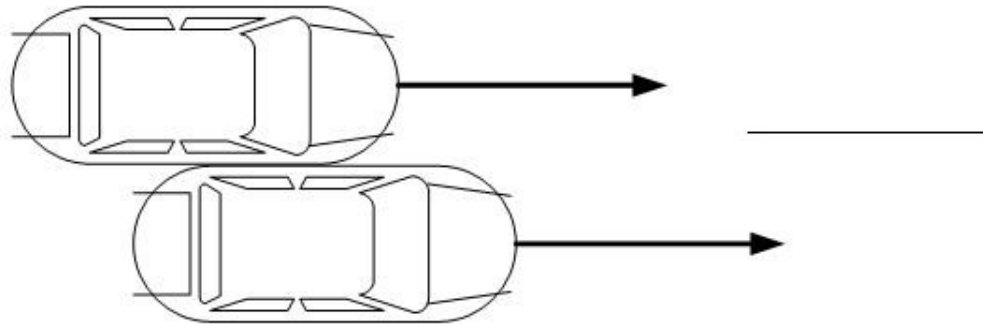

## CODE 7 – SIDESWIPE, OPPOSITE DIRECTION

---

---

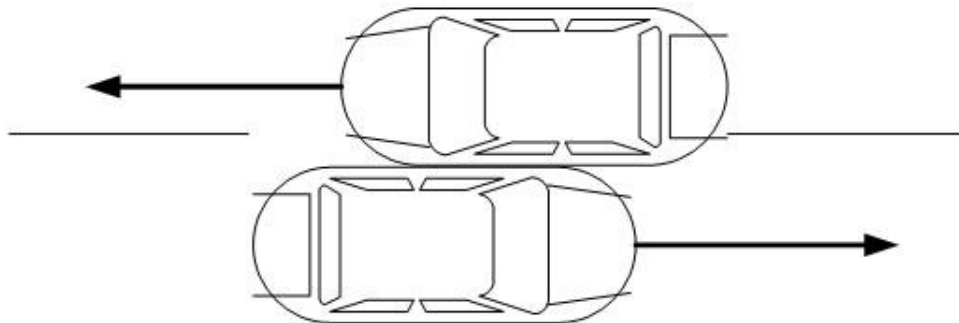

## CODE 8 – REAR TO REAR

---

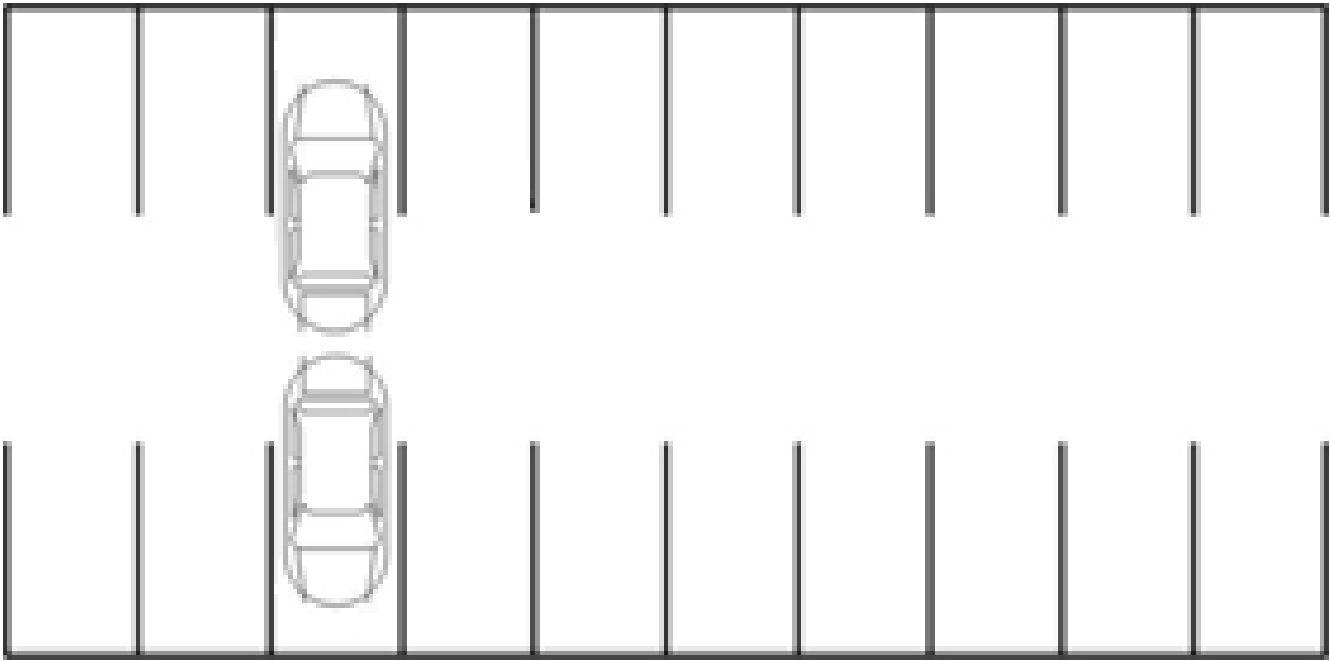

## CODE 9 – REAR TO SIDE

---

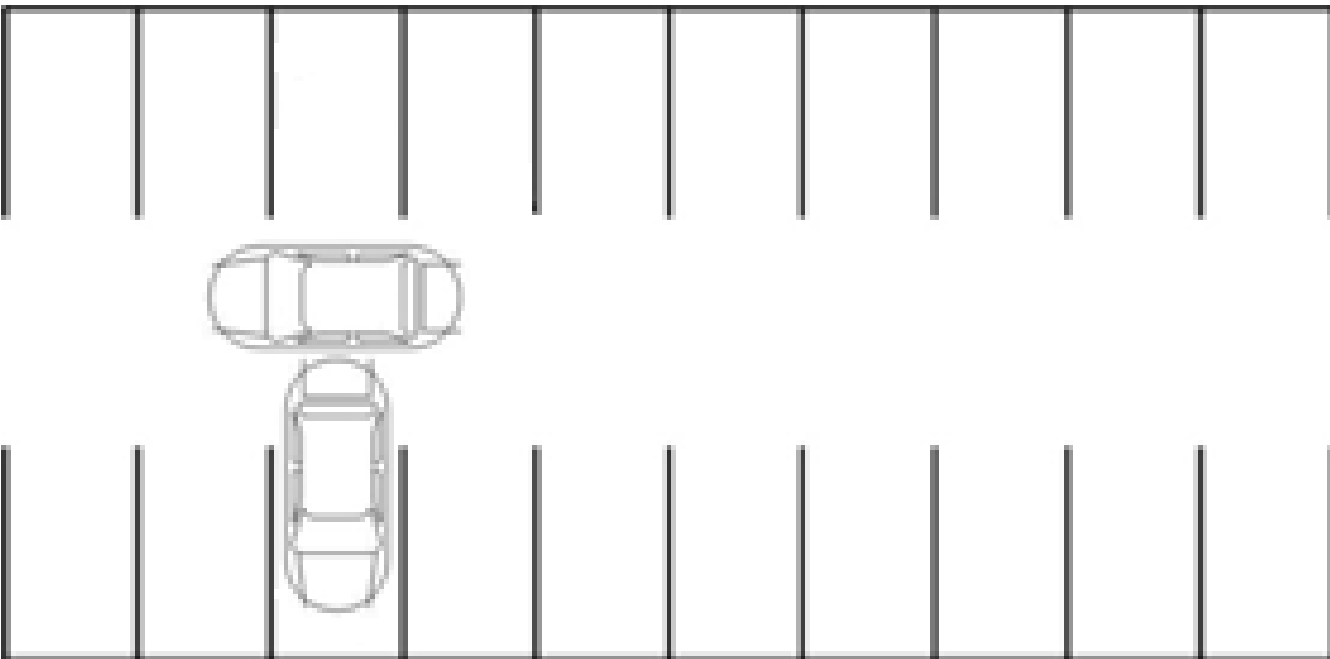



# APPENDIX B

## FAQ

### WHEN IS A UNIT TURNING AND WHEN IS IT CHANGING LANES?

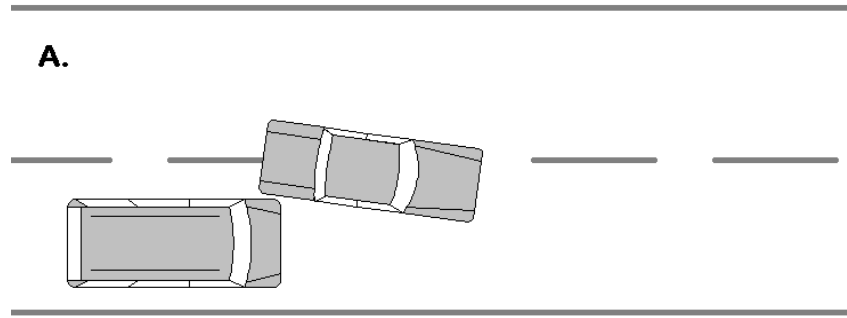

Often when a vehicle is changing lanes, a temptation is to say that it is executing a turn, which is incorrect. A lane change can usually be described as when a unit attempts to move from one lane to another without the intent to leave the roadway by entering a driveway or another road. Unless making a U-turn, a unit cannot be considered turning if there are no roadway features to allow it off the road.

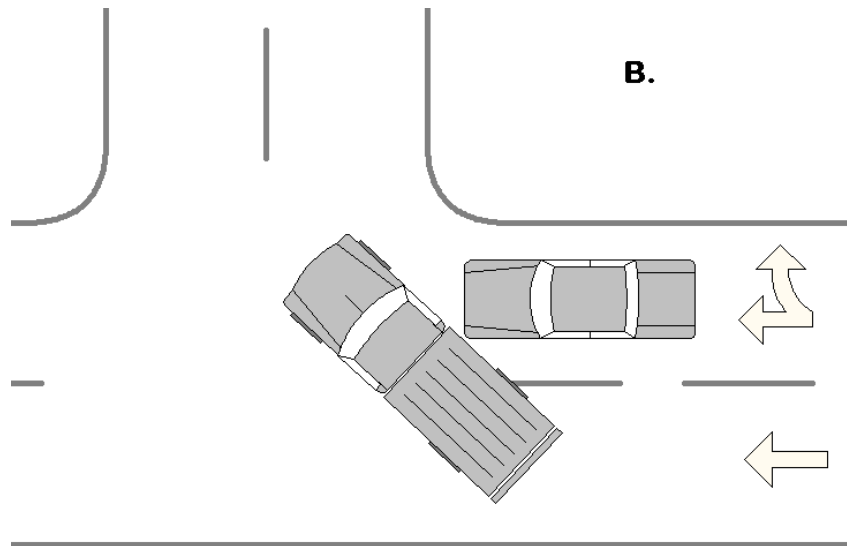

A turn occurs when a driver's intent is to transfer from one roadway to another, such as at an intersection or driveway. Example B is illustrating a truck making an improper turn at an intersection. Although the truck is also traveling across another lane of travel, it is attempting to proceed north on a different roadway than it was previously traveling making it a turn (improper) and not just a lane change.

## IS A TRAILER A UNIT?

---

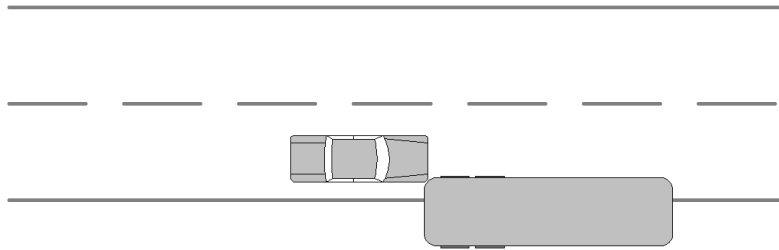

In the situation above, a semitrailer was parked on the side of the road, partially in the travelled portion of the roadway and was subsequently struck by a car. A parked trailer of any kind that is not attached to a power unit, is not considered its own unit, but should be recorded as property damage. Remember, only a motor vehicle can be considered a unit and a lone trailer does not qualify.

An exception to this rule may occur if, for example, a livestock trailer being pulled by a pickup truck becomes unattached and rolls into a car. In this situation, even though the trailer wasn't attached at the moment of impact, the truck and trailer should still be treated as the same unit.

## HOW DO I REPORT AN UNOCCUPIED RUNAWAY VEHICLE?

---

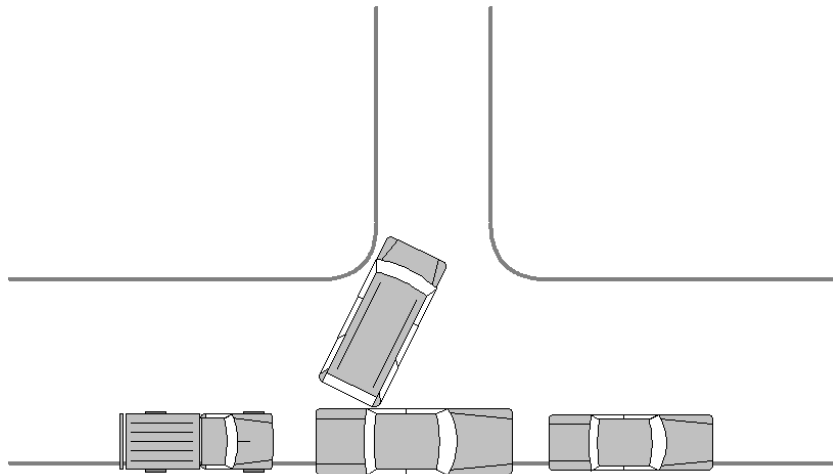

**“Narrative” section example:** While parked in owner’s driveway, a minivan slips out of gear and rolls down the driveway, colliding with a parked vehicle on the opposite side of the road.

There are only two major differences between a crash like this and if both vehicles were occupied is that the out-of-control unit’s driver will be ‘unknown’ and code 98 **“Other”** should be entered in the **“Vehicle Action”** field.

## HOW DO I REPORT A RUNAWAY TIRE STRIKING ANOTHER VEHICLE?

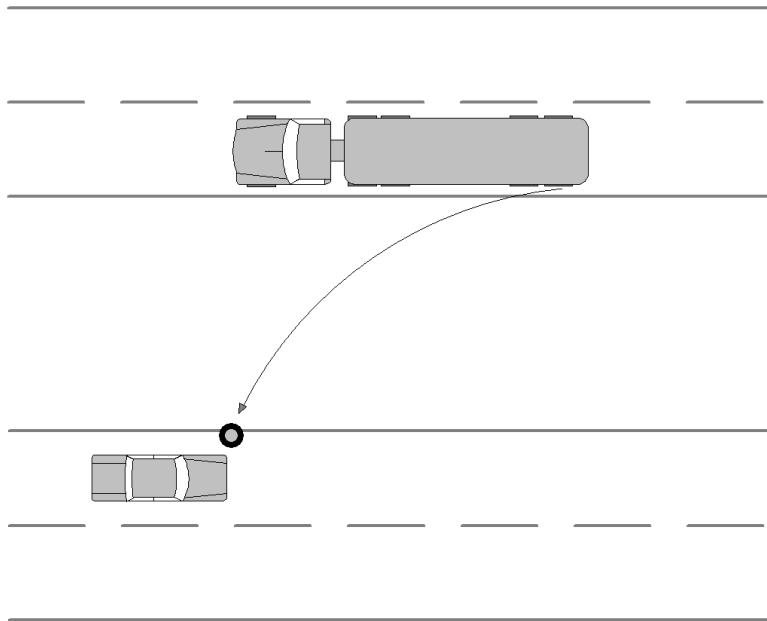

In a situation like this, as strange as it may seem, the tire should still be treated as though it's a part of the vehicle from which it came. So, for the example above, the manner of crash/collision is a sideswipe, opposite direction. The same thing should be done in instances where a vehicle loses cargo and it strikes another vehicle – treat the cargo as if it's still a part of the vehicle carrying it.

## IMPROPER USE OF EVENT – CODE 33 “VEHICLE IN TRAFFIC”

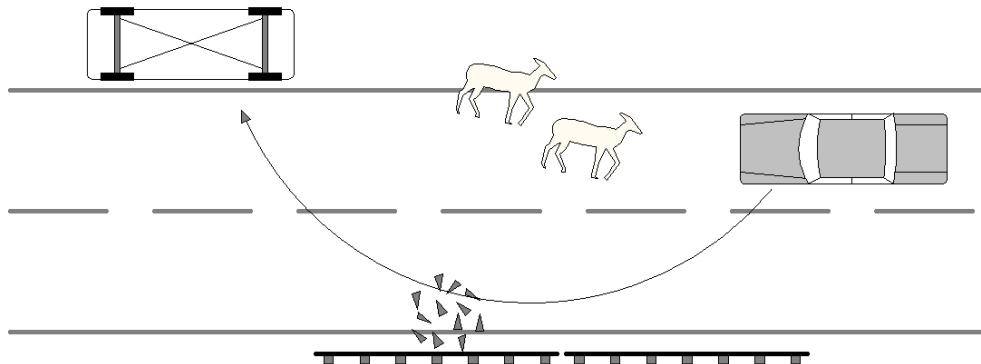

In this example, the unit swerved to miss some deer, struck a guardrail, and then traveled into the ditch where it overturned. A common mistake with single-vehicle crashes is to regard any contact between the vehicle and other objects as a collision using code 33 “**Vehicle in traffic**” (see “**Sequence of Events**” section on [page 34](#)).

A correct sequence of events could be coded as listed below.

- Code 6**            Evasive action (swerve, panic braking, etc.)
- Code 48**        Guardrail face
- Code 1**           Ran off road, right
- Code 20**        Overturn/Rollover

## HOW DO I REPORT A HIT AND RUN CRASH WHEN I KNOW NOTHING ABOUT THE STRIKING VEHICLE?

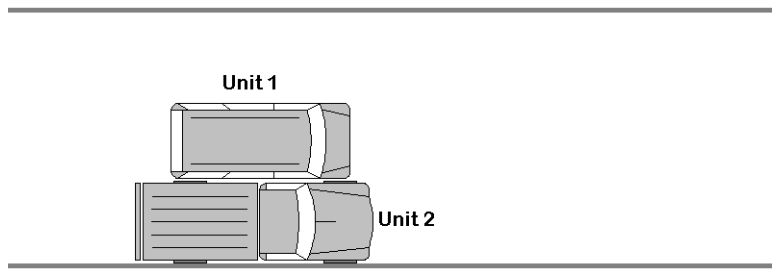

**“Narrative” section example:** At some point during the night, unknown “unit 1” struck legally parked “unit 2” outside owner’s residence.

In a situation like this, there’s not a lot of information that can be recorded for the run vehicle but there are still some points to keep in mind, including:

1. This is a two-vehicle crash so there should be two units.
2. At least one person was driving the run vehicle, so enter 1 in the **“Total Occupants”** field to validate the form.
3. Unit 1 should have code 35 **“Collision with parked vehicle”** entered in their **“Sequence of Events”** followed by code 72 **“Hit and run.”**
4. Unit 2 “Sequence of Events” would be code 33 **“Collision with vehicle in traffic.”**

## WHEN THE CORRECT MANNER OF CRASH DOESN’T MAKE SENSE

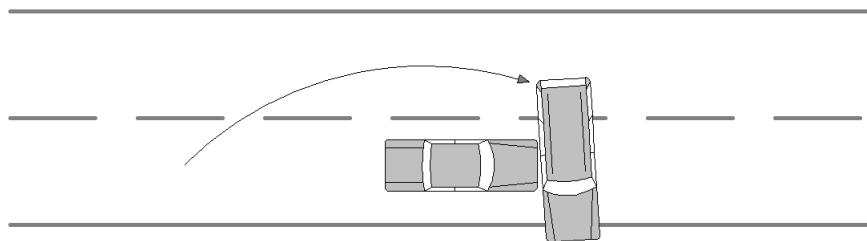

**Situation:** Both vehicles are traveling east on a partially ice-covered roadway when the trailing vehicle attempts to pass. During the maneuver, the passing vehicle loses control, rotating and sliding in front of the other vehicle, at which point a collision occurs.

This is understandably one of the most debated topics officers encounter when investigating crashes. The most often argued point is to record the facing directions (which determines the manner of crash) of the vehicles upon impact. This does make sense; however, for analysis purposes the Iowa DOT and other agencies need to know the correct initial travel direction of each vehicle immediately prior to the unstable situation. This point causes contention due to the fact that quite often, the manner of crash doesn’t seem to make sense, such as in the above example.

In this case, the **“Manner of Crash”** is code 6 **“Sideswipe, same direction.”** Why, even though the two vehicles obviously collided at a roughly 90-degree angle to each other? Remember, it’s the initial travel direction that determines the manner of crash, not the direction the vehicles are facing. In this situation, both vehicles were traveling in an easterly direction that narrows down the manner of crash option to either rear-end or sideswipe, same direction.

## HOW DO I REPORT ON CRASHES INVOLVING TRAINS?

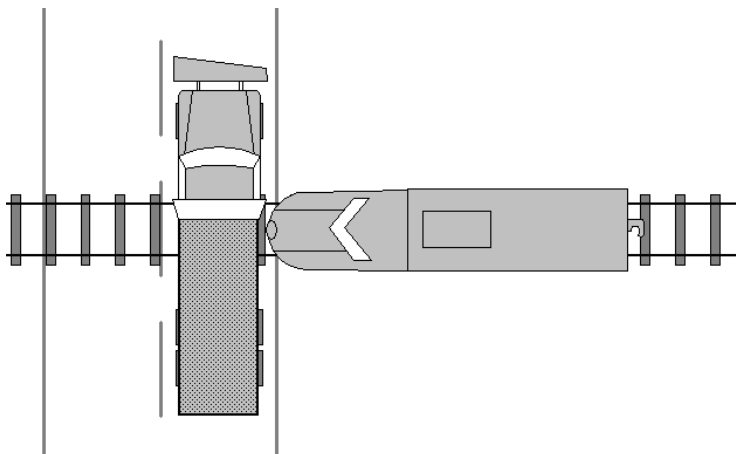

When reporting a crash involving a motor vehicle and a train, the train should be created as a unit but do not enter the train’s conductor or engineer as the driver. Enter the train’s vehicle configuration as code 36 “**Train**” and enter 1 for the “**Total Occupants**” field. In TraCS, answer “**No**” for the first field of the Unit section, “**Is all information known/applicable for this unit?**” That allows the fields that are not needed for the train to be left blank and still validate. If anyone on/in the train is injured, add them in the “**Injured Persons**” under the train unit. The seating position would be “98-Other-vehicle related (explain in narrative).”

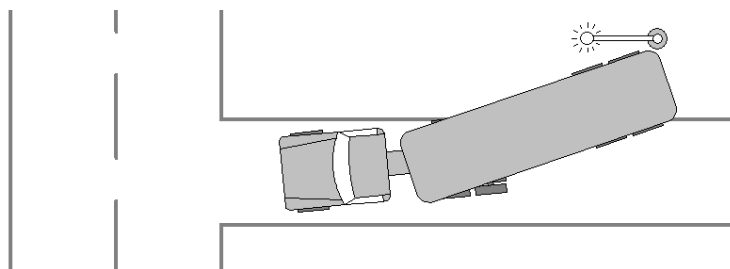

## CRASH WAS ON PRIVATE PROPERTY – SHOULD I REPORT IT?

**“Narrative” section example:** While backing into a private driveway to load corn during harvest time, the unit strikes a yard light and utility pole belonging to the local electric company, knocking the pole and wires to the ground.

Crashes on private property should be reported to the Iowa DOT in the same manner as crashes occurring on public roadways as long as they meet the reportable criteria as described on [page 5](#).

# APPENDIX C

## National Crime Information Center

### Approved Abbreviations

Acura	ACUR	Kia Motors Corp.	KIA
Alfa Romeo	ALFA	Lamborghini	LAMO
American Motors	AMER	Land Rover	LNDR
Aston Martin	ASTO	Lexus	LEXS
Audi	AUDI	Lincoln-Continental	LINC
Austin	AUST	Lotus	LOTU
Bentley	BENT	Maserati	MASE
BMW	BMW	Mazda	MAZD
Buick	BUIC	Mercedes-Benz	MERZ
Cadillac	CADI	Mercury	MERC
Checker	CHEC	Merkur	MERK
Chevrolet	CHEV	MG	MG
Chrysler	CHRY	Mitsubishi	MITS
Citroen	CITR	Nash	NASH
Daewoo	DAEW	Nissan	NISS
Daihatsu	DAIH	Oldsmobile	OLDS
Datsun	DATS	Opel	OPEL
DeSoto	DESO	Packard	PACK
Dodge	DODG	Peugeot	PEUG
Eagle	EGIL	Plymouth	PLYM
Edsel	EDSE	Pontiac	PONT
Ferrari	FERR	Porsche	PORS
Fiat	FIAT	Rambler	RAMB
Ford	FORD	Renault	RENA
General Motors Corp.	GMC	Rolls-Royce	ROL
GEO	GEO	Rover	ROV
Honda	HOND	Saab	SAA
Hudson	HUDS	Saturn	STRN
Hyundai	HYUN	Studebaker	STU
Imperial	IMPE	Subaru	SUBA
Infiniti	INFI	Suzuki	SUZI
Isuzu	ISU	Toyota	TOYT
Jaguar	JAGU	Triumph	TRIU
Jeep	JEEP	Volkswagen	VOLK
Kaiser	KAIS	Volvo	VOLV



# APPENDIX D

## Color Code

COLOR	ABBREVIATION	COLOR	ABBREVIATION
Aluminum	SIL	Green, light	LGR
Amethyst (purple)	AME	Ivory	CRM
Beige	BGE	Lavender (purple)	LAV
Black	BLK	Maroon	MAR
Blue	BLU	Mauve (purple)	MVE
Blue, dark	DBL	Multicolored	MUL/COL*
Blue, light	LBL	Orange	ONG
Bronze	BRZ	Pink	PNK
Brown	BRO	Purple	PLE
Burgundy (purple)	MAR	Red	RED
Camouflage	CAM	Silver	SIL
Chrome	COM	Stainless steel	COM
Copper	CPR	Tan	TAN
Cream	CRM	Taupe (brown)	TPE
Gold	GLD	Teal (green)	TEA
Gray	GRY	Turquoise (blue)	TRQ
Green	GRN	White	WHI
Green, dark	DGR	Yellow	YEL

# APPENDIX E

## Officer in the Line of Duty Form

### SAMPLE

---

Note: Email the Officer in the Line of Duty Form to: [accident.support@iowadot.us](mailto:accident.support@iowadot.us)

Date: \_\_\_\_\_

Iowa Department of Transportation  
Motor Vehicle Division  
P.O. Box 9204  
Des Moines, IA 50306-9204

To Whom It May Concern:

This letter is official notice, as required by Iowa Code 321.267A that an emergency responder employed by the \_\_\_\_\_ (Agency Name) was involved in a line of duty motor vehicle accident. Following are the required notice details.

### OFFICER'S INFORMATION

Officer's name \_\_\_\_\_

Date of birth \_\_\_\_\_

Driver's license number and state of issue \_\_\_\_\_

Case number \_\_\_\_\_

Name of agency taking report \_\_\_\_\_

Date of crash \_\_\_\_\_

Accident location \_\_\_\_\_

Vehicle identification number (VIN) driven by responder \_\_\_\_\_

This crash was reviewed and occurred in the line of duty:

\_\_\_\_\_ While operating an official government vehicle.

\_\_\_\_\_ While operating a personally owned vehicle.

I certify under penalty of perjury and pursuant to the laws of the State of Iowa that the preceding is true and correct.

\_\_\_\_\_  
Officer's supervisor

# APPENDIX F

## Work Zone Area

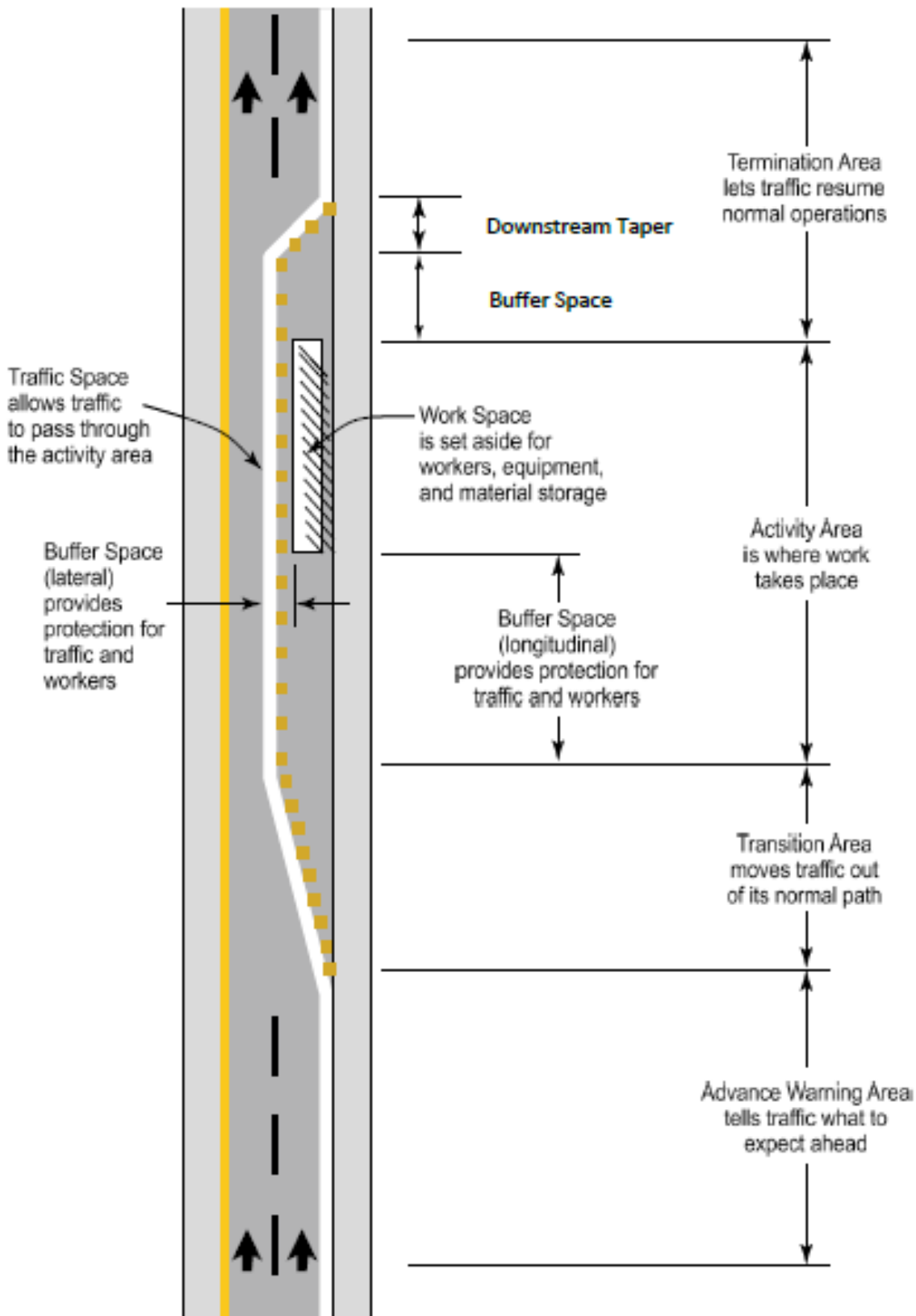

# APPENDIX G

## Light Conditions

### TIME AND LIGHT CONDITIONS

If MONTH is	and TIME is	then LIGHT condition must be
January (CST)	0001-0530	4 or 5
	0900-1530	1
	1900-2400	4 or 5
February (CST)	0001-0530	4 or 5
	0830-1630	1
	1930-2400	4 or 5
March or April (CST)	0001-0430	4 or 5
	0800-1700	1
	2000-2400	4 or 5
April (DST)	0001-0500	4 or 5
	0800-1730	1
	2130-2400	4 or 5
May (DST)	0001-0430	4 or 5
	0730-1900	1
	2200-2400	4 or 5
June (DST)	0001-0430	4 or 5
	0700-1930	1
	2200-2400	4 or 5
July (DST)	0001-0500	4 or 5
	0730-1900	1
	2200-2400	4 or 5
August (DST)	0001-0500	4 or 5
	0800-1900	1
	2200-2400	4 or 5
September (DST)	0001-0530	4 or 5
	0830-1730	1
	2100-2400	4 or 5
October (DST)	0001-0530	4 or 5
	0830-1630	1
	2000-2400	4 or 5
October or November (CST)	0001-0530	4 or 5
	0830-1530	1
	1830-2400	4 or 5
December (CST)	0001-0600	4 or 5
	0900-1530	1
	1830-2400	4 or 5

# APPENDIX H

## Seating Positions

Source for images, tables, and charts shown in this appendix unless otherwise noted:  
*Model Minimum Uniform Crash Criteria, Fourth Edition.*

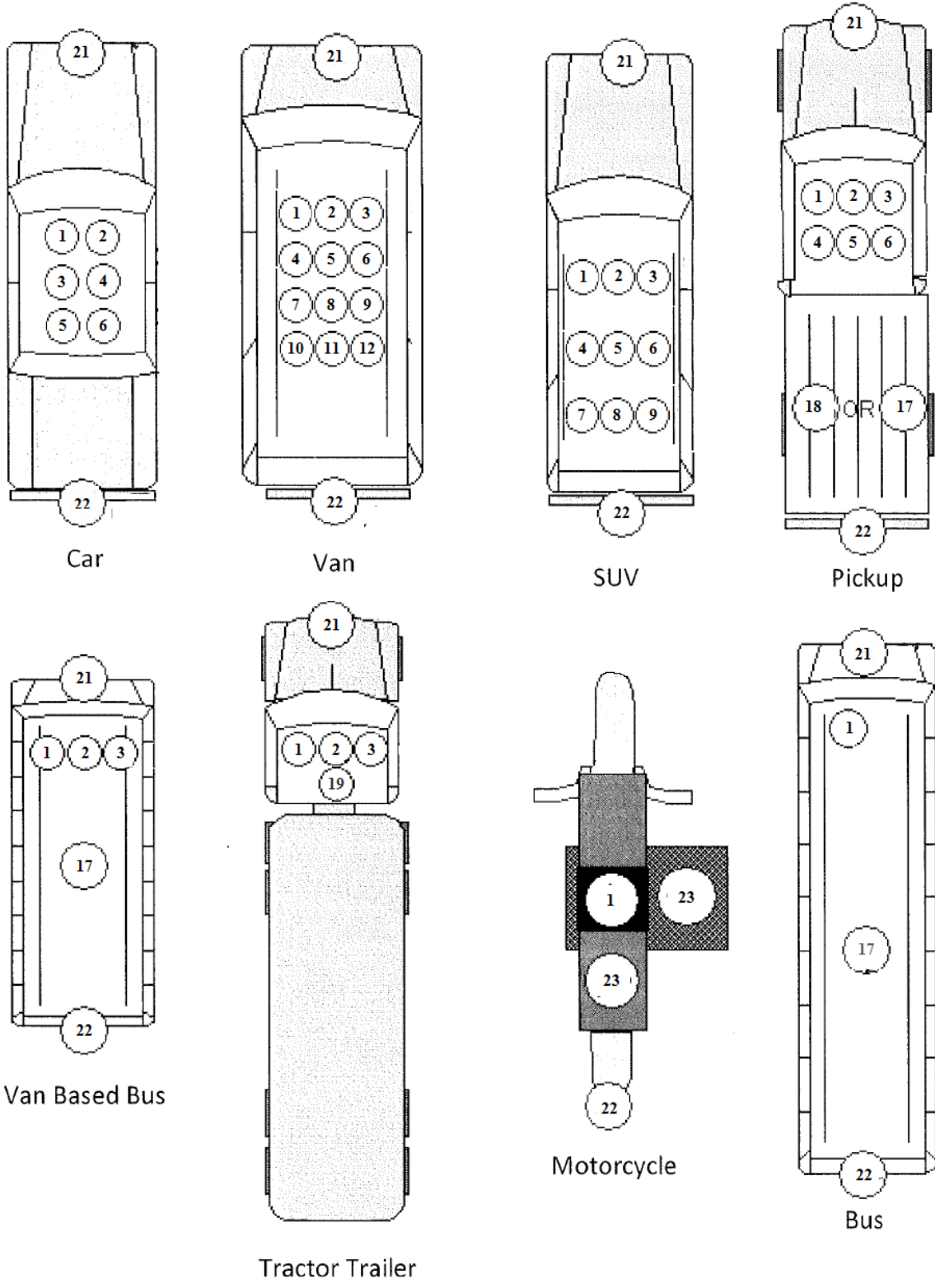

# APPENDIX I

## Sequence of Events

Source for images, tables, and charts shown in this appendix unless otherwise noted:  
*Model Minimum Uniform Crash Criteria, Fourth Edition.*

### EXAMPLE 1

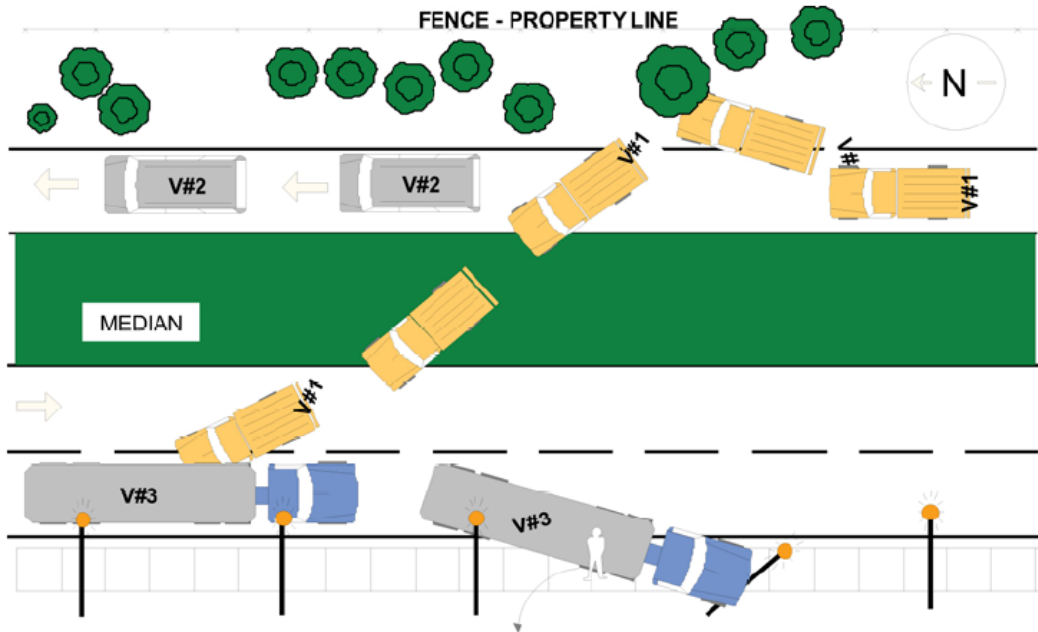

### Narrative

V#1, a pickup, was traveling in the right-hand lane of northbound SR7 following V#2, a van. V#2 slowed suddenly. D#1 did not notice V#2 slowing in time and swerved to the right to avoid striking V#2. V#1 struck a tree off the right side of the road. V#1 veered off the tree and proceeded to cross over the center median grass striking V#3 traveling in the right-hand southbound lane injuring the driver of V#1.

After being struck by V#1, V#3 struck the curb on the right-hand side of the road, crossed over the sidewalk, and struck a pedestrian and then a light pole. V#2 did not know the accident had occurred and kept on driving.

### Vehicle 2 from diagram

No sequence of events would be recorded for this vehicle as it was a “noncontact” vehicle and should not be listed as a Unit in the crash report.

### Vehicle 1 sequence of events

60	Collision with tree (first harmful event)
1	Ran off road – right
60	Collision with tree
5	Cross median divided
33	Collision with vehicle in traffic
33	Collision with vehicle in traffic (most harmful event)

### Vehicle 3 sequence of events

33	Collision with vehicle in traffic
43	Collision with curb
32	Collision with non-motorists
54	Collision with utility pole/light support
32	Collision with non-motorist (most harmful event)



## EXAMPLE 2

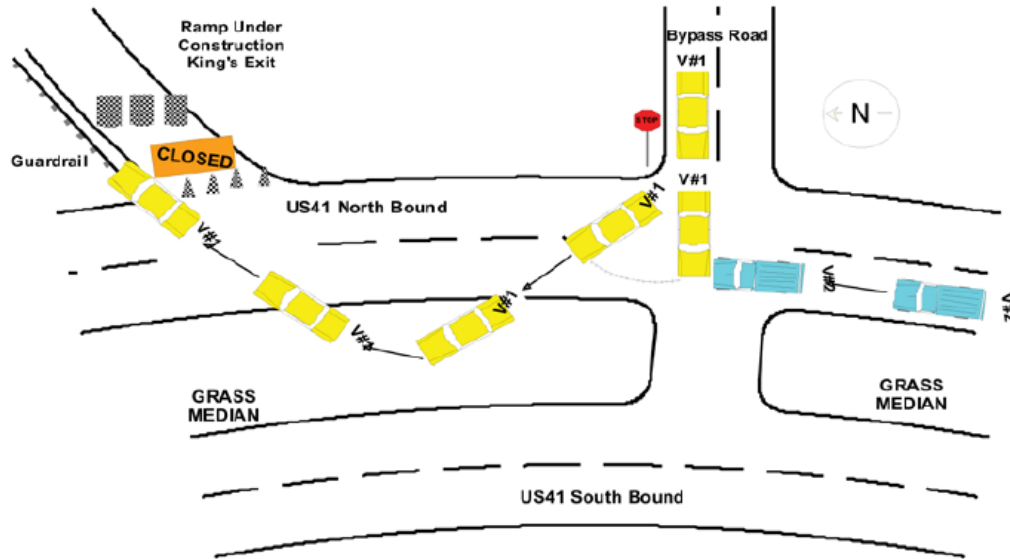

### Narrative

D#1 was stopped at the stop sign on the south end of the bypass road around the King's Mine overpass construction. Upon entering U.S. 41 with the intention of crossing over the northbound lanes and then turning to the south, D#1 failed to see V#2 northbound on U.S. 41. V#2 struck the front driver's side of V#1 causing it to spin clockwise.

D#1 was either unconscious or disoriented. D#1 apparently had her foot on the accelerator and went approximately 1,000 feet to the north in the median and then crossed over northbound U.S. 41.

After crossing the northbound lanes, V#1 started up the ramp at the King's Mine interchange that is currently closed for construction. V#1 went head-on into the guardrail end on the west side ramp.

### Vehicle 1 sequence of events

- 33 Collision with vehicle in traffic (first harmful event)
- 33 Collision with vehicle in traffic
- 3 Ran off roadway – left
- 49 Collision with guardrail – end

### Vehicle 2 sequence of events

- 33 Collision with vehicle in traffic
- 33 Collision with vehicle in traffic (most harmful event)

## EXAMPLE 3

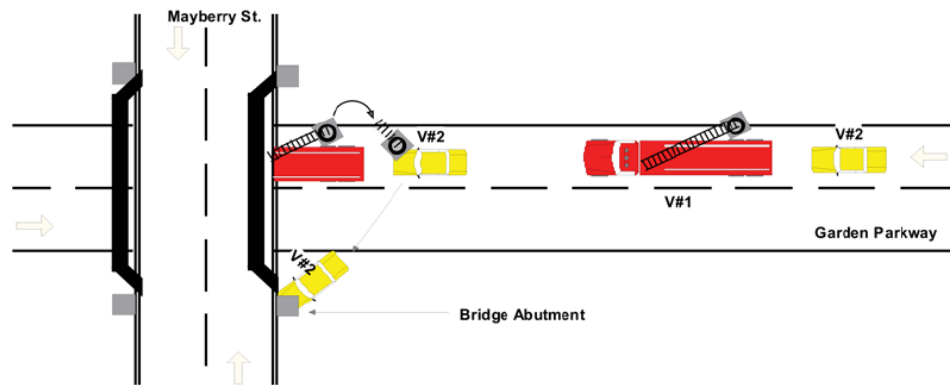

### Narrative

V#1, a fire truck returning from an emergency, was traveling west on Garden Parkway approaching the Mayberry Street underpass when a malfunction in the hydraulic system of its hook and ladder apparatus caused the ladder to raise and swing to the right of the vehicle. When V#1 went under the Mayberry Street overpass the ladder and bucket struck the bottom of the bridge, breaking off the top portion of the ladder. The ladder piece struck the right, front quarter panel of V#2, which was following directly behind V#1. V#2 lost control and struck the underpass bridge abutment on the eastbound side of the road.

### Vehicle 1 sequence of events

- 40 Collision with bridge overhead structure (first harmful event)
- 9 Equipment failure
- 40 Collision with bridge overhead structure
- 8 Cargo/Equipment loss or shift
- 33 Collision with vehicle in traffic
- 33 Collision with vehicle in traffic (most harmful event)

### Vehicle 2 sequence of events

- 38 Struck by object/cargo/person from other vehicle
- 4 Cross centerline
- 3 Ran off road – left
- 41 Collision with bridge pier/support
- 38 or 41 Officer needs to determine (most harmful event for V2)

# APPENDIX J

## Air Bags Diagram

Source for images, tables, and charts shown in this appendix unless otherwise noted:  
*Model Minimum Uniform Crash Criteria, Fourth Edition.*

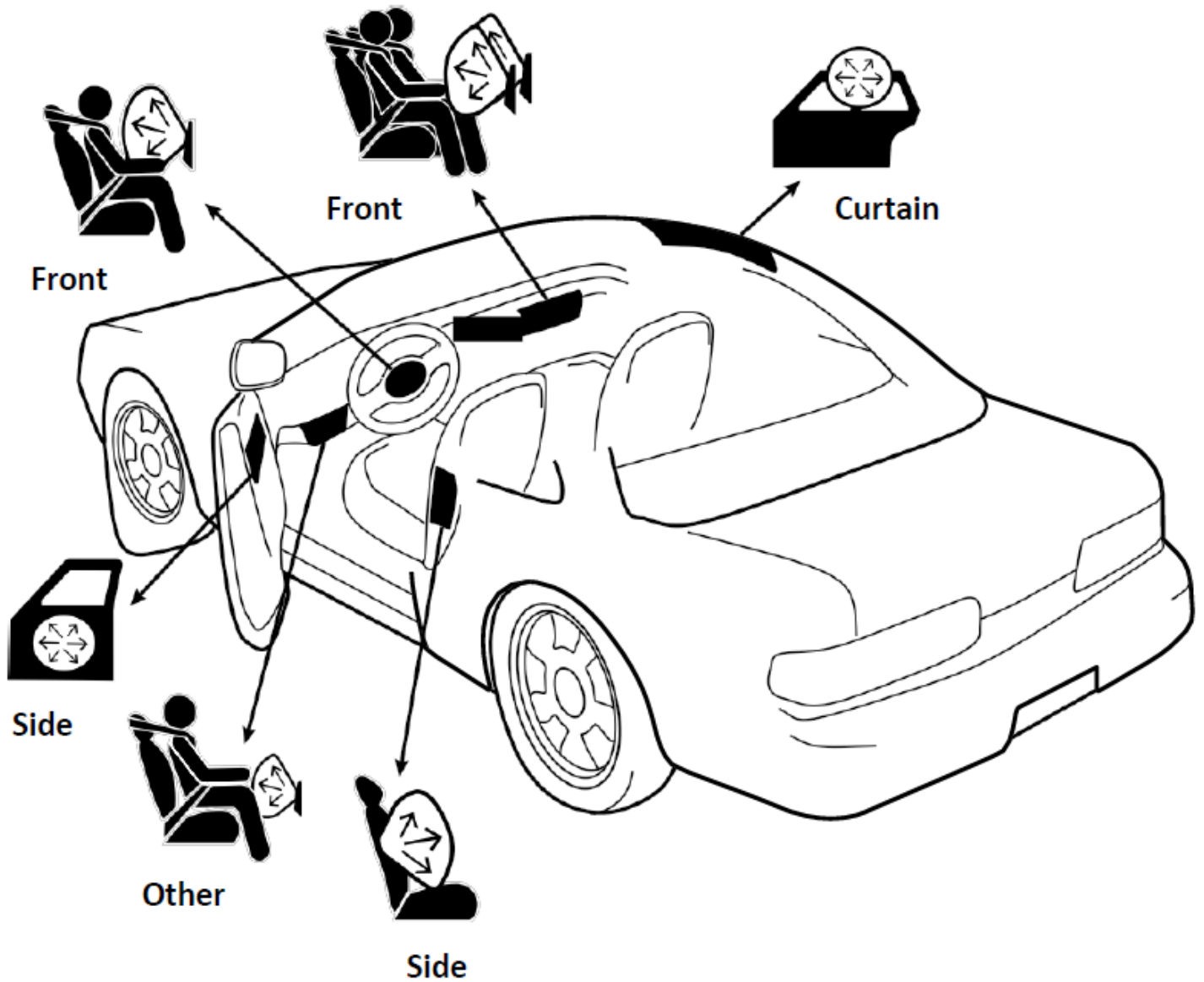

# APPENDIX K

## Clockpoint Diagrams for Different Types of Motor Vehicles

Source for images, tables, and charts shown in this appendix unless otherwise noted:  
*Model Minimum Uniform Crash Criteria, Fifth Edition.*

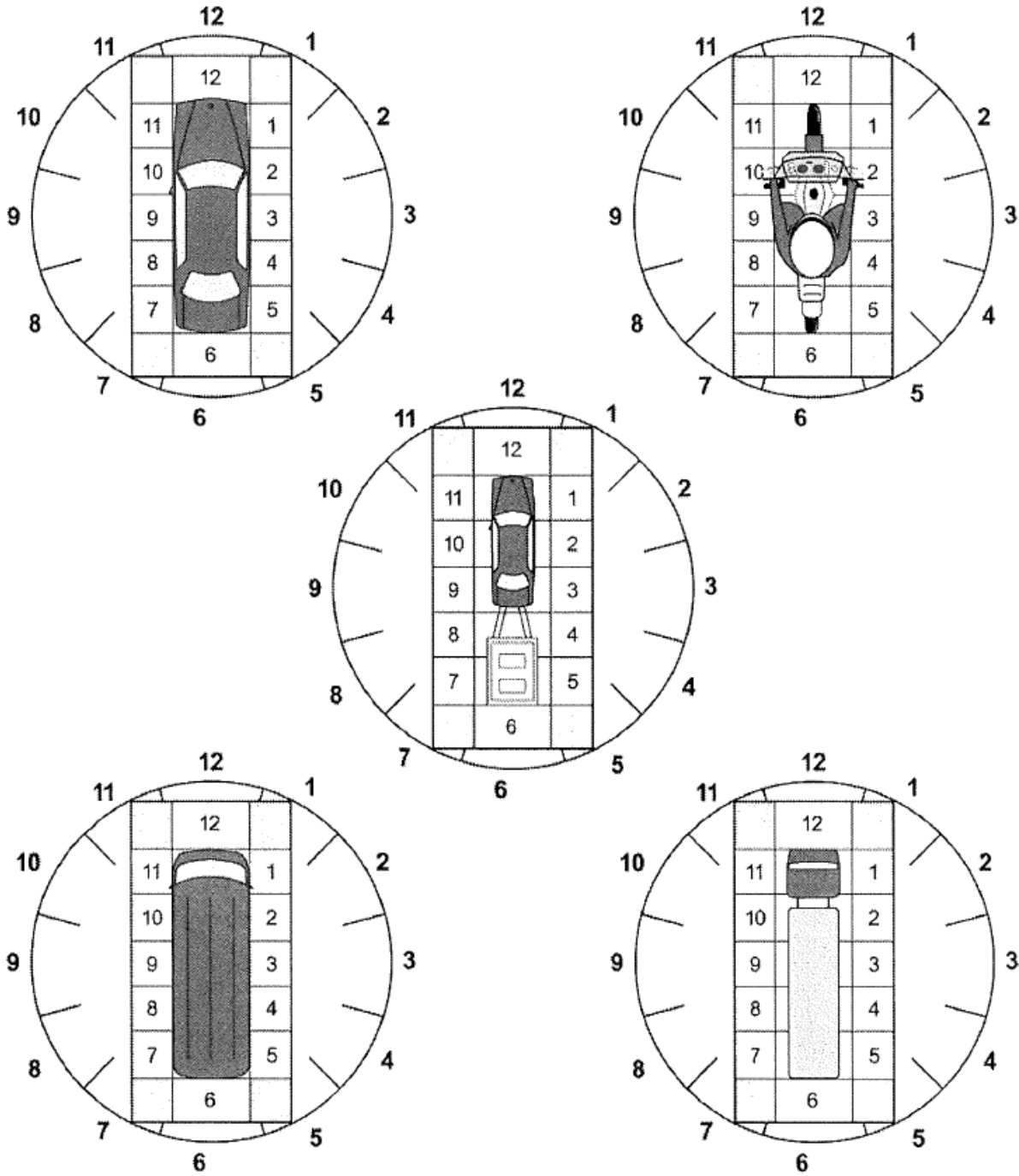

# APPENDIX L

## Diagram of an Interchange



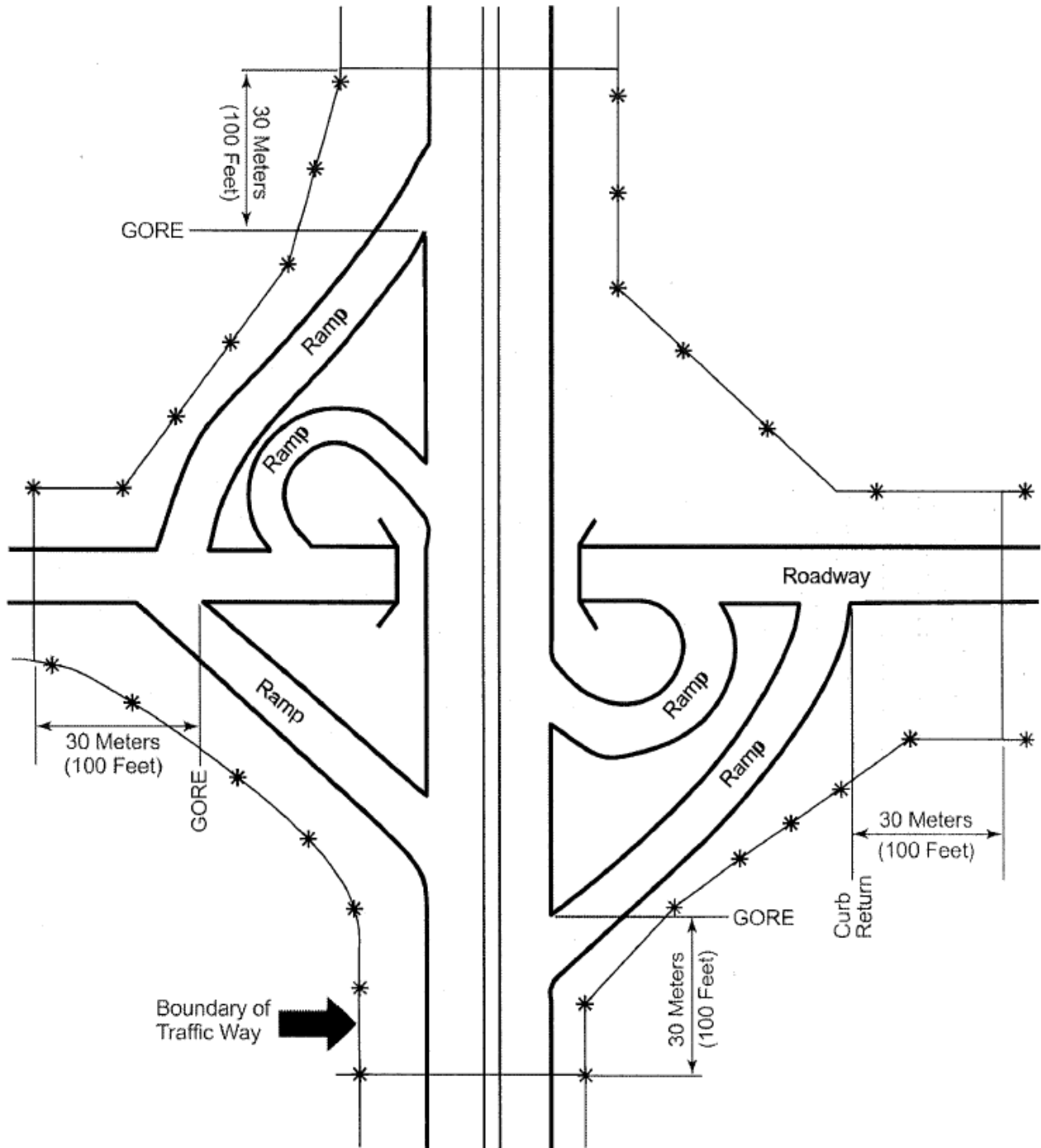





Source for images, tables, and charts shown in this appendix unless otherwise noted:  
*Model Minimum Uniform Crash Criteria, Fourth Edition.*



# APPENDIX M

## Commercial Motor Vehicle Information













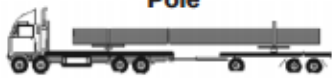

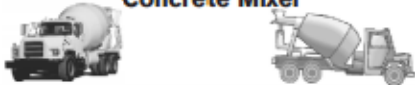
Source for images, tables, and charts shown in this appendix unless otherwise noted:  
 U.S. Department of Transportation's Federal Motor Carrier Safety Administration.

Vehicle Configuration	
<b>Bus (9-15 Seats, Including Driver)</b> 	<b>Truck/Trailer (Single-Unit Truck Pulling a Trailer)</b> 
<b>Bus (16 or More Seats, Including Driver)</b> 	<b>Truck Tractor (Bobtail)</b> 
<b>Single-Unit (2 Axles, 6 Tires)</b> 	<b>Tractor/Semi Trailer (One Trailer)</b> 
<b>Single-Unit (3 or More Axles)</b> 	<b>Truck Tractor/Double (Two Trailers)</b> 
	<b>Truck Tractor/Triple (Three Trailers)</b> 

Revised 06/05

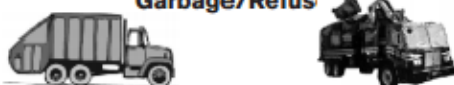
Federal Motor Carrier Safety Administration

U.S. Department of Transportation  
[www.fmcsa.dot.gov](http://www.fmcsa.dot.gov)

Cargo Body Type		
<b>Bus (9-15 Seats, Including Driver)</b> 	<b>Dump</b> 	<b>Pole</b> 
<b>Bus (16 or More Seats, Including Driver)</b> 	<b>Concrete Mixer</b> 	<b>Log</b> 
<b>Van/Enclosed Box</b> 	<b>Auto Transporter</b> 	<b>Intermodal Chassis</b> 
<b>Cargo Tank</b> 	<b>Garbage/Refus</b> 	<b>Vehicle Towing Motor Vehicle</b> 
<b>Flat Bed</b> 	<b>Sand, Chips, Gravel</b> 	<b>No Cargo Body</b> 

Federal Motor Carrier Safety Administration

U.S. Department of Transportation  
[www.fmcsa.dot.gov](http://www.fmcsa.dot.gov)



# Truck and Bus Crashes Reportable to FMCSA

## REPORT A TRAFFIC CRASH IF IT INVOLVES...

**Any truck** that has a gross vehicle weight rating (GVWR) of more than 10,000 pounds or a gross combination weight rating (GCWR) of more than 10,000 pounds used on public highways

**OR**

**Any motor vehicle** with seating to transport nine (9) or more people, including the driver's seat

**OR**

**Any motor vehicle** displaying a hazardous materials placard (regardless of weight)

## ...AND RESULTS IN

**A fatality:** any person(s) killed in or outside of any vehicle (truck, bus, car, etc.) involved in the crash or who dies within 30 days of the crash as a result of an injury sustained in the crash

**OR**

**An injury:** any person(s) injured as a result of the crash who immediately receives medical treatment away from the crash scene

**OR**

**A tow-away:** any motor vehicle (truck, bus, car, etc.) disabled as a result of the crash and transported away from the scene by a tow truck or other vehicle

Revised 06/05

Federal Motor Carrier  
Safety Administration



U.S. Department of Transportation  
[www.fmcsa.dot.gov](http://www.fmcsa.dot.gov)

**Crashes involving commercial motor vehicles and some non-commercial motor vehicles must be reported on a State's crash report and to the FMCSA. A commercial motor vehicle is any motor vehicle that is used on a trafficway for the transportation of goods, property, or people in interstate or intrastate commerce.**

### INCLUDED:

Here are some examples of commercial and non-commercial operations that, when involved in a crash, should be included if they meet the criteria on the front of this card.

#### Examples:

1. A trucking company or individual owner/operator hauling the goods of a business for a fee.
2. A manufacturing company hauling its own products to retail stores, or a retail store delivering products to its buyers.
3. A farm hauling its produce to market.
4. A motorcoach, airport shuttle, or hotel-owned shuttle bus or limousine service transporting passengers.
5. A government-owned truck or bus.
6. A school bus transporting students to/from school or school-related activities.
7. A rented or leased truck used to transport either commercial or personal goods.
8. A truck or truck tractor owned and operated for commerce being used for a personal trip or to transport personal goods.

### EXCLUDED:

Here are some examples of non-commercial operations that, when involved in a crash, should not be included.

#### Examples:

1. A non-commercial horse owner transporting hay bales from his pasture on one side of the road to his stables on the other side of the road in a truck with a GVWR greater than 10,000 pounds.
2. A homeowner carrying recyclables to a drop-off point in a personally owned pickup truck with a GVWR greater than 10,000 pounds.
3. A family of 10 persons taking a trip in the family's 12-person van.
4. A personally owned pickup truck hauling a boat, horse or utility trailer with a GCWR greater than 10,000 pounds not operating in commerce or as part of a business.
5. A family operating a personally owned and registered recreational vehicle or motor home.

## How to Find the Responsible Carrier and Correct U.S. DOT Number

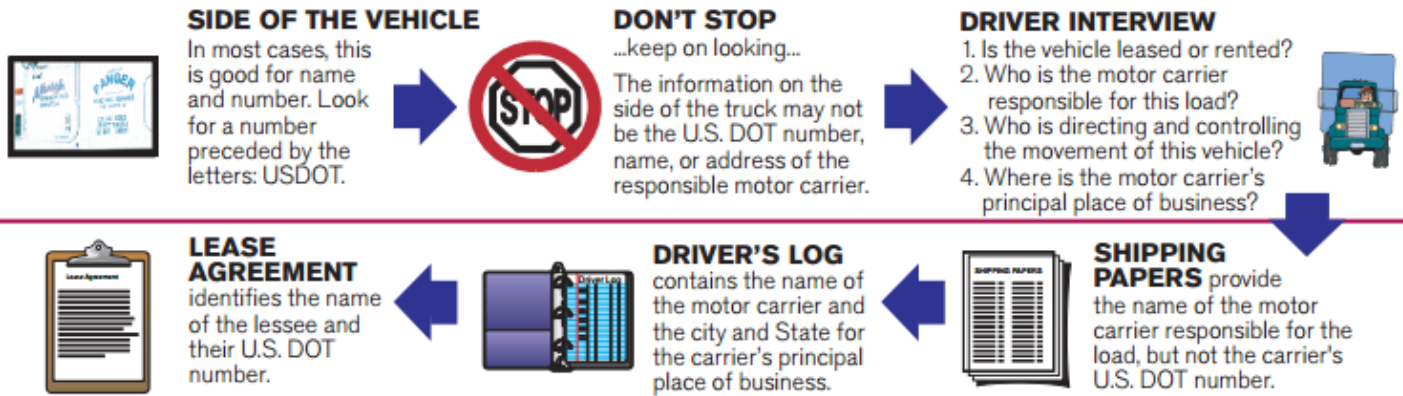

**NOTE: VEHICLE REGISTRATION**  
Generally good for identifying owner or registrant.  
CAREFUL: This may not be the responsible carrier!

**FMCSA WEB SITE:** <http://safer.fmcsa.dot.gov/CompanySnapshot.aspx> is an excellent source for verifying a motor carrier's U.S. DOT number, legal name, "doing business as" name, physical address, and phone number.

Revised 06/05

Federal Motor Carrier  
Safety Administration

U.S. Department of Transportation  
[www.fmcsa.dot.gov](http://www.fmcsa.dot.gov)

## How to Find the Responsible Carrier and Correct U.S. DOT Number

**EXAMPLE 1:** John Smith owns his own truck tractor, operating under John Smith Trucking. He contracts with White Manufacturing to take one of its trailers loaded with its goods from New York to Los Angeles.

**Who is the Motor Carrier:**  
A. John Smith?  
B. White Manufacturing?  
John Smith is the motor carrier, because he is the entity that has agreed to carry this particular load.

**EXAMPLE 2:** John Smith, driving his truck tractor, utilizes a cargo broker, K&S Trucking, to obtain goods from Intermodal Inc. shipping company for his return trip back to New York.

**Who is the Motor Carrier:**  
A. John Smith?  
B. K&S Trucking?  
C. Intermodal Inc.?  
John Smith is the motor carrier, because K&S transferred the responsibility of the load to John Smith.

**EXAMPLE 3:** John Smith, driving his truck tractor, leases his services to Polyester Chemical Company. Polyester directs Smith to deliver a semi-trailer from New York to St. Louis.

**Who is the Motor Carrier:**  
A. John Smith?  
B. Polyester?  
The lease agreement between Polyester and Mr. Smith makes Polyester the motor carrier responsible for the load.

**EXAMPLE 4:** John Smith is driving a tractor/semi-trailer owned and operated by ABC Trucking.

**Who is the Motor Carrier:**  
A. John Smith?  
B. ABC Trucking?  
ABC Trucking is the motor carrier. John Smith is just a driver for ABC Trucking.

**EXAMPLE 5:** John Smith is driving a tractor owned by ABC Trucking, which has been leased to XYZ Trucking. XYZ uses the tractor to pull XYZ trailers in its regular shipping service.

**Who is the Motor Carrier:**  
A. John Smith?  
B. ABC Trucking?  
C. XYZ Trucking?  
In this case XYZ is the motor carrier, because XYZ is directing the carrying of the load.

Federal Motor Carrier  
Safety Administration

U.S. Department of Transportation  
[www.fmcsa.dot.gov](http://www.fmcsa.dot.gov)

# Nine Classes of Hazardous Materials

**Class 1: Explosives**  
Divisions: 1.1, 1.2, 1.3, 1.4, 1.5, 1.6

**Class 6: Poison (Toxic) and Poison Inhalation Hazard**

**Class 2: Gases**  
Divisions: 2.1, 2.2, 2.3

**Class 7: Radioactive**

**Class 3: Flammable Liquid and Combustible Liquid**

**Class 8: Corrosive**

**Class 4: Flammable Solid, Spontaneously Combustible, and Dangerous When Wet**  
Divisions 4.1, 4.2, 4.3

**Class 9: Miscellaneous**

**Class 5: Oxidizer and Organic Peroxide**  
Divisions 5.1, 5.2

**Dangerous**

Revised 04/13

Federal Motor Carrier Safety Administration
U.S. Department of Transportation [www.fmcsa.dot.gov](http://www.fmcsa.dot.gov)

# Reporting Hazardous Materials Information

## ACCURATE REPORTING SAVES LIVES

Data you collect is used to calculate risk assessment, determine response methods, and develop regulations. Vehicles carrying hazardous materials are required to carry shipping papers containing the HM Class and ID number (or name). Your Accident or Collision Report/Supplement may ask the following hazardous materials questions (exact wording will vary by State):

<p><b>1. DOES THE VEHICLE HAVE A HAZARDOUS MATERIALS PLACARD?</b> YES <input type="radio"/> NO <input type="radio"/></p> <p>Placards should be on all four sides of the vehicle. For containers with bulk packages inside, if the required ID# marking is not visible, the transport vehicle must be marked on each side and each end.</p> <p style="text-align: center;"><b>Some Common Placards</b></p>	<p><b>2. ENTER THE FOUR-DIGIT NUMBER (OR NAME) FROM THE PLACARD</b> <u>1 9 9 3</u></p> <p>The four-digit number may be on an orange panel or a white "square-on-point" panel. If no four-digit number appears on the placard, enter the Placard Name.</p>
<p><b>3. ENTER THE HAZARDOUS MATERIALS CLASS NUMBER FROM THE BOTTOM OF THE PLACARD</b> <u>3</u></p> <p>The Class Number can be a one- or two-digit number with a decimal in the middle. <u>5.1</u></p> <p>It is critical for identifying and studying various types of hazardous materials involved in traffic crashes.</p>	<p><b>4. WAS HAZARDOUS CARGO RELEASED?</b> YES <input type="radio"/> NO <input type="radio"/></p> <p>The intent of this question is to determine whether any of the <b>placarded material</b> was released or escaped from its transport container into the environment. Fuel or oil carried by the vehicle for its own use is NOT considered cargo and should not be reported in this section.</p>

Federal Motor Carrier Safety Administration
U.S. Department of Transportation [www.fmcsa.dot.gov](http://www.fmcsa.dot.gov)



# APPENDIX N

## Sequence of Events

CODE	DESCRIPTION	HARMFUL Y/N
1	Ran off road, right	N
2	Ran off road, straight	N
3	Ran off road, left	N
4	Crossed centerline (undivided)	N
5	Crossed median (divided)	N
6	Evasive action (swerve, panic braking, avoidance)	N
7	Downhill runaway	N
8	Cargo/equipment loss or shift	Y
9	Equipment failure (tires, brakes, etc.)	N
10	Towed portion came apart (separation of units)	N
11	Loss of traction	N
12	Trailer fishtailing or swaying	N
13	Animal (avoided hitting)	N
20	Overturn/rollover	Y
21	Jackknife	Y
22	Non-contact vehicle (phantom vehicle avoidance)	N
23	Vehicle went airborne	N
24	Fell/jumped from vehicle	Y
30	Hit by thrown or falling object	Y
31	Collision with animal	Y
32	Collision with non-motorist	Y
33	Collision with vehicle in traffic/transport (moving)	Y
34	Vehicle re-entering roadway	N
35	Collision with parked motor vehicle	Y
36	Collision with work zone/maintenance equipment	Y
37	Collision with railway vehicle/train	Y
38	Struck by object/cargo/person from other vehicle	Y
40	Collision with bridge overhead structure	Y
41	Collision with bridge pier or support	Y
42	Collision with bridge rail or parapet	Y
43	Collision with curb/island/raised median causing damage	Y
44	Collision with ditch	Y
45	Collision with embankment	Y

	Harmful event
	Non-harmful event

CODE	DESCRIPTION	HARMFUL Y/N
46	Collision with ground	Y
47	Collision with culver/pipe opening	Y
48	Collision with guardrail - face	Y
49	Collision with guardrail - end	Y
50	Collision with concrete traffic barrier (median or right side)	Y
51	Collision with other traffic barrier (explain in narrative)	Y
52	Collision with cable barrier	Y
53	Collision with impact attenuator/crash cushion	Y
54	Collision with utility pole/light support	Y
55	Collision with traffic sign support	Y
56	Collision with traffic signal support	Y
57	Collision with other post/pole/support (explain in narrative)	Y
58	Collision with fire hydrant	Y
59	Collision with mailbox	Y
60	Collision with tree	Y
61	Collision with landscape/shrubbery	Y
62	Collision with snow bank	Y
63	Collision with fence	Y
64	Collision with wall	Y
65	Collision with building	Y
70	Vehicle on fire or explodes	Y
71	Immersion	Y
72	Leave the scene of crash (Hit & run)	N
73	Eluding law enforcement	N
74	Gas inhalation/asphyxiation	Y
75	Vehicle out of gear/rolled	N
94	Other pre-crash event (explain in narrative)	N
95	Other non-collision event (explain in narrative)	N
96	Collision with other non-fixed object (explain in narrative)	Y
97	Collision with other fixed object (explain in narrative)	Y
98	Other (explain in narrative)	N
99	Unknown (don't know all events due to vehicle left scene or it is unknown what was hit)	Y

	Harmful event
	Non-harmful event

# TEST YOUR CRASH KNOWLEDGE

## TRUE OR FALSE

---

1. A collision is considered legal intervention if a peace officer investigates.
2. A vehicle losing control on a roadway and coming to a rest in a parking lot is an example of a "Private property" crash.
3. If an officer investigates a two-car hit and run crash in which one vehicle immediately flees the scene, the officer should record both units on the crash report.
4. If I don't know how many people were in the fleeing vehicle, I should leave the "Total Occupants" field empty.
5. When a vehicle is abandoned at a crash scene, the "Total Occupants" field should be left blank.
6. A negative result on a driver's drug or alcohol test should be recorded on the crash report.
7. A traffic control device indicating an intersection (traffic signal, stop sign, yield sign, etc.) means the "Type of Roadway Junction/Feature" can be code 1 "No special feature."
8. A bicycle is considered a unit.
9. When a motor vehicle and train are involved in a crash, the train engineer should be entered in the driver's name field.
10. The "Cargo Body Type" of code 2 "Van/Enclosed box" is used when a "Vehicle's Configuration" is code 4 or code 5 "Van/Minivan or any buses" (vehicle configuration equals: 22, 23, 24, or 25).
11. A pickup truck (vehicle configuration is a code 2) can have a cargo body type of code 5 "Flatbed."
12. "Initial Travel Direction" refers to the direction of travel before the crash.
13. The VIN is important even if I have the vehicle's license plate number.
14. Using the location tool, I should locate a crash at the vehicle(s) final resting place.
15. A crash that occurs on private property does not need to be reported.
16. I should use an injury status of code 9 "Unknown" when I am not sure of the extent of injury.
17. When a pedestrian or bicyclist is involved, the "Manner of Crash/Collision" should be a code 1 "Noncollision."
18. The event sequence code 10 "Separation of units" is used when two vehicles collide and need to be pried apart.
19. Extent of damage code 4 "Disabling" is used when the cost of repair is greater than the value of the vehicle.
20. "Ran off road right" can be listed as the "First harmful event"



## ANSWERS TO TEST YOUR CRASH KNOWLEDGE

1. **False.** The “Legal Intervention” designation requires action to have been taken by law enforcement that forces a pursuit to come to an end. This includes the use of vehicle barricades, spike strips, a pursuit intervention technique (PIT) maneuver, or other methods of ending the chase. The crash, however, will not be recorded on the fleeing party because the crash was an intentional act.
2. **False.** Determining a crash’s location is based on where the incident begins, not where it ends.
3. **True.** Even if a vehicle involved in a crash is not at the scene upon investigation, it should still be recorded as a unit.
4. **False.** Unless a vehicle is parked or slipped out of gear causing a collision, there must be at least one occupant indicated. Even if the vehicle has left the scene, someone was driving it.
5. **False.** Someone drove the vehicle to the point where the situation became unstable that would indicate there was at least one occupant. The “Total Occupants” field should never be left blank, so if it’s clear a vehicle was driven to the crash scene, enter 1 in the “Total Occupants” field.
6. **True.** The Iowa DOT reviews cases that are marked as being under the influence in the “Driver Condition” field so it is helpful to know why there are no results given.
7. **False.** A traffic signal of some kind indicates there is an intersection or driveway present and should be marked accordingly.
8. **False.** A bicycle is self-propelled and therefore is a non-motorist and should be included in the “Non-motorist” section.
9. **False.** A train is not considered a motor vehicle so the engineer should not be indicated as a driver. However, a train is considered a unit, so do record the name of the railroad as the owner.
10. **False.** The “Van/Enclosed box” designation is used only for cargo-carrying vehicles, which excludes vans and buses.
11. **False.** A pickup may be pulling a code 12 “Boat” or a code 10 “Small utility trailer”, but not a code 5 “Flatbed,” as that is in reference to a semi.
12. **True.** If a vehicle is struck while executing a turn, the direction of travel is the direction before initiating the turn.
13. **True.** In the event a license plate is on a vehicle it’s not registered to be on, the VIN can help determine the vehicle has been correctly identified.
14. **False.** Location data needs to indicate where the unstable event started.
15. **False.** Iowa law does not distinguish where the crash occurs for it to be reportable, only if there is \$1,500 or more damage and/or injury and/or fatalities.
16. **False.** The use of code 9 for “Injury Status” is not helpful when trying to use data for various programs used for safety issues. Refer to [page 49](#) for an explanation of injury codes.
17. **True.** Pedestrians or bicyclists are considered non-motorists; the noncollision code is used when only one unit is involved in a crash.
18. **False.** “Separation of units” is used on events when a cargo body detaches from the vehicle pulling it (e.g., if a semitrailer separates from the tractor pulling it).
19. **False.** “Extent of Damage” of code 4 “Disabling” is damage that prevents departure of a motor vehicle from the scene of the crash in its usual manner in daylight after simple repairs.
20. **False.** “Ran off road right” is not a harmful event. A harmful event must cause damage or injury. Running off the road to the right can lead to a harmful event, but just running off the road is not a harmful event.

# INDEX

## A

Abbreviations .....	112
Alcohol test given.....	9
Angle, oncoming left turn, example.....	120
At intersection with .....	79

## B

Badge number .....	108
Broadside, example.....	120

## C

"Citation Charge" field.....	8
Citation information .....	8
"CMV" section .....	61
Code sheet.....	115
County numbers .....	114
County.....	2
Crash, reportable.....	1

## D

"Date of Report" field.....	109
"Date Reviewed" field .....	109
"Diagram" section .....	109
Diagram what happened.....	110
Disabling damage.....	34
"Divided Highway" section .....	80
"Driver" section .....	3
Driver's information .....	3
"Drug Test Given" field.....	9
Drug test information.....	10

## E

"Estimate of Damage" field, property.....	107
"Extent of Damage" field .....	34

## F

Functional damage .....	34
-------------------------	----

## G

General vicinity.....	79
-----------------------	----

## H

"Header" section.....	2
Head-on, example .....	82, 119

## I

Initial travel direction .....	18
Intended travel direction .....	18
Intersection definitions.....	87
Investigation made at scene?.....	109

## L

"Law Enforcement Case Number" field.....	2
--	---

## M

"Manner of Crash/Collision" field, examples .....	119
Minor damage.....	34
"Most Damaged Area" field.....	34
Motor vehicle crash data cycle .....	v

## N

"Name of Agency" field.....	109
"Narrative" section .....	110
Noncollision, example.....	119

## O

"Object Damaged" field.....	107
"Officer" section .....	108
"On Road, Street, or Highway" field .....	79
"Other Technical Investigating Agency" field .....	109

## P

"Point of Initial Impact" field .....	33
"Property Damage" section.....	107

**R**

Rear-end, example.....	120
"Report Given to all Drivers" field .....	109
"Report Reviewed By" field .....	109
Reportable crash.....	1
"Route" field .....	80

**S**

"Severe damage" field .....	34
Sideswipe, opposite direction, example .....	121
Sideswipe, same direction, example .....	121
"Signature of Officer" field .....	108
"Supplemental Information Will Follow" field .....	109

**T**

Technical investigation.....	109
"Test Results" field .....	9
"Time Officer Arrived" field .....	108
"Time Officer Notified" field .....	108

**U**

"Unit 1" and "unit 2" section .....	2
-------------------------------------	---

**V**

"Vehicle Action" field .....	18
------------------------------	----

**W**

"Witness"section.....	108
-----------------------	-----

**X**

X-coordinate .....	80
--------------------	----

**Y**

Y-coordinate .....	80
--------------------	----



---

IOWA DEPARTMENT OF TRANSPORTATION